

LOCATION: Grand Ave -- Elwood Ave
CITY/STATE: Oakland, CA

QC JOB #: 13350915
DATE: Thu, Apr 23 2015

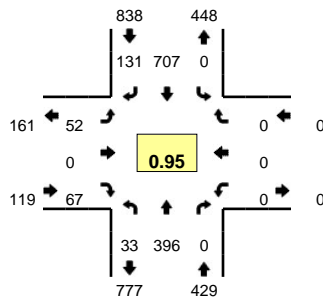

Peak-Hour: 7:55 AM -- 8:55 AM
Peak 15-Min: 8:20 AM -- 8:35 AM

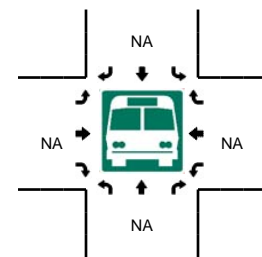
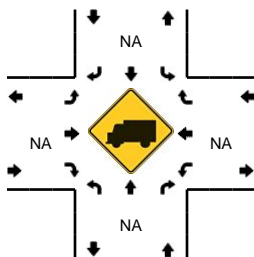
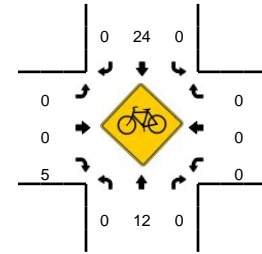
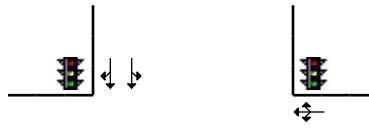
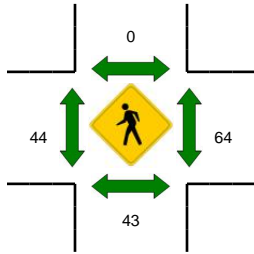
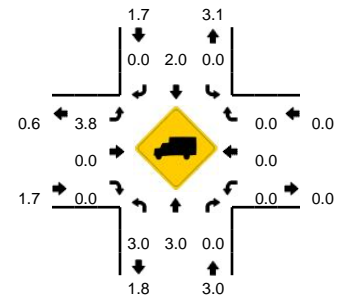

5-Min Count Period Beginning At	Grand Ave (Northbound)				Grand Ave (Southbound)				Elwood Ave (Eastbound)				Elwood Ave (Westbound)				Total	Hourly Totals	
	Left	Thru	Right	U	Left	Thru	Right	U	Left	Thru	Right	U	Left	Thru	Right	U			
7:00 AM	5	14	0	1	0	25	4	0	3	0	5	0	0	0	0	0	57		
7:05 AM	1	20	0	0	0	24	3	0	3	0	2	0	0	0	0	0	53		
7:10 AM	1	17	0	0	0	45	5	0	0	0	5	0	0	0	0	0	73		
7:15 AM	8	20	0	0	0	29	1	0	2	0	1	0	0	0	0	0	61		
7:20 AM	2	28	0	0	0	34	1	0	1	0	3	0	0	0	0	0	69		
7:25 AM	1	24	0	0	0	31	5	0	4	0	8	0	0	0	0	0	73		
7:30 AM	1	21	0	0	0	42	2	0	0	0	6	0	0	0	0	0	72		
7:35 AM	1	28	0	0	0	50	1	0	2	0	5	0	0	0	0	0	87		
7:40 AM	3	28	0	1	0	45	7	0	2	0	1	0	0	0	0	0	87		
7:45 AM	1	35	0	0	0	45	1	0	5	0	2	0	0	0	0	0	89		
7:50 AM	3	28	0	0	0	56	5	0	2	0	6	0	0	0	0	0	100		
7:55 AM	5	36	0	0	0	49	11	0	4	0	5	0	0	0	0	0	110	931	
8:00 AM	2	26	0	0	0	59	9	0	7	0	6	0	0	0	0	0	109	983	
8:05 AM	1	27	0	0	0	46	10	0	4	0	2	0	0	0	0	0	90	1020	
8:10 AM	2	29	0	0	0	63	9	0	4	0	8	0	0	0	0	0	115	1062	
8:15 AM	2	31	0	0	0	58	13	0	3	0	4	0	0	0	0	0	111	1112	
8:20 AM	3	35	0	1	0	56	17	0	3	0	10	0	0	0	0	0	125	1168	
8:25 AM	1	39	0	0	0	62	11	0	2	0	5	0	0	0	0	0	120	1215	
8:30 AM	2	32	0	1	0	60	11	0	7	0	8	0	0	0	0	0	121	1264	
8:35 AM	1	32	0	0	0	77	11	0	2	0	0	0	0	0	0	0	123	1300	
8:40 AM	3	37	0	0	0	58	9	0	4	0	4	0	0	0	0	0	115	1328	
8:45 AM	4	34	0	1	0	60	12	0	5	0	8	0	0	0	0	0	124	1363	
8:50 AM	4	38	0	0	0	59	8	0	7	0	7	0	0	0	0	0	123	1386	
8:55 AM	3	30	0	0	0	58	7	0	1	0	5	0	0	0	0	0	104	1380	
Peak 15-Min Flowrates	Northbound				Southbound				Eastbound				Westbound				Total		
	Left	Thru	Right	U	Left	Thru	Right	U	Left	Thru	Right	U	Left	Thru	Right	U			
All Vehicles	24	424	0	8	0	712	156	0	48	0	92	0	0	0	0	0	1464		
Heavy Trucks	0	8	0	0	0	8	0	0	0	0	0	0	0	0	0	0	16		
Pedestrians		56				0				44				44			144		
Bicycles	0	3	0		0	3	0		0	0	1		0	0	0		7		
Railroad																			
Stopped Buses																			

Comments: