



# TRANSPORTATION SYSTEM PLAN

## VOLUME 2: TECHNICAL APPENDICES



August 2020



Volume II – Appendix A  
**Technical Memorandum #1**

# MEMORANDUM #1

**Date:** December 18, 2018  
**To:** Rick Zylstra (City of Oakridge)  
 Louis Gomez (City of Oakridge)  
 David Helton (Oregon Department of Transportation)

Project #: 22477

**From:** Darci Rudzinski and Kyra Haggart, Angelo Planning Group

**Project:** City of Oakridge Transportation System Plan Update

**Subject:** Memorandum #1: Background Information Summary

This memorandum presents a review of existing plans, regulations, and policies that affect transportation planning in the City of Oakridge. The review explains the relationship between the documents and planning within the City's Urban Growth Boundary (UGB), identifying key issues that will guide the Transportation System Plan (TSP) update process. This memorandum is intended to guide later decisions regarding selection of preferred transportation solutions and necessary amendments to related plan documents and regulations.

Some documents included in this review establish transportation-related standards, targets, and guidelines with which the TSP update must be coordinate and consistent with; others contain transportation improvements that will need to be factored into the future demand modeling and otherwise reflected in the draft TSP update. Local policy and regulatory requirements described in this review—such as the Oakridge Development Code (WDO)—may be subject to recommended amendments in order to implement the recommendations of the updated TSP. This memorandum helps set the state for those potential amendments, which will be prepared as part of project implementation (Tasks 6 and 7).

The following goals and plans were reviewed.

<b>STATE TRANSPORTATION PLANNING FRAMEWORK.....</b>	<b>2</b>
OTP Goal 1, Mobility and Accessibility.....	3
OTP Goal 2, Management of the System .....	4
OTP Goal 3, Economic Vitality.....	4
OTP Goal 4, Sustainability.....	5
OTP Goal 5, Safety and security .....	6
<b>LOCAL AND REGIONAL PLANS .....</b>	<b>6</b>
Lane County Transportation System Plan (2017) .....	6
Oregon Highway 58 Refinement Plan (2006) .....	8
City of Oakridge Transportation System Plan (2001) .....	8
Oakridge Comprehensive Plan (1981) .....	9
Oakridge Code and Land Use Ordinance.....	9
Oakridge Pedestrian Safety Study (2016).....	10
Oakridge-Westfir Community Trails Plan (2008).....	11
Oakridge Parks Master Plan (2011).....	12
Oakridge Area Wayfinding Plan (2013).....	12

## Key Findings

- ▶ Significant updates to the Oregon Bicycle and Pedestrian Plan were adopted in 2016 and the Oakridge TSP update can benefit from new state policy.
- ▶ The Transportation Planning Rule has been updated since the last Oakridge TSP update.
- ▶ There are a number of local plans that have been adopted subsequent to the 2001 TSP, including the Oakridge Pedestrian Safety Study and the Parks Master Plan. For adopted plans that are not currently reflected in the TSP, policies, standards, and recommendations that have an impact on the transportation system will be considered for consistency as part of this TSP update.

## STATE TRANSPORTATION PLANNING FRAMEWORK

In 1973, Governor Tom McCall signed Senate Bill 100 into law, creating the framework for land use planning in Oregon. Senate Bill 100 established Statewide Planning Goals, including Goal 12 Transportation, which defines the State's goal for transportation: "To provide and encourage a safe, convenient and economic transportation system." Senate Bill 100 also requires local jurisdictions to develop comprehensive plans that must include a transportation element. Goal 12 states that a transportation plan shall:

1. consider all modes of transportation including mass transit, air, water, pipeline, rail, highway, bicycle and pedestrian;
2. be based upon an inventory of local, regional and state transportation needs;
3. consider the differences in social consequences that would result from utilizing differing combinations of transportation modes;
4. avoid principal reliance upon any one mode of transportation;
5. minimize adverse social, economic and environmental impacts and costs;
6. conserve energy;
7. meet the needs of the transportation disadvantaged by improving transportation services;
8. facilitate the flow of goods and services so as to strengthen the local and regional economy; and
9. conform with local and regional comprehensive land use plans.

A Transportation System Plan (TSP) must be consistent with other local policies, including policies related to housing, economic development, health, and environmental conditions. If a TSP is not consistent with other local policies, the TSP must include proposed plan amendments to address that conflict. Local jurisdictions are required to implement their TSP through adopted land use regulations, which is typically done by adoption of development regulations to ensure consistency with the updated facility standards and policy objectives in the TSP. Local comprehensive plans must also be consistent with Statewide Planning Goals, statewide plans, and regional plans. For the Oakridge TSP, key statewide and regional plans that must be considered for consistency include the following:

- ▶ Oregon Transportation Plan
- ▶ Oregon Highway Plan
- ▶ Oregon Bicycle and Pedestrian Plan
- ▶ Oregon Public Transportation Plan
- ▶ Oregon Freight Plan
- ▶ Oregon State Rail Plan
- ▶ Oregon Transportation Safety Action Plan

- ▶ Oregon Transportation Options Plan
- ▶ Oregon Aviation Plan

As the guiding document for the State of Oregon, the Oregon Transportation Plan (OTP) establishes goals, policies, strategies and initiatives that address the core challenges and opportunities facing transportation in Oregon. Goals and policies in the OTP are further implemented by various modal plans, including the Aviation System Plan, Bicycle and Pedestrian Plan, Freight Plan, Highway Plan, Public Transportation Plan, Rail Plan and the Transportation Safety Action Plan.

Each of the OTP's seven goals is defined by more specific policies and strategies. Key OTP goals and policies for consideration during development of the Oakridge TSP include the following:

---

## OTP GOAL 1, MOBILITY AND ACCESSIBILITY

---

**OTP Goal 1, Mobility and Accessibility**, aims to enhance Oregon's quality of life and economic vitality by providing a balanced, efficient, cost-effective and integrated multimodal transportation system that ensures appropriate access to all areas of the state, the nation and the world, with connectivity among modes and places.

**Policy 1.1: Development of an Integrated Multimodal System.** It is the policy of the State of Oregon to plan and develop a balanced, integrated transportation system with modal choices for the movement of people and goods.

**Strategy 1.1.1:** Plan and develop a multimodal transportation system that increases the efficient movement of people and goods for commerce and production of goods and services that is coordinated with regional and local plans.

**Strategy 1.1.2:** Promote the growth of intercity bus, truck, rail, air, pipeline and marine services to link all areas of the state with national and international transportation facilities and services. Increase the frequency of intercity services to provide travel options.

**Strategy 1.1.4:** In developing transportation plans to respond to transportation needs, use the most cost-effective modes and solutions over the long term, considering changing conditions and based on the following:

- Managing the existing transportation system effectively.
- Improving the efficiency and operational capacity of existing transportation infrastructure and facilities by making minor improvements to the existing system.
- Adding capacity to the existing transportation system.
- Adding new facilities to the transportation system.

**Policy 1.2: Equity, Efficiency and Travel Choices.** It is the policy of the State of Oregon to promote a transportation system with multiple travel choices that are easy to use, reliable, cost-effective and accessible to all potential users, including the transportation disadvantaged.

**Strategy 1.2.1:** Develop and promote inter and intra-city public transportation.

**Strategy 1.2.2:** Better integrate, locate, and design passenger and freight multimodal transportation facilities and connections to expedite travel and provide travel options. Locate and design transportation facilities to connect with other modes.

**Implications for the Oakridge TSP:** The TSP will need to plan for all modes of transportation available in Oakridge to promote mobility options and provide equitable transportation services to all potential users including the transportation

disadvantaged. The Oakridge TSP will promote the most cost-effective modes and solutions over the long term.

---

## OTP GOAL 2, MANAGEMENT OF THE SYSTEM

---

**OTP Goal 2, Management of the System**, aims to improve the efficiency of the transportation system by optimizing the existing transportation infrastructure capacity with improved operations and management.

**Policy 2.1: Capacity and Operational Efficiency.** It is the policy of the State of Oregon to manage the transportation system to improve its capacity and operational efficiency for the long term benefit of people and goods movement.

**Strategy 2.1.2:** Protect the integrity of statewide transportation corridors and facilities from encroachment by such means as managing access to state highways, limiting interchanges, creating safe rail crossings and controlling incompatible land use around airports, ports, pipelines and other intermodal passenger and freight facilities.

**Strategy 2.1.3:** Use advanced traveler information devices, incident management, speed management, improvements to signaling systems and other technologies to extend the efficiency, safety and capacity of transportation systems. Develop protocols and implement methods for alternate routing to respond to incidents.

**Strategy 2.1.4:** Enhance efficiency and reduce conflicts among transportation users, for example by reducing bottlenecks and geometric constraints, and improving or removing modal crossings. Provide for a network of arterials and highways to efficiently move goods and services while enhancing safety and community movements on local streets. Provide for signal prioritization and road patterns that support public transit. Support rail reconfiguration and additional tracks that benefit passenger and freight movements.

**Implications for the Oakridge TSP:** The TSP will prioritize strategies to better manage existing facilities over costly major roadway capacity improvements.

---

## OTP GOAL 3, ECONOMIC VITALITY

---

**OTP Goal 3, Economic Vitality**, promotes the expansion and diversification of Oregon's economy through the efficient and effective movement of people, goods, services and information in a safe, energy-efficient and environmentally sound manner.

**Policy 3.2 – Moving People to Support Economic Vitality.** It is the policy of the State of Oregon to develop an integrated system of transportation facilities, services and information so that intrastate, interstate and international travelers can travel easily for business and recreation.

**Strategy 3.2.2:** In regional and local transportation system plans, support options for traveling to employment, services and businesses. These include, but are not limited to, driving, walking, bicycling, ridesharing, public transportation and rail.

**Strategy 3.2.4:** Address scenic values in state, regional and local planning, improvements and maintenance. Support state and federal Scenic Byways and Tour Routes and connections to parks and recreation areas.

**Strategy 3.2.5:** Promote tourism via air, bicycles, motor vehicles, rail and ships. Support connections to recreational trails.

**Policy 3.3 – Downtowns and Economic Development.** It is the policy of the State of Oregon to provide transportation improvements to support downtowns and to coordinate transportation and economic development strategies.

**Strategy 3.3.1:** Coordinate private and public resources to provide transportation improvements and services to help stimulate active and vital downtowns, economic centers and main streets.

**Implications for the Oakridge TSP:** The TSP will identify projects that support existing and planned economic centers including downtown Oakridge and the City's Industrial Park. The Oakridge TSP will also identify projects that support the West Cascades National Scenic Byway and links to other roads and trails in the vicinity of Oakridge to promote recreation and tourism.

---

## OTP GOAL 4, SUSTAINABILITY

---

**OTP Goal 4, Sustainability,** seeks to provide a transportation system that meets present needs without compromising the ability of future generations to meet their needs from the joint perspective of environmental, economic and community objectives. This system is consistent with, yet recognizes differences in, local and regional land use and economic development plans. It is efficient and offers choices among transportation modes. It distributes benefits and burdens fairly and is operated, maintained and improved to be sensitive to both the natural and built environments.

**Policy 4.3 – Creating Communities.** It is the policy of the State of Oregon to increase access to goods and services and promote health by encouraging development of compact communities and neighborhoods that integrate residential, commercial and employment land uses to help make shorter trips, transit, walking and bicycling feasible. Integrate features that support the use of transportation choices.

**Strategy 4.3.1:** Support the sustainable development of land with a mix of uses and a range of densities, land use intensities and transportation options in order to increase the efficiency of the transportation system. Support travel options that allow individuals to reduce vehicle use.

**Strategy 4.3.2:** Promote safe and convenient bicycling and walking networks in communities. Fill in missing gaps in sidewalk and bikeway networks, especially to important community destinations such as schools, shopping areas, parks, medical facilities and transit facilities. Enhance walking, bicycling and connections to public transit through appropriate community and main street design. Promote facility designs that encourage walking and biking.

**Strategy 4.3.4:** Promote transportation facility design, including context sensitive design, which fits the physical setting, serves and responds to the scenic, aesthetic, historic and environmental resources, and maintains safety and mobility.

**Strategy 4.3.5:** Reduce transportation barriers to daily activities for those who rely on walking, biking, rideshare, car-sharing and public transportation by providing: Access to public transportation and the knowledge of how to use it. Facility designs that consider the needs of the mobility-challenged including seniors, people with disabilities, children and non-English speaking populations.

**Implications for the Oakridge TSP:** The TSP will identify solutions that support walking, biking, and public transportation use, particularly to important community destinations. Transportation solutions in the Oakridge TSP will be environmentally responsible and improve the scenic and aesthetic characteristics of Oakridge while preserving or improving safety and mobility for all users.

---

## OTP GOAL 5, SAFETY AND SECURITY

---

**OTP Goal 5, Safety and Security**, aims to plan, build, operate and maintain the transportation system so that it is safe and secure.

**Policy 5.1 – Safety.** It is the policy of the State of Oregon to continually improve the safety and security of all modes and transportation facilities for system users including operators, passengers, pedestrians, recipients of goods and services, and property owners.

**Strategy 5.1.3:** Ensure that safety and security issues are addressed in planning, design, construction, operation and maintenance of new and existing transportation systems, facilities and assets.

**Policy 5.2 – Security.** It is the policy of the State of Oregon to provide transportation security consistent with the leadership of federal, state and local homeland security entities.

**Strategy 5.2.3:** Improve the evacuation and emergency response capabilities of the urban and rural transportation system.

**Implications for the Oakridge TSP:** The TSP will identify projects that ensure the transportation system maintains and improves individual safety and security and that also maximizes public safety and service access.

---

## LOCAL AND REGIONAL PLANS

---

### LANE COUNTY TRANSPORTATION SYSTEM PLAN (2017)

---

The Lane County Transportation System Plan (TSP), adopted in September 2017, defines a shared vision and strategy for investing in the regional transportation system over the next 20 years. It is the County's long-range plan for developing and managing its transportation system outside UGBs to provide mobility and accessibility to essential employment, goods, and services and to support rural land uses and resource lands. The 2017 TSP replaces the prior TSP adopted in 2004. It is adopted as part of the Lane County Rural Comprehensive Plan and complies with applicable transportation and planning requirements.

The TSP is intended to serve as a 20-year policy and investment guide and it addresses major roadways (arterials and collectors, but not local roads). The TSP does not include ongoing operations and maintenance activities, although the Tool Box section highlights several best practices and techniques.<sup>1</sup> The TSP is multi-modal—addressing the needs of many modes, such as cars, trucks, buses, motorcycles, farm equipment, bicycles, and people walking

---

<sup>1</sup> See Chapter 6 Standards for the Toolbox, which is intended to provide “guidance to the County on various multimodal tools that could be implemented as needs arise and when funding is available.”



or using wheelchairs—and it includes a policy and project directing Lane County to develop a Bicycle and Pedestrian Master Plan with a Safe Routes to Schools emphasis to look more closely at needed bicycle and walking connections and networks.

Chapter 2 of the TSP includes 2035 population forecasts generated by PSU for smaller cities surrounding the Eugene/Springfield UGB, including Oakridge, which were used by County staff to project future traffic volumes for the year 2036 for County roadways.

Chapter 5 of the Lane County TSP includes an investment plan to meet the transportation needs of Lane County transportation system over the next 20 years and includes a list of recommended projects to address those needs. Several of the projects in TSP Table 5-3, the Illustrative Project List (i.e. projects that are not reasonably likely to be funded by 2036 based on current financial constraints), are within the City of Oakridge, list the City as an agency partner, and/or are located directly adjacent to the City UGB. These projects are summarized in Table 1.

**Table 1. Lane County TSP Projects Involving Oakridge**

Project Number	Figure #	Project Name	Project Description	Agency Partners	Project Cost
45	5-15	Fish Hatchery Road from OR 58 to 1st Street	Widen shoulders for safety	Lane County / City of Oakridge	\$500,000
67	5-15	High Prairie Road from 1st Street to Oakridge UGB	Construct to major collector standards and implement intersection improvements.	Lane County	\$875,000
92	5-15	Kitson Springs Road from OR 58 to Hill Creek Bridge	Construct to major collector standards with two 11' travel lanes and 6' shoulders on both sides. Integrate systemic safety measures.	Lane County	\$48,000,000
151	5-13,5-15	West Boundary Road from Lowell UGB to end of pavement	Construct to minor collector standards and implement safety measures such as rumble strips, guardrails, and removing obstacles from the clear zone.	Lane County / City of Lowell / City of Oakridge / Forest Service	\$24,150,000

Projects in the West Fir/Oakridge area are mapped on Fig. 5-15, Deficiencies and Improvements Subarea 11.

The TSP notes that OR 58, which runs through Oakridge, is designated by ODOT as a Tier 1 lifeline route in Lane County. Routes identified as Tier 1 are the most critical to ensuring a functioning statewide transportation network. A functioning Tier 1 lifeline system provides traffic flow through the state and to each region.<sup>2</sup>

**Project Relevance:** County transportation improvement projects will be reviewed and considered in the Oakridge TSP update. Recommendations in the updated TSP will need to be consistent with the County TSP; if necessary, needed refinements to the County plan will be identified and discussed as part of this update process.

<sup>2</sup> See Chapter 6 Standards, Emergency Routes, p. 58.

---

## OREGON HIGHWAY 58 REFINEMENT PLAN (2006)

---

The Oakridge Highway 58 Refinement Plan, adopted in January 2006, addresses questions about how Highway 58 should look and function through the City of Oakridge. Highway 58 bisects the city, and although the historic downtown is located to the north of the highway, much of the newer commercial development has located along the corridor. Due to the increased development, Highway 58 has increasingly served pedestrians and bicyclists as well as motor vehicles, and the City identified a need for bike lanes, a continuous sidewalk system, and convenient and safe pedestrian crossings as a primary focus in the plan.

The plan includes three planning alternatives (Baseline Improvements Alternative, Crestview Business District Alternative, and Highway 58 Business District Alternative) that reflect a combination of policy and design elements based on input from the PAC and comments and observations made at the public open house. The alternatives share common elements with regard to sidewalks, bike lanes, and access management recommendations, but differ in terms of lane configuration.

The plan recommendations include a hybrid preferred alternative, recommended amendments to the City's Zoning Code, access management strategies, funding options for recommended improvements, and strategies for implementation. The hybrid design concept recommends maintaining the existing five-lane cross section on the Westside of the study area with a transition of the highway from five lanes to three lanes consistent with the current transition from five lanes to four lanes between Jones Street and the Salmon Creek Bridge. The Implementation Strategies section states that upon adoption the Refinement Plan will be incorporated into the City's adopted Transportation System Plan. Land use recommendations for implementing the Refinement Plan anticipated updating the City's Zoning Code.

**Project Relevance:** The TSP update process will consider the recommendations identified in the Highway 58 Refinement Plan and incorporate and update the concepts, strategies, and implementation measures into the updated TSP where applicable and appropriate.

---

## CITY OF OAKRIDGE TRANSPORTATION SYSTEM PLAN (2001)

---

The Oakridge TSP guides the management and development of appropriate transportation facilities in the City of Oakridge and ensuring consistency with state, regional, and local plans. The current plan was adopted in December of 2001. It contains transportation goals, policies, and standards to address the City's transportation needs. The TSP provides a plan for the development of the transportation system, which addresses improvements to roadways, new pedestrian and bicycle facilities, improvements in public transit service, and transportation demand management strategies.

**Project Relevance:** The TSP update process will review goals, policies, standards, and proposed projects from the adopted plan and will determine what to retain or change in the updated TSP. This process will update transportation improvement projects for all modes based on current and projected needs. Updated data, stakeholder and community involvement, and evaluation criteria will be used in making these determinations. Updated goals and policies will guide the project (see Technical Memorandum #2).

---

## OAKRIDGE COMPREHENSIVE PLAN (1981)

---

The Oakridge Comprehensive Plan serves as the principal policy document for land use within the Oakridge Urban Growth Boundary and guides physical development of the City. Volume I of the plan was originally adopted in 1977, and the currently-adopted Volume IV was adopted in 1981 and was most recently amended in 1993. The Comprehensive Plan contains goals, objectives, policies, and implementation programs and policies, and is adopted by reference as Chapter 154 of the Oakridge Development Code. The goals and policies contained in the adopted TSP were adopted and became part of the Oakridge Comprehensive Plan in 2001. The TSP goals and policies replaced transportation-related goals and policies in the Comprehensive Plan; the rest of the TSP was incorporated into the Comprehensive Plan as a Transportation Element and replaced transportation-related background information in the Comprehensive Plan.<sup>3</sup>

Other areas of the Comprehensive Plan that are applicable to this TSP update include:

- ▶ The **Commerce** goal, which encourages a full range of quality retail and service commercial functions to adequately serve the City and its sub-regional service area, and addresses highway strip-commercial development, access, and off-street parking.
- ▶ The **Energy Conservation** goal, which is intended to facilitate energy conservation through a community development strategy that addresses government programs, individual conservation efforts, and educational programs.
- ▶ The **Implementation** goal, which is intended to maintain a sound program of local citizen involvement and intergovernmental coordination in support of plan adoption, implementation, and future revision and/or updating.

**Project Relevance:** The TSP update process will consider the City's adopted goals, policies, and recommendations, to the extent they are still applicable and desired by the community. In addition to updated transportation goals and policies, implementation of the TSP may prompt other policy-level changes in areas related to transportation, including economic development, housing, and inter-governmental coordination. The TSP may also suggest policy-neutral changes to the organization of portions of the comprehensive plan to improve clarity and ease of use.

---

## OAKRIDGE CODE AND LAND USE ORDINANCE

---

The City of Oakridge regulates transportation primarily through Chapter 151 (Subdivisions) of Title XV (Land Usage) of the City's charter. Chapter 151 regulates tentative plans, final plat procedures, land partitions, design standards, and improvement requirements for subdivisions. Section 151.081 of Chapter 151 includes regulations specifically related to the transportation and street design, with some provisions for access management and circulation also found in Sections 151.082 (Blocks) and 151.083 (Building Sites and Lots). Title XV (Land Usage) includes the City's Zoning Ordinance (Chapter 153, Articles 1 through 34) and Comprehensive Plan (Chapter 154).

Supplementary District Regulations in the Zoning Ordinance include development requirements related to off-street vehicular and bicycle parking (Article 20), access management (Article 21), and multi-modal circulation and connectivity (Article 25, Section 25.06 Criteria for Site Plan Review Evaluation). The Old Town Design Subdistrict (Section 15.06) includes vehicular and pedestrian access requirements. Requirements in Section 15.05, Airport Safety Subdistrict, are intended to "prevent air space obstructions in airport approaches and surrounding areas

---

<sup>3</sup> See Chapter 1, Section D. Planning Process, in the adopted City of Oakridge Transportation System Plan.

through height restrictions and other land use controls as deemed essential to protect the health, safety and welfare of the people of the City of Oakridge and Lane County.”

**Project Relevance:** The updated TSP will be implemented incrementally through development regulated by the Oakridge Code and Land Use Ordinance. It is therefore important that the code’s provisions be consistent with the goals and policies of the updated TSP; its specific recommendations regarding roadway functional classifications, design, access management, and multi-modal connectivity; and the provisions of the Transportation Planning Rule (TPR). The code review in this memorandum is a first step in the process of evaluating how the Oakridge Code and Land Use Ordinance addresses common transportation planning priorities and aligns with state rules and regulations. The Implementation phase o the TSP update will include a more in-depth review of adopted development requirements and will propose modifications intended to both implement the updated TSP and bring the City’s code into closer compliance with the State Transportation Planning Rule.

## OAKRIDGE PEDESTRIAN SAFETY STUDY (2016)

The Oakridge Pedestrian Safety Study, completed in February 2016, is intended to improve safety for all modes of travel along the OR 58 corridor in Oakridge, with the primary emphasis to provide safe pedestrian and bicycle crossing locations along the highway. The study, which consisted of both a public involvement component and a technical analysis component, resulted in a toolbox of pedestrian crossing treatments and a compilation of recommended safety projects along OR 58 to improve pedestrian and bicycle safety (Chapter 3, Crossing Treatment Toolbox). Crossing improvement concepts were developed for the following five locations along OR 58 and are summarized in Table 2.

Rank	Crossing Locations	Priority
1	Rock Road to Jones Road	Short-term
2	West of River Road	Short-term
3	Rainbow Road	Mid-term <sup>a</sup>
4	Hills Street	Mid-term
5	Union Street	Mid-term
A <sup>b</sup>	East of Jones Road	TBD <sup>c</sup>

<sup>a</sup> Lighting improvements only at Rainbow Road

<sup>b</sup> Crossing location added based on public input

<sup>c</sup> Crossing location will be a short-term priority with construction of pedestrian bridge/community center

The study states that for the priority location ranked first the recommended improvement treatments include Rectangular Rapid Flashing Beacons (RRFB), sidewalk infill, and supplemental street lighting. It also documents that ODOT and the City are currently working on a design for an enhanced pedestrian crossing at this location. In addition, a secondary crossing location with RRFBs is recommended east of Jones Road based on the City’s future plans to construct a community center and pedestrian bridge near this location. As a second priority project, the study recommends that a raised median, curb extension, or other traffic calming improvement should be made along with sidewalk in fill along the south side of OR 58. Similar recommendations are made for the third and fourth priority locations with the addition of improved street lighting.<sup>4</sup> A prioritized project list and cost estimates for each

<sup>4</sup> See the Executive Summary, Recommended Projects, in the Pedestrian Safety Study.

of the crossing improvement locations and signalized improvement locations can be found in Chapter 6, Project Implementation.

Corridor-wide safety treatments—including street lighting, speed feedback signs, and lane conversions—were also considered along the entire length of the study area. No specific locations were identified for access management, with the exception of the pedestrian crossing improvement locations. However, the study presents an option for a three-lane roadway conversion on OR 58 to increase corridor safety and in response to the surrounding land uses, available roadway width, collision analysis, and motor vehicle volumes. This alternative, including the need to obtain approval for any reductions in capacity on a freight route, is discussed in detail in Chapter 5 OR 58 Lane Conversion Alternative.

**Project Relevance:** The updated TSP update will consider improvements to the non-motorized transportation systems within Oakridge, including addressing areas where pedestrian safety should be enhanced. Pedestrian crossing treatments and corridor-wide safety treatments recommended in the Pedestrian Safety Study will be considered in addressing needed pedestrian improvements. The recommended safety projects, crossing locations, and signalized improvement locations should be revised, where necessary, and incorporated into the project list developed through the TSP update process.

---

## OAKRIDGE-WESTFIR COMMUNITY TRAILS PLAN (2008)

---

The Oakridge-Westfir Community Trails Plan, completed in 2008, is intended to improve connectivity and increase the range of opportunities for residents and visitors to enjoy non-motorized means of recreation and transportation in the greater Oakridge-Westfir area. The plan envisions a trail network that connects the communities of Oakridge and Westfir and surrounding areas through a system of regional parks and open spaces in the Willamette National Forest. The plan's goals seek to benefit all citizens of the Oakridge-Westfir area and to make the area a regional destination for outdoor recreation and attract new resident industries and jobs.

The Oakridge-Westfir Community Trails Plan compliments other local and statewide planning efforts, including the Oregon Statewide Comprehensive Outdoor Recreation Plan published in 2003 (SCORP). It is a non-regulatory, conceptual plan and, at the time of the plan's completion, none of the proposed ideas have been approved for funding. The plan notes that the implementation of those ideas will be contingent upon attracting outside funding sources such as grants and donations, motivating local volunteers, and building stakeholder consensus. The plan also notes that it should be incorporated into future revisions of the City of Oakridge Comprehensive Plan.

The plan includes a comprehensive inventory of trails and trailheads in the Oakridge-Westfir plan area, including trail facilities located in the cities of Oakridge and Westfir and those in the surrounding Willamette National Forest. The Oakridge-Westfir Community Trails Plan also includes a chapter on implementation, which discusses the steps and considerations necessary to implement the goals and recommendations of the plan. Appendix C of the plan includes the detailed inventory of trail facilities, proposed facilities, and facilities that are in need of major improvements.

**Project Relevance:** The TSP update process will consider the recommended projects and improvements identified in the Oakridge-Westfir Community Trails Plan as part of the City's pedestrian transportation system.

---

## OAKRIDGE PARKS MASTER PLAN (2011)

---

The City of Oakridge Parks Master Plan, adopted in March 2011, is a long-term vision and plan of action for the City's park system. It is intended to guide development of the municipal parks system for the 20-year period between 2010 and 2030. The plan encapsulates the community's aspirations for the park system through a series of goals and objectives and identifies strategies and techniques for operation and development of parks and funding and is intended to improve the quality of its parks to meet the needs of current and future residents and enhance economic development.

The Parks Master Plan provides an inventory of existing parks and an analysis of appropriate park classifications and standards; identifies current and future park needs using technical data and community input; creates a strategy for prioritizing and implementing park improvements; provides a capital improvement program (CIP) that enables the City to achieve its goals; and identifies potential funding techniques and sources to implement the CIP. The plan does not contain site planning in individual parks.

**Project Relevance:** The TSP update process will consider the Master Plan's goals, policies, and identified needs and improvements when updating the non-motorized elements of the transportation system. The TSP update will address multi-modal access to parks and trails facilities and needed projects to complete and enhance bicycle and pedestrian transportation systems.

---

## OAKRIDGE AREA WAYFINDING PLAN (2013)

---

The Oakridge Area Wayfinding Plan, adopted in March 2013, creates a visitor wayfinding signage plan for the towns of Oakridge and Westfir that includes conceptual illustrations for a uniform sign system, preliminary sign locations and probable costs for sign fabrication and installation. The wayfinding plan is part of a larger economic development initiative through Travel Oregon's Rural Tourism Studio program to attract visitors to the area through recreation-based tourism.

The plan's objectives include creating a unified wayfinding system to connect visitors with Oakridge and Westfir amenities, river access and the surrounding National Forest trail system; directing travelers off Highway 58 to explore Oakridge's commercial districts, attractions and parks; connecting the towns of Oakridge and Westfir with designated bike routes; connecting Oakridge's commercial districts and parks with designated hiking and bicycling trails; enhancing trail and community information at key locations within commercial districts, city parks and National Forest trailheads; providing destination identity signage for Oakridge/Westfir, commercial districts and parks that establish a sense of place; and integrating the wayfinding plan with marketing initiatives for brochures, maps and digital media.

The plan identifies design guidelines based on the area's historical character and includes a set of sign types including identity signs, directional signs, informational kiosks, and trail signs. It includes very preliminary locations for wayfinding signs for future planning purposes, as well as preliminary costs and recommended procurement strategies.

**Project Relevance:** The TSP update process should consider the preliminary recommendations in the Oakridge Area Wayfinding Plan to ensure that transportation solutions and preferred projects do not preclude wayfinding signage envisioned in the document.



Volume II – Appendix B  
**Technical Memorandum #2**

## MEMORANDUM #2

**Date:** December 18, 2018

Project #: 22477

**To:** Rick Zylstra (City of Oakridge)  
Louis Gomez (City of Oakridge)  
David Helton (Oregon Department of Transportation)

**From:** Ashleigh Ludwig, PE, Marc Butorac, PE and Jacki Gulczynski (Kittelison & Associates, Inc.)  
Darci Rudzinski, AICP, Angelo Planning Group

**Project:** City of Oakridge Transportation System Plan Update

**Subject:** Memo #2: Goals and Policies

---

## MEMORANDUM OVERVIEW

---

This memorandum documents the guiding principles, goals, and policies for the City of Oakridge Transportation System Plan (TSP) update. The goals and policies will guide the TSP update process to ensure key issues are addressed within this process. The goals and policies presented in this memorandum are based on the currently adopted (2001) TSP goals and policies and current transportation issues.

This document is organized into two sections:

- ▶ **Background** – This section provides an overview of the goals and policies from the 2001 TSP and summarizes key transportation issues and changes in Oakridge since the adoption of the 2001 TSP.
- ▶ **Goals and Policies** – This section covers the desired project outcomes and transportation needs that support the land use and growth vision for Oakridge. Plan goals for the Updated TSP were developed based on the prior TSP and changes in Oakridge since the adoption of the 2001 TSP. Policies outline the discrete elements that, taken as a whole, support and promote the goals.



## 01 | BACKGROUND

Transportation System Plans provide the City and ODOT with guidance for planning, operating, funding, and improving the multimodal transportation system within the City of Oakridge Urban Growth Boundary. The TSP focuses on priority projects, policies, programs, pilot projects, and studies for the next 20 years but also provides a vision for additional projects that could be implemented should funding become available. The plan is intended to be flexible to respond to changing community needs and revenue sources over the next 20 years. Finally, the TSP builds consensus among the City, Lane County, and ODOT on the transportation needs and priority projects for the community, allowing the local citizens to inform projects that are carried forward for funding from state and federal agencies.

The goals from the 2001 City of Oakridge TSP are summarized below.

- ▶ *Goal 1 – Economic Development: Provide for a transportation system that enhances development of the region's economy.*
- ▶ *Goal 2 – Transportation System Characteristics: Provide for a transportation system that emphasizes safety, convenience, efficiency, and livability.*
- ▶ *Goal 3 – Mobility for All: Provide a transportation system with facilities and services that meet mobility needs of all potential users.*
- ▶ *Goal 4 – Transportation and Land Use Planning: Integrate transportation and land use planning to maximize the benefits of transportation.*
- ▶ *Goal 5 – Plan Implementation: Develop the community's transportation system through implementation of the transportation system plan.*

Since the development of the City's 2001 TSP, the community has changed substantially, and many of the goals and projects in the 2001 TSP have been accomplished. The population of the City has increased by 14 percent since 2000, and approximately 100 new homes have been built. After experiencing the loss of several businesses and an economic downturn related to the decline of the timber industry, the City now has an industrial park with several tenants, a dozen new businesses in the Uptown District, and has become a major tourist and outdoor recreational center. Oakridge is surrounded by National Forest land with an extensive network of roads and trails for hiking and mountain biking.

Highway 58 and the Union Pacific Railroad provide important regional and statewide freight connections that pass through and bisect the City of Oakridge. Highway 58 is designated as a Statewide Highway in the Oregon Highway Plan (OHP) and is an important multimodal freight corridor, providing a connection between Central Oregon and the Willamette Valley. The Union Pacific Railroad I-5 Corridor runs through the City and maintains an active switch yard in Oakridge. The highway and railroad corridors create barriers to north-south travel within the City, particularly for pedestrians and bicyclists.

The updated TSP will address a variety of current transportation-related issues in Oakridge, including:

- ▶ The need for improved facilities for pedestrians and bicyclists, including facilities needed to provide safe routes to schools.
- ▶ The incorporation of planning studies completed since 2001.
- ▶ The need to support economic development by identifying adequate freight access to the City's Industrial Park, multi-modal connections through the Uptown District, and connections to the area's trail network.
- ▶ The need for improved regional and local transit service to service residents.
- ▶ The City's desire to open an Oakridge Amtrak station.

## 02 | GUIDING PRINCIPLE AND PLAN GOALS AND POLICIES

The overall guiding principle of the plan is to provide and encourage a safe, convenient, and economical transportation system. The following plan goals follow the framework of the 2001 TSP while also including updates to support the land use and growth vision for the City of Oakridge. The goals for desired project outcomes are listed below and identified in the following sections.

- ▶ Economic Development
- ▶ Transportation System Characteristics
- ▶ Mobility for All
- ▶ Transportation and Land Use Planning
- ▶ Plan Implementation
- ▶ Safety

---

### GOAL 1 – ECONOMIC DEVELOPMENT

---

Plan a transportation system that supports existing industry and encourages economic development in the City.

#### POLICIES

- a. Ensure adequate access to services on OR 58.
- b. Provide for efficient freight mobility on OR 58 while balancing the access and mobility for residents and visitors.
- c. Encourage rail freight service by designating land along the tracks to allow uses that depend on freight, attracting industry that relies on freight and minimizing the adverse impacts of rail freight within the urban area.
- d. Support improvements to the airport and preservation of adjacent land for air-compatibility uses to promote increased use of the airport for air freight and passenger services.
- e. Improve city gateways, entrances, OR 58, and other key roadways and multimodal facilities with aesthetic improvements that also provide utilitarian value, such as street trees, landscaping, and lighting.
- f. Support strategies and actions that strive to improve the region's air quality such as prioritizing improvements to the multi-modal transportation system.
- g. Encourage tourism by promoting and upgrading bicycle and pedestrian recreational routes, services, amenities, and wayfinding.
- h. Support recreational use of national forest lands by improving connections between the City and forest lands.

---

## GOAL 2 – TRANSPORTATION SYSTEM CHARACTERISTICS

---

Provide a transportation system that balances transportation services for the safety, convenience, efficiency, and livability of all users.

### POLICIES

- a. Apply roadway functional classifications and street design standards that meet residents, travelers, and emergency service needs for mobility and access, are sensitive to topography and scenic views, and minimize impacts to natural features.
- b. Support completion of street connections that create a grid-style layout to provide system redundancy and require new streets to be connected to the existing street system.
- c. Apply access management standards, balancing the need for mobility with the need for direct and convenient access to major activity centers.
- d. Use the street system and its infrastructure, where appropriate, to convey and treat stormwater runoff.
- e. Support improvements to the roadways giving priority to projects that improve safety and connectivity, alleviate traffic congestion and are financially feasible.
- f. Identify improvements to complete a bikeway system for circulation within Oakridge and connections to routes and paths outside Oakridge.
- g. Maintain and improve a pedestrian walkway system for circulation within Oakridge and connections to paths outside Oakridge.
- h. Support improvement of OR 58 in Oakridge with facilities for bicyclists and pedestrians.
- i. Consider the potential to establish or maintain bikeways or walkways prior to vacating any public easement or right-of-way.
- j. Require bicycle parking facilities as part of new multi-family residential developments of four or more units; new retail, office, and institutional developments; and all transit transfer stations and Park-and-Ride lots.
- k. Operate and maintain roads, bikeways and pedestrian ways at a level that catches up on the back log of maintenance needs and reduces the need for more expensive future repair.
- l. Provide transportation mode choices to all users of the transportation system.
- m. Consider impacts to low income or minority populations when assessing the impacts of transportation infrastructure projects.
- n. Reduce reliance on the state highway system for making local trips.
- o. Provide a network of arterials, collectors, and local streets that are interconnected, appropriately spaced, and reasonably direct in accordance with City and State design and connectivity standards.
- p. Preserve and maintain the existing transportation system in a state of good repair.

- q. Work with the City of Oakridge, Lane County, and the Oregon Department of Transportation to develop, operate, and maintain intelligent transportation systems and technological solutions that reduce travel delay and improve system efficiency and reliability.

---

## GOAL 3 – MOBILITY FOR ALL

---

Provide a transportation system with facilities and services that meet mobility needs of all potential users.

### POLICIES

- a. Support the provision of public transportation facilities, services, and programs within the community and the Eugene-Springfield area, and support efforts to provide inter-city bus and passenger rail service to the community.
- b. Promote alternative modes, transit and dial-a-ride service, and rideshare/carpool programs through community awareness and education.
- c. Support the development of regional public transit, including identifying park-and-ride opportunities.
- d. Promote an interconnected network of bicycle, pedestrian, and transit facilities throughout the City.
- e. Develop a Safe Routes to School (SRTS) plan to prioritize improvements to encourage walking and biking to schools.
- f. Consider bicycle and pedestrian facility needs during construction of new roads and during upgrades of existing roads.
- g. Promote a transportation system that includes pedestrian and bicycle connections to recreational and tourist destinations throughout the City.
- h. Support widening shoulders for bicycle travel as part of roadway preservation and improvement projects or as separate stand-alone projects.
- i. Provide safe, convenient and direct pedestrian and bicycle facilities and routes to promote health and the physical and social well-being of City of Oakridge residents, to reduce vehicular traffic congestion, to provide transportation and recreational alternatives, and to support multi-modal access to health-supportive goods and services.
- j. Plan for a multi-modal system that limits users' exposure to pollution and that enhances air quality.
- k. Adopt a standard for mobility to help maintain a minimum level of freight and/or motor vehicle travel efficiency and by which land use amendments and development proposals can be evaluated.
- l. Apply State, County, and/or City mobility standards to facilities under their respective jurisdiction.
- m. Provide connections for all modes that meet applicable City and Americans with Disabilities Act (ADA) standards.

- n. Provide a transportation system that provides equitable multimodal access for underserved and vulnerable populations to schools, parks, employers, health and social services, and other essential destinations, including those that require trips to Eugene or other areas.
- o. Expand public transportation opportunities to support both commuting and tourism needs.

---

## GOAL 4 – TRANSPORTATION AND LAND USE PLANNING

---

Integrate transportation and land use planning to maximize the benefits of transportation.

### POLICIES

- a. Require adequate vehicle and bicycle parking for new development. Allow on-street parking or other nearby sites to be used to satisfy parking requirements.
- b. Coordinate with Lane County regarding needed transportation improvements on County roadways within the City, as well as improvements needed to serve uses outside the UGB on land that is designated for development by the Lane County Rural Comprehensive Plan, or that may be brought into the UGB in the future.
- c. Develop a land use plan that supports transportation goals and policies for OR 58. Coordinate with the Oregon Department of Transportation to implement system management and operations strategies on Highway 58.
- d. Consider the impacts of land use decisions on existing or planned transportation facilities and apply appropriate land use regulations to protect the function of existing or planned roadways.
- e. Protect existing right-of-way and setbacks and require dedication of additional right-of-way or easements at the time of land development or land division to obtain adequate street widths, bikeways, and walkways, and to accommodate transit facilities.
- f. Consider emerging technology and plan for a flexible system that can adapt to changing transportation needs.
- g. Identify the 20-year roadway system needs to accommodate developing or undeveloped areas.

---

## GOAL 5 – PLAN IMPLEMENTATION

---

Develop the community's transportation system through implementation of the transportation system plan.

### POLICIES

- a. Comply with federal, state, and local policies and regulations related to transportation and land use.
- b. Establish a coordinated approach to the development, operation, and maintenance of jointly managed transportation facilities. Coordinate with Lane County and Westfir to establish a coordinated approach.

- c. Conduct effective public involvement programs that create opportunities for citizens, businesses, regional and local governments, and state agencies to comment on proposed policies, plans, programs, and improvement projects.
- d. Identify and maintain stable and diverse revenue sources.
- e. Leverage federal and state highway funding programs.
- f. Identify areas where refinement plans or interim measures would increase the life of a facility or delay the need for improvements.

---

## GOAL 6 – SAFETY

---

Provide a transportation system that promotes the safety of current and future travel modes for all users.

### POLICIES

- a. Develop a multi-modal transportation system that incorporates safety and operational improvements for bicyclists and pedestrians.
- b. Ensure that roadways are designed, constructed, and maintained to an appropriate standard for their expected use, vehicle speeds, and vehicle traffic.
- c. Identify safe rail crossing locations for multi-modal users.
- d. Promote safety improvements for pedestrian and bicycle facilities at and near school zones.
- e. Reduce incidence and severity of crashes.
- f. Provide a transportation system that allows for adequate emergency vehicle access to all land uses.
- g. Promote railway and highway safety at and near railway intersections.
- h. Evaluate opportunities for Intelligent Transportation Systems (ITS) to address traffic safety by providing real-time information to drivers and to enhance transportation efficiency for all modes.



Volume II – Appendix C  
**Technical Memorandum #3**

# MEMORANDUM #3

**Date:** December 18, 2018  
**To:** Rick Zylstra (City of Oakridge)  
 Louis Gomez (City of Oakridge)  
 David Helton (Oregon Department of Transportation)

Project #: 22477

**From:** Ashleigh Ludwig, PE, Marc Butorac, PE and Jacki Gulczynski (Kittelson & Associates, Inc.)

**Project:** City of Oakridge Transportation System Plan Update

**Subject:** Memorandum #3: Funding for Transportation System Improvements

This memorandum documents current, historical, and potential future funding sources for implementation for the City of Oakridge Transportation System Plan (TSP) update. The funding information provides context for evaluating projects and defining priorities that will allow the City to utilize available funding opportunities and maximize current resources to preserve and improve current infrastructure and support future capital improvements and programs.

## 01 | HISTORICAL FUNDING

### CITY STREET FUND OVERVIEW

The current transportation funding sources for the City Street Fund were provided by the City and are summarized in Table 1. This table shows the most recent five years of revenues and expenditures. Additional information about revenue and expenditures is described below.

**Table 1. Transportation Revenue and Expenditures (2013-2018)**

Revenue/Expenditure Source	FY 2013-2014	FY 2014-2015	FY 2015-2016	FY 2016-2017	FY 2017-2018
<b>Revenue</b>					
<i>Beginning Balance</i>	\$456,806	\$322,347	\$278,006	\$80,673	\$95,400
State Gas Tax	\$184,549	\$184,300	\$176,135	\$194,900	\$206,742
Fuel Dealers License Fee	\$47,977	\$54,149	\$ 69,842	\$62,046	\$54,774
Intergovernmental	\$32,892	\$5,428	\$ 57,427	\$3,245	\$2,970
Miscellaneous	\$2,388	\$468	\$3,386	\$3,054	\$9,438
Other Financing Sources	\$1,624	\$5,268	\$2,454	\$12,242	\$9,087
<b>Total Revenue (Excluding Beginning Balance)</b>	<b>\$269,429</b>	<b>\$249,612</b>	<b>\$309,243</b>	<b>\$275,487</b>	<b>\$283,011</b>
<b>Expenditures</b>					
Personal Services	\$71,742	\$50,166	\$51,922	\$53,113	\$75,723
Materials & Services	\$222,814	\$233,748	\$246,452	\$205,648	\$ 207,096
New Equipment - Capital	\$6,548	-	-	-	-
Street Improvements	\$100,784	\$8,039	\$206,202	-	-
Fund Transfers	\$2,000	\$2,000	\$2,000	\$2,000	\$2,000
<b>Total Expenditures</b>	<b>\$403,888</b>	<b>\$293,953</b>	<b>\$506,576</b>	<b>\$260,761</b>	<b>\$284,820</b>



## REVENUE

As shown in Table 1, the average yearly revenue for the City Street Fund is approximately \$275,000. This revenue is funded by both state and local sources. The primary funding source for the Street Fund is the State Gas Tax (approximately 68 percent of all revenue). The beginning balance line item identifies how much money was in the Street Fund at the beginning of each fiscal year. As shown, a large surplus was available in 2014. While the revenue from the gas tax is generally increasing each year, the total revenue has remained relatively constant over the five-year period.

## EXPENDITURES

The City's expenditures can vary substantially from year to year depending on whether the City completes any capital improvement projects that year. The largest consistent expense that the City encounters is the materials and services category. These expenses average approximately \$225,000 per year and cover the general maintenance of the City's street system.

The City has completed two street improvement projects between 2013 and 2018. The Garden Road Improvement project was completed in 2013 for a cost of approximately \$100,000, and the Teller Road Improvements project was completed in 2015 for a cost of approximately \$200,000. These projects are reflected in the "Street Improvement" line item in Table 1. Street improvements and capital projects are not annual occurrences; these occur on an as-needed basis when funding is available.

Excluding the street improvement projects, the City spends approximately \$285,000 per year from the Street Fund.

## SUMMARY

Table 2 provides a comparison of the revenue and expenditures and resulting net income of the Street Fund for 2013 through 2018. The table includes the average annual net income both with and without street improvement projects.

Since 2013, the City has incurred approximately a \$10,000 deficit each year simply to maintain existing roadways. This is shown by the average annual net income (excluding street improvements). When considering the funding the City applied towards street improvement projects, the City spent an average of \$72,000 per year more than the Street Fund achieved in revenue each year. Therefore, the City was able to complete the street improvement projects largely using funds that were saved from years prior to 2013.

**Table 2. City Street Fund Net Income (2013-2018)**

Description	FY 2013-2014	FY 2014-2015	FY 2015-2016	FY 2016-2017	FY 2017-2018
Net Income: Revenue minus Expenses	\$(134,459)	\$(44,341)	\$(197,332)	\$14,726	\$(1,890)
Average Annual Net Income					\$(72,643)
Net Income (Excluding Street Improvements): Revenue minus Expenses	\$(33,675)	\$(36,302)	\$8,869	\$14,726	\$(1,890)
Average Annual Net Income (Excluding Street Improvements)					<b>\$(9,638)</b>

This funding gap indicates that the City needs to identify new funding sources to continue operating and maintaining its transportation facilities. If the spending trend were to continue without additional funding sources, the City Street Fund would last less than ten years. Oakridge has relied upon its reserve funds to continue operating but needs to identify additional long-term reliable funding to remain sustainable. In addition to identifying funding sources for operations and maintenance, the City also lacks available funding to complete Citywide improvement projects. A new funding source is necessary to establish a reliable, sustainable reserve.

## OREGON DEPARTMENT OF TRANSPORTATION FUNDING

Table 3 identifies a list of Oregon Department of Transportation (ODOT) funded projects in Oakridge including the cost and a breakdown percentage funded from federal, state, and local funds for each project. ODOT has not provided direct funding to Oakridge transportation improvements since 2013. The City received Congestion Mitigation and Air Quality (CMAQ) funding annually until 2013 but has not received CMAQ funding since then.

Table 3. ODOT Funded Projects in Oakridge					
Project Key Number	Project Name	Total Project Cost	Federal Funds	State Funds	Local Funds
<b>STIP Projects Prior to 2005</b>					
10781	Dexter Park-Kitson Ridge Road	\$8.96M	87%	13%	0%
06890	Willamette Highway & Greenwater Park	\$384k	77%	23%	0%
05813	Oakridge Rest Area	\$145k	0%	4%	96%
05222	Crestview – Salmon Creek	\$32k	0%	100%	0%
03284	Salmon Creek Bridge	\$2.33M	82%	18%	0%
<b>CMAQ Funding</b>					
17972	CMAQ – 2012	\$65k	90%	0%	10%
16976	CMAQ – 2013	\$65k	90%	0%	10%

Several ODOT projects in Oakridge and the surrounding area are identified in the 2018-2021 STIP. These projects and their anticipated budgets are:

- ▶ CMAQ Funding – 2019, \$65,000
- ▶ Oakridge-Westfir Ride Center – 2019, \$165,932
- ▶ Lane Transit District (LTD) Ridesource Preventive Maintenance – 2018, \$321,985
- ▶ LTD Ridesource Preventive Maintenance – 2019, \$348,815
- ▶ Diamond Express Vehicle Replacement (LTD) – 2019, \$330,000
- ▶ LTD accessible services - Oakridge Diamond express operations – 2018, \$275,822
- ▶ LTD accessible services - Oakridge Diamond express operations – 2019, \$275,824
- ▶ OR 58 Passing Lanes (MP 31.6-32.4) – 2021, \$720,000

More information is available at: [https://www.oregon.gov/ODOT/STIP/Documents/OnlineSTIP\\_Public.pdf](https://www.oregon.gov/ODOT/STIP/Documents/OnlineSTIP_Public.pdf)

## TRANSIT FUNDING

The Lane County Transit District (LTD) provides the Diamond Express route, which offers daily intercity service between Eugene and Oakridge four times per day, seven days per week. This service is funded through local, state and federal sources. The Diamond Express route requires approximately \$133,000/annually to maintain service. State and Federal funds account for approximately 80 percent of the revenue needed to operate the route. The remaining cost is covered by rider fares and the City of Oakridge. According to the Diamond Express website, the City of Oakridge contributed approximately \$11,000 to the transit system in the 2010 – 2011 fiscal year.

More information about the Diamond Express route is available at: <https://www.ltd.org/diamondex-frequently-asked-questions/>

---

## CURRENT FUNDING SUMMARY

---

Based on the current local, state, and transit funding sources, the following conclusions were made:

- ▶ The City needs approximately \$10,000 in additional revenue per year to continue maintain existing roads. This does not include opportunities to fund capital improvements.
- ▶ The City needs to identify new funding sources to complete any future transportation improvement projects.
- ▶ ODOT has not funded a transportation project in the City since those completed prior to 2005.
- ▶ Assuming the City's contribution to the transit system has remained relatively constant since 2010, the City spends nearly \$11,000 on the existing transit system each year.

Additional funding sources are critical to improving the transportation system in Oakridge. Without funding, the City will deplete the Street Fund in approximately 10 years. The following section highlights current funding sources and funding opportunities at the federal, state, and local level.

## 02 | CURRENT AND POTENTIAL FUNDING SOURCES

This section describes current and potential federal, state, and local funding sources the City could pursue to fund transportation improvement projects. These sources will be considered during the development of the TSP.

---

### FEDERAL SOURCES

---

#### FIXING AMERICA'S SURFACE TRANSPORTATION (FAST) ACT

Fixing America's Surface Transportation (FAST) Act funds surface transportation programs, including, but not limited to, federal-aid highways. The FAST Act is the first long-term surface transportation authorization enacted in a decade that provides long-term funding certainty for surface transportation. Non-motorized transportation projects, as a mode of surface transportation, are eligible for funding through the FAST Act. The FAST Act improves mobility on highways by establishing and funding new programs to support critical transportation projects to ease congestion and facilitate the movement of freight on the interstate system and other major roads. The FAST Act authorizes \$226.3 billion in federal funding for FY 2016 through 2020 for road, bridge, bicycling, and walking improvements.

More information is available at: <https://www.fhwa.dot.gov/fastact/summary.cfm>

#### SURFACE TRANSPORTATION BLOCK GRANT (STBG)

In 2015, the FAST Act amended the Surface Transportation Program (STP) and changed the program name to the Surface Transportation Block Grant Program (STBG). STBG funds are flexible funding sources for jurisdictions and are eligible to be used for non-motorized transportation projects. STBG funds are contract authority. STBG funds are available for obligation for a period of three years after the last day of the fiscal year for which the funds are authorized. Therefore, funds are available for obligation for up to four years. The federal share is generally 80 percent and 90 percent for projects on the Interstate System unless the project adds lanes that are not high-occupancy-vehicle or auxiliary lanes. For projects that add single occupancy vehicle capacity, that portion of the project will revert to 80 percent. Safety improvements may have a Federal share of 100 percent.

More information is available at: <https://www.fhwa.dot.gov/specialfunding/stp/160307.cfm#c>

## CONGESTION MITIGATION AND AIR QUALITY (CMAQ)

The Congestion Mitigation and Air Quality (CMAQ) program provides funding for projects that help reduce emissions and meet national air quality standards, such as transportation demand management programs, bicycle and pedestrian improvements, transit projects, diesel retrofits, and vehicle emissions reductions programs. All types of non-motorized transportation projects are eligible for CMAQ funding. States are required to provide a non-federal match for program funds (which has not been the case historically for Federal lands highway funding). The City has not received CMAQ funding since 2013.

More information is available at: [http://www.fhwa.dot.gov/environment/air\\_quality/cmaq/](http://www.fhwa.dot.gov/environment/air_quality/cmaq/)

## HIGHWAY SAFETY IMPROVEMENT PROGRAM (HSIP)

The Highway Safety Improvement Program (HSIP) is a core federal-aid program with the purpose of achieving a significant reduction in traffic fatalities and serious injuries on all public roads, including non-state-owned public roads and roads on tribal lands. The HSIP requires a data-driven, strategic approach to improving highway safety on all public roads that focuses on performance. Highway safety improvement projects can be either infrastructure or non-infrastructure projects. ODOT administers HSIP funding through the All Roads Transportation Safety (ARTS) program described below. The HSIP program requires a local match for projects where HSIP funding will be used. For Oregon, this local match is 7.78 percent of the project cost.

More information on the HSIP Program is available at: <https://safety.fhwa.dot.gov/hsip/>

## FEDERAL LANDS ACCESS PROGRAM (FLAP)

The Federal Lands Access Program (FLAP) was established to improve transportation facilities that provide access to, are adjacent to, or are located within Federal lands. FLAP funds can be used to supplement state and local funds for public roads, public transit, and other transportation facilities such as pedestrian and bicycle facilities. Emphasis is given to high-use recreation sites and economic generators. Applicants must submit a project application through a call for projects for the state of Oregon.

More information on the FLAP program is available at: <https://flh.fhwa.dot.gov/programs/flap/>.

---

## STATE SOURCES

---

### STATE HIGHWAY FUND

The State Highway Fund, which collects revenue from the state gas tax, a tax on heavy trucks, and licensing and registration fees, is the City's primary state revenue source. The Oregon Constitution mandates that State Highway Fund revenues be spent within the highway right-of-way, which includes roads, bike facilities, and walkways. This funding source can be used on any non-motorized transportation project if it's in a highway right-of-way. The Oregon Department of Transportation (ODOT) distributes the State Highway Fund to counties and cities statewide based on population formulas. The City of Oakridge received \$206,000 in funding from the State Highway Fund in FY 2017-18.

More information is available at: <https://www.oregon.gov/ODOT/About/Pages/Transportation-Funding.aspx>

### KEEP OREGON MOVING (HB 2017)

In August 2017, Governor Kate Brown signed an eight-year transportation tax increase to raise roughly \$5 billion for roads, bridges, mass transit, electric vehicles, and other transit options. Non-motorized transportation is a priority in this bill, with funding set aside for pedestrian and bicycle infrastructure projects across the state. House Bill (HB) 2017 affects drivers, bicyclists and payroll employees by increasing the gas tax, weight-mile tax, and other transportation-related fees such as excise tax on the sale of bicycles, new vehicles, and instituting a statewide payroll tax equivalent

to 1/10<sup>th</sup> of 1 percent of wages, deducted by employer from payment to employee. The City of Oakridge will receive approximately \$75,000 from HB 2017. In addition, the HB 2017 funds will be used to construct passing lanes on OR 58 west of the City.

More information is available at: <https://www.oregon.gov/ODOT/Pages/HB2017.aspx>

## ALL ROADS TRANSPORTATION SAFETY (ARTS)

The All Roads Transportation Safety (ARTS) program (formerly known as Jurisdictionally Blind Safety Program) is intended to address safety needs on all public roads in Oregon. By working collaboratively with local jurisdictions, ODOT expects to increase awareness of safety on all roads, promote best practices for infrastructure safety, compliment behavioral safety efforts and focus limited resources to reduce fatal and serious injury crashes in the state of Oregon. The program is data driven to achieve the greatest benefits in crash reduction and should be blind to jurisdiction. The ARTS program primarily uses federal funds from the HSIP with a required local match of 7.78 percent of the project cost.

More information is available at: <https://www.oregon.gov/ODOT/Engineering/Pages/ARTS.aspx>

## CONNECT OREGON

Connect Oregon invests in air, rail, marine, bicycle, and pedestrian infrastructure across the state to ensure that Oregon's transportation system is strong across all modes of transport. Connect Oregon funding cannot go to projects that are eligible for funding through the state highway fund or related funding sources. Projects that are submitted for Connect Oregon grant funding are eligible to receive up to 70 percent of the project costs. Seven percent of funding for Connect Oregon Parts One and Two are dedicated to non-motorized transportation projects. With the passage of HB 2017, several important changes have been made to the Connect Oregon program:

- ▶ Public transit projects can no longer be funded through Connect Oregon
- ▶ New funding sources include a vehicle dealer privilege fee and a \$15 bicycle excise tax. Funds from the bicycle excise tax can only be used on bicycle or pedestrian projects.
- ▶ For the upcoming biennium, the Oregon Transportation Commission has directed \$60 million in Connect Oregon funding to be distributed to four specific projects. As a result, Connect Oregon does not anticipate any available funding for the 2017-2019 biennium.

More information is available at: <https://www.oregon.gov/ODOT/Programs/Pages/ConnectOregon.aspx>

## STATEWIDE TRANSPORTATION IMPROVEMENT PROGRAM

The Statewide Transportation Improvement Program (STIP) is ODOT's four-year transportation capital improvement program. It is the document that identifies the funding for, and scheduling of, transportation projects and programs. It includes projects on the federal, state, city, and county transportation systems, multimodal projects (highway, passenger rail, freight, public transit, bicycle and pedestrian), and projects in the National Parks, National Forests, and Indian tribal lands. STIP project lists are developed through the coordinated efforts of ODOT, federal and local governments, Area Commissions on Transportation, tribal governments, and the public.

The STIP is divided into two broad categories: Fix-It and Enhance. The Enhance category funds activities that enhance, expand, or improve the transportation system. The project selection process for the Enhance category has undergone significant changes in the last few years and reflects ODOT's goal to become a more multimodal agency and make investment decisions based on the system as a whole, instead of for each mode or project type separately. The agency has requested assistance from its local partners in developing Enhance projects that assist in moving people and goods through the transportation system. The projects are selected through a competitive application process. The Fix-it category funds activities that fix or preserve the transportation system. These projects are developed mainly from ODOT management systems that help identify needs based on technical information for things like pavement and bridges. Non-Highway programs, a separate part of the STIP, funds non-motorized transportation projects, and Area Commissions on Transportation will help recommend these projects to ODOT.

More information is available at: <http://www.oregon.gov/ODOT/TD/STIP/Pages/default.aspx>

## SAFE ROUTES TO SCHOOL

Safe Routes to School programs are focused on getting more school-age children to walk and bike to school. ODOT provides Safe Routes to School grant funding for infrastructure programs, which help create and improve safe walking and biking routes to school, and non-infrastructure programs, which raise awareness by focusing on education and outreach. Non-motorized transportation projects related to getting schoolchildren to school safely are eligible for infrastructure program funding. HB 2017 reestablished dedicated funding to Safe Routes to School programs. The current funding cycle is focused on projects that address a safety risk factor, include a 20 percent cash match, and are within one mile of a Title I school.

More information is available at: <https://www.oregon.gov/ODOT/Programs/Pages/SRTS.aspx>

---

## COUNTY SOURCES

### LANE COUNTY ROAD FUND

This is a set of funds collected from the County's share of the state motor vehicle fund and federal timber receipts. They are limited to use within street right-of-way. These funds can be used for restoration and upgrading portions of the County roads within Oakridge which include Fish Hatchery Road, High Prairie Road, and Westfir-Oak Road.

### URBAN GROWTH MANAGEMENT AGREEMENT

An Urban Growth Management Agreement (UGMA) is an intergovernmental agreement that outlines how facilities are managed in the area outside the City limits, but inside the City's Urban Growth Boundary (UGB). The City and Lane County do not have a UGMA. The County maintains and owns all County roads within the City limits.

### ECONOMIC DEVELOPMENT ASSISTANCE PROGRAM

The Economic Development Assistance Program (EDAP) is funded through loans from the County Road Fund. Funds may be used to improve the marketability of for sale industrial properties or to improve access to existing industrial businesses. The goal of EDAP is to create family-wage jobs that directly benefit local communities.

### PAYROLL TAX

Lane Transit District is funded by revenue collected by the Oregon Department of Revenue (ODR). These taxes are a percent of wages for services provided within the Lane Transit District Boundary.

More information is available at: <https://www.ltd.org/payroll-self-employment-tax-information/>

---

## LOCAL SOURCES

### LOCAL FUEL TAX

While every state collects an excise tax on fuel, Oregon is one of only nine states that permits cities and counties to impose a local fuel tax in order to pay for street operation, maintenance and preservation activities. The taxes are paid to the City monthly by distributors of fuel. The City of Oakridge currently imposes a three cents per gallon fuel tax. This revenue is shown as the "Fuel Dealer's License Fee" in the revenue line item. The City's average revenue from the local fuel tax is \$58,000 per year.

More information is available at: [https://www.oregon.gov/ODOT/FTG/Pages/Current%20Fuel%20Tax%20Rates.aspx?wp9904=p:2#g\\_c4d3c385\\_c495\\_4c4b\\_8fa2\\_0c771edc16e5](https://www.oregon.gov/ODOT/FTG/Pages/Current%20Fuel%20Tax%20Rates.aspx?wp9904=p:2#g_c4d3c385_c495_4c4b_8fa2_0c771edc16e5).

## SYSTEM DEVELOPMENT CHARGES (SDC)

System Development Charges (SDC) are fees assessed on development for impacts created to public infrastructure. All revenue is dedicated to transportation capital improvement projects designed to accommodate growth. The City can offer SDC credits to developers that provide public improvements beyond the required street frontage, including those that can be constructed by the private sector at a lower cost. For example, an SDC credit might be given for providing end-of-trip bike facilities within the new development. The City does not currently impose SDCs.

## ECONOMIC IMPROVEMENT DISTRICTS (EID)

Transportation improvements can often be included as part of larger efforts aimed at business improvement and retail district beautification. Economic Improvement Districts collect assessments or fees on businesses in order to fund improvements that benefit businesses and improve customer access within the district. Adoption of a mutually agreed upon ordinance establishing guidelines and setting necessary assessments or fees to be collected from property owners is essential to ensuring a successful EID. The City does not currently have any EIDs.

## LOCAL IMPROVEMENT DISTRICTS (LID)

LIDs are most often used to construct projects such as streets, sidewalks, or bikeways. Through the LID process, the costs of local improvements are generally spread out among a group of property owners within a specified area. The cost can be allocated based on property frontage or other methods such as trip generation. The cost of LID projects are borne primarily by property owners, moderate administrative costs must be factored in, and the public involvement process must still be followed. If the cost of the local improvement is not 100 percent funded by property owners, the City is required to contribute the remaining unfunded portion of the improvement. The City does not currently have any designated LIDs.

## URBAN RENEWAL DISTRICTS/TAX INCREMENT FINANCING

Urban Renewal Districts are separate taxing districts created to remove blight within a district. Each Urban Renewal Plan has identified actions that will remove the blight within the District. Those actions are funded by debt financing (e.g., bonds) using the incremental tax revenue generated from improvements on private property that increase the tax assessable value of that property that then create additional property tax revenue. The additional tax revenue (i.e., tax increment) is then directed to the Urban Renewal District to be used for blight removal. This public finance method is referred to as Tax Increment Financing (TIF) and is limited to Urban Renewal in the State.

The City does not currently have an Urban Renewal District.

More information is available at: [https://www.oregon.gov/DOR/forms/FormsPubs/urban-renewal-circular\\_504-623.pdf](https://www.oregon.gov/DOR/forms/FormsPubs/urban-renewal-circular_504-623.pdf)

## GENERAL FUND (GF) REVENUES

Revenue from the City's General Fund (GF) can be allocated to transportation funding at the discretion of the City Commissioners during the annual budget process. GF revenues primarily include property taxes, use taxes, and any other miscellaneous taxes and fees imposed by the City. GF resources have the potential to fund any type of transportation expenditures but would only be available if it had increased revenues or if the City Commissioners directs funding that is traditionally allotted to other City expenditures and programs.

## LOCAL BOND MEASURES

Local bond measures, or levies, are usually initiated by voter-approved general obligation bonds for specific projects. Bond measures are typically limited by time, based on the debt load of the local government or the project under focus. Funding from bond measures can be used for right-of-way acquisition, engineering, design, and construction of transportation facilities. Transportation-specific bond measures have passed in other communities throughout Oregon. Though this funding source is one that can be used to finance a multitude of project types, it must be noted

that the accompanying administrative costs are high and voter approval must be gained. In addition, local bonds for transportation improvements will compete with local bonds for other public needs, such as fire and rescue, parks and recreation, schools, libraries, etc.

## **STREET UTILITY FEES/ROAD MAINTENANCE FEE**

The fee is based on a flat fee charged to each property, on the number of trips a particular land use generates, or some combination of both and is usually collected through a regular utility bill. For the communities in Oregon that have adopted this approach, it provides a stable source of revenue to pay for street maintenance allowing for safe and efficient movement of people, goods, and services. The City of Oakridge does not currently impose transportation utility fees.

## **OPTIONAL TAX**

Optional taxes are taxes that a taxpayer elects to pay to fund projects and improvements. Optional taxes are usually less controversial and easily collected than other taxes since they require the taxpayer to decide whether or not to pay the additional tax. The voluntary nature of the tax limits the reliability and stabledness of the funding source. In addition, optional taxes for transportation improvements will compete with optional taxes for other public needs, such as fire and rescue, parks and recreation, schools, libraries, etc. The City of Oakridge does not currently impose an optional tax.

## **USER FEES**

Fees tied to the annual registration of a vehicle to pay for improvements, expansion, and maintenance to the street system. This may be a more equitable assessment given the varying fuel efficiency of vehicles. Regardless of fuel efficiency, passenger vehicles do equal damage to the street system. The cost of implementing such a system could be prohibitive given the need to track the number of vehicle miles traveled in every vehicle. Additionally, a user fee specific to a single jurisdiction does not account for the street use from vehicles registered in other jurisdictions. The City does not currently have user fees.

## **PRIVATE DEVELOPMENT CONTRIBUTIONS**

The majority of local streets and sidewalks are paid for at the time of development by the developer who includes the cost in the sale price of the homes or properties. This will also apply to bikeways, bicycle parking, and transit facilities. In this way, the benefiting users are paying for the cost of the system installation. The City then is responsible for maintaining improvements within the public right-of-way.

# **03 | FUNDING SUMMARY**

Table 4 provides a summary of the current and potential funding sources for the City. These sources will be further explored along with potential grant opportunities throughout the development of the TSP.



**Table 4. Current and Potential Funding Source Summary**

Funding Sources	Intended User	Applicable Pedestrian and Bicycle Project Types	Currently Used By the City of Oakridge
<b>Federal Sources</b>			
FAST Act	Dedicates funding to road, bridge, bicycling, and pedestrian improvements	Sidewalks, bikeways, crossing improvements, shared-use paths	
Surface Transportation Program/ Surface Transportation Block Grant	Preserves and improves surface transportation investments from a flexible funding source	Sidewalks, bikeways, crossing improvements, shared-use paths	
Congestion Mitigation and Air Quality (CMAQ)	Dedicates funding to projects that help eliminate CO2 emissions	Sidewalks, bikeways, crossing improvements, shared-use paths	
Highway Safety Improvement Program	A safety program to provide improvements to areas in need of safety improvements	Sidewalks, bikeways, crossing improvements, shared-use paths in areas where multimodal crash history supports improvements	
Federal Lands Access Program (FLAP)	Provides funding to facilities that provide access to, are adjacent to, or are located within Federal lands.	Any pedestrian or bicycle infrastructure project that improves access to Federal lands	
<b>State Sources</b>			
State Highway Fund	Makes construction, maintenance, and operations improvements on roads and highways	Any pedestrian or bicycle infrastructure project in the highway right-of-way	✓
Keep Oregon Moving (HB 2017)	Creates a steady funding stream for statewide transportation improvements	Sidewalks, bikeways, crossing improvements, shared-use paths	✓
All Roads Transportation Safety	Uses limited funds to make the highest-impact safety improvements on roads and highways	Sidewalks, crossing improvements	
Connect Oregon	Invests in a multimodal transportation system across Oregon	Sidewalks, bikeways, crossing improvements, shared-use paths	
Statewide Transportation Improvement Program	Establishes multi-year, statewide, intermodal program of transportation projects to fund	Sidewalks, bikeways, crossing improvements	
Safe Routes to School	Focuses on infrastructure and non-infrastructure programs to improve access and safety for children to walk or bike to school	Sidewalks, bikeways, crossing improvements	
<b>County Sources</b>			
Lane County Road Fund	Funds dedicated to upgrading county roads within the right-of-way	Sidewalks, bikeways, crossing improvements	
Urban Growth Management Agreement	Sets rules for how jurisdictions will manage transportation infrastructure non-urbanized land inside an Urban Growth Boundary	Sidewalks, bikeways, crossing improvements	
Economic Development Assistance Program	Improving County road aesthetics to make them more appealing to economic development	Sidewalks, bikeways, crossing improvements, shared-use paths	
Payroll Tax	The LTD provides the Diamond Express route through Oakridge	Sidewalks, bikeways, crossing improvements at bus stop locations	
<b>Local Sources</b>			
Local Fuel Tax	Apply local fuel tax and use revenues to fund capital transportation improvements	Potential for sidewalks, bikeways, crossing improvements	✓
System Development Charges (SDC)	Uses money from local development projects to fund capital transportation improvements	Potential for sidewalks, bikeways, crossing improvements	
Economic Improvement Districts (EID)	Pools funds from area businesses to make improvements in the business district.	Potential for sidewalks, bikeways, crossing improvements	
Local Improvement Districts (LID)	Pools funds from property owners to make local transportation improvements	Potential for sidewalks, bikeways, crossing improvements	
Urban Renewal Districts/Tax Increment Financing	Raises revenue from increased property values in an area to fund localized improvements	Potential for sidewalks, bikeways, crossing improvements, shared-use paths	
General Fund (GF) Revenues	Setting aside General Fund revenues for transportation	Potential for sidewalks, bikeways, crossing improvements, shared-use paths	
Local Bond Measures	Asks voters for bond funding to finance a set list of infrastructure investments	Potential for sidewalks, bikeways, crossing improvements, shared-use paths	
Street Utility Fees/Road Maintenance Fee	Calculates trips generated for land uses and charges owners a fee relative to the number of trips	Potential for sidewalks, bikeways, crossing improvements	
Optional Tax	Collects money from taxpayers who choose to help fund local projects	Potential for sidewalks, bikeways, crossing improvements, shared-use paths	
User Fees	Charges users an annual or vehicle miles traveled fee to fund roadway improvements	Potential for sidewalks, crossing improvements	
Private Developers	Charge developers for required improvements to the system as directed by the City Development Code	Potential for sidewalks, bikeways, crossing improvements, shared-use paths	



Volume II – Appendix D  
**Technical Memorandum #4**

# DRAFT MEMORANDUM #4

**Date:** March 26, 2019 Project #: 22477  
**To:** Rick Zylstra (City of Oakridge)  
 David Helton (Oregon Department of Transportation)  
**From:** Ashleigh Ludwig, PE, Marc Butorac, PE and Jacki Gulczynski (Kittelson & Associates, Inc.)  
 Kyra Haggart and Darci Rudzinski (Angelo Planning Group)  
**Project:** City of Oakridge Transportation System Plan Update

**Subject:** FINAL Memorandum #4: Transportation System Conditions, Deficiencies, and Needs

## INTRODUCTION

This memorandum inventories and evaluates the existing and future conditions of the City of Oakridge transportation system to identify current and future needs of the transportation system. The information was obtained and assembled using Geographic Information System (GIS) maps and data provided by the City; inventory conducted using Google Earth aerial images, Bing aerial images, and site visits; and studies provided or produced by Oakridge, Lane County, and the Oregon Department of Transportation (ODOT).

The majority of the inventory and analysis results are presented in figures and tabular form with supplemental text provided, as needed, to explain the illustrated information. This memorandum will identify existing and future transportation needs based on currently adopted performance targets that will be addressed in the Transportation System Plan (TSP) Update through policies, projects, programs, pilot projects and refinement studies to improve the system.

## TABLE OF CONTENTS

<b>INTRODUCTION</b> .....	<b>1</b>
<b>TABLE OF CONTENTS</b> .....	<b>1</b>
<b>01   STUDY AREA</b> .....	<b>3</b>
Study Area .....	3
Land Use and Population .....	5
Zoning .....	5
Buildable Lands and Future Development .....	10
Activity Centers .....	14
Population Inventory .....	16
Demographics .....	16
<b>02   ROADWAY SYSTEM INVENTORY</b> .....	<b>24</b>
Street System Characteristics .....	24
Roadway Jurisdiction .....	24
Functional Classification .....	24
Facility Characteristics .....	28
Freight .....	29
Roadway Cross Section .....	31

Access Management and Spacing.....	31
Study Area Needs: Street System Inventory.....	33
<b>03   INTERSECTION AND STREET OPERATIONS .....</b>	<b>33</b>
Analysis Methodology and Performance Standards.....	33
Traffic Volumes and Operational Analysis .....	34
Existing Conditions Intersection Analysis .....	34
Future Conditions Intersection Analysis.....	37
Roadway Segment Analysis.....	40
OR 58 Traffic Volume and Speed .....	41
Intersection and Street Operations Needs.....	42
<b>04   HISTORIC CRASH DATA ANALYSIS.....</b>	<b>42</b>
Historic Crash Data.....	42
City Crash Patterns .....	42
Study Intersection Summaries .....	46
Community Safety Concerns .....	48
Safety Needs .....	49
<b>05   ALTERNATIVE TRANSPORTATION ANALYSIS.....</b>	<b>49</b>
Pedestrian and Bicycle System .....	49
Recreational Activities .....	52
OR 58 Corridor .....	53
Qualitative Multimodal Analysis .....	56
Public Transit System.....	59
Rail System .....	60
Freight .....	60
Passenger .....	60
Air Transportation System .....	62
Alternative Transportation Needs .....	62
<b>06   BRIDGE , MARINE AND PIPELINE SYSTEM.....</b>	<b>63</b>
Bridge.....	63
Pipeline .....	64
Marine.....	64
<b>07   SUMMARY OF NEEDS .....</b>	<b>64</b>
<b>APPENDICES .....</b>	<b>65</b>

# 01 | STUDY AREA

## STUDY AREA

The Transportation System Plan (TSP) focuses on the City of Oakridge Urban Growth Boundary (UGB). Several intersections and roadway segments will be evaluated during the study. The study intersections are summarized in Table 1, and the study segments are summarized in Table 2. Figure 1 illustrates the study area and study intersections and segments. The weekday PM peak hour (between 4:00pm and 6:00pm) was analyzed to capture the highest typical demand during a 24-hour weekday period. A separate count was collected at Crestview Street/E 1<sup>st</sup> Street during the school release period (2:00pm to 4:00pm) to identify the travel patterns and volumes near the schools during a typical school day. *Intersection and segment count data is provided in Appendix A.*

**Table 1. Study Intersection**

Map ID	Intersection Name	Study Time Period
1	W 2 <sup>nd</sup> Street/River Road/OR 58	Weekday PM Peak Hour 4:00-5:00pm
2	Rainbow Road/OR 58	
3	Crestview Street/OR 58	
4	Hill Street/OR 58	
5	Westfir-Oakridge Road/E 2 <sup>nd</sup> Street	
6	Westfir-Oakridge Road/High Prairie Road	
7	Crestview Street/E 1 <sup>st</sup> Street	Afternoon Peak Hour 3:00-4:00pm

**Table 2. Study Segments**

Map ID	Roadway Name	Location of Traffic Count
8	OR 58	Milepost 35.50 (east of Crestview Street)
9	OR 58	Milepost 35.40 (west of Crestview Street)
10	Beech Street	South of Union Pacific Railroad Crossing
11	Fish Hatchery Road	South of Union Pacific Railroad Crossing

H:\2222477 - Oakridge TSP Updates\Memo 4 - System Conditions and Deficiencies\Figure 1 - Study Area.mxd - aludwig - 2:57 PM 12/14/2018

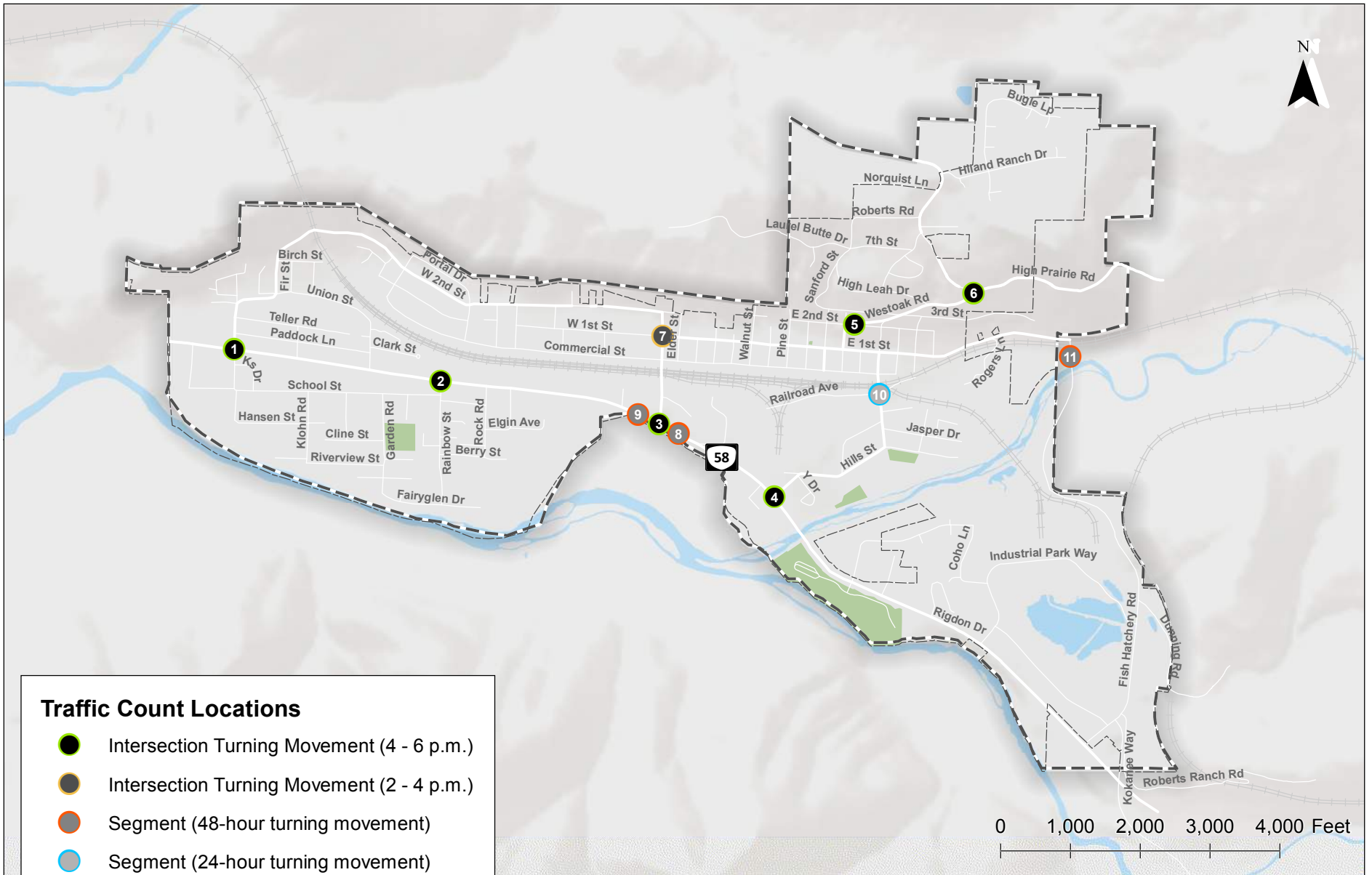

**Traffic Count Locations**

- Intersection Turning Movement (4 - 6 p.m.)
- Intersection Turning Movement (2 - 4 p.m.)
- Segment (48-hour turning movement)
- Segment (24-hour turning movement)
- Oakridge City Boundary
- Urban Growth Boundary

**Study Area  
Oakridge, Oregon**

**Figure  
1**

---

## LAND USE AND POPULATION

---

The existing land use patterns, economic development opportunities, and population and job forecasts to help inform the analysis of year 2040 transportation system needs is documented in this section. This information can also help the community and project team develop future alternatives that address transportation system deficiencies, capture the City's vision for an enhanced multimodal network, and identify the projects, programs and policies needed to support economic development in a manner consistent with the existing Comprehensive Plan and Zoning.









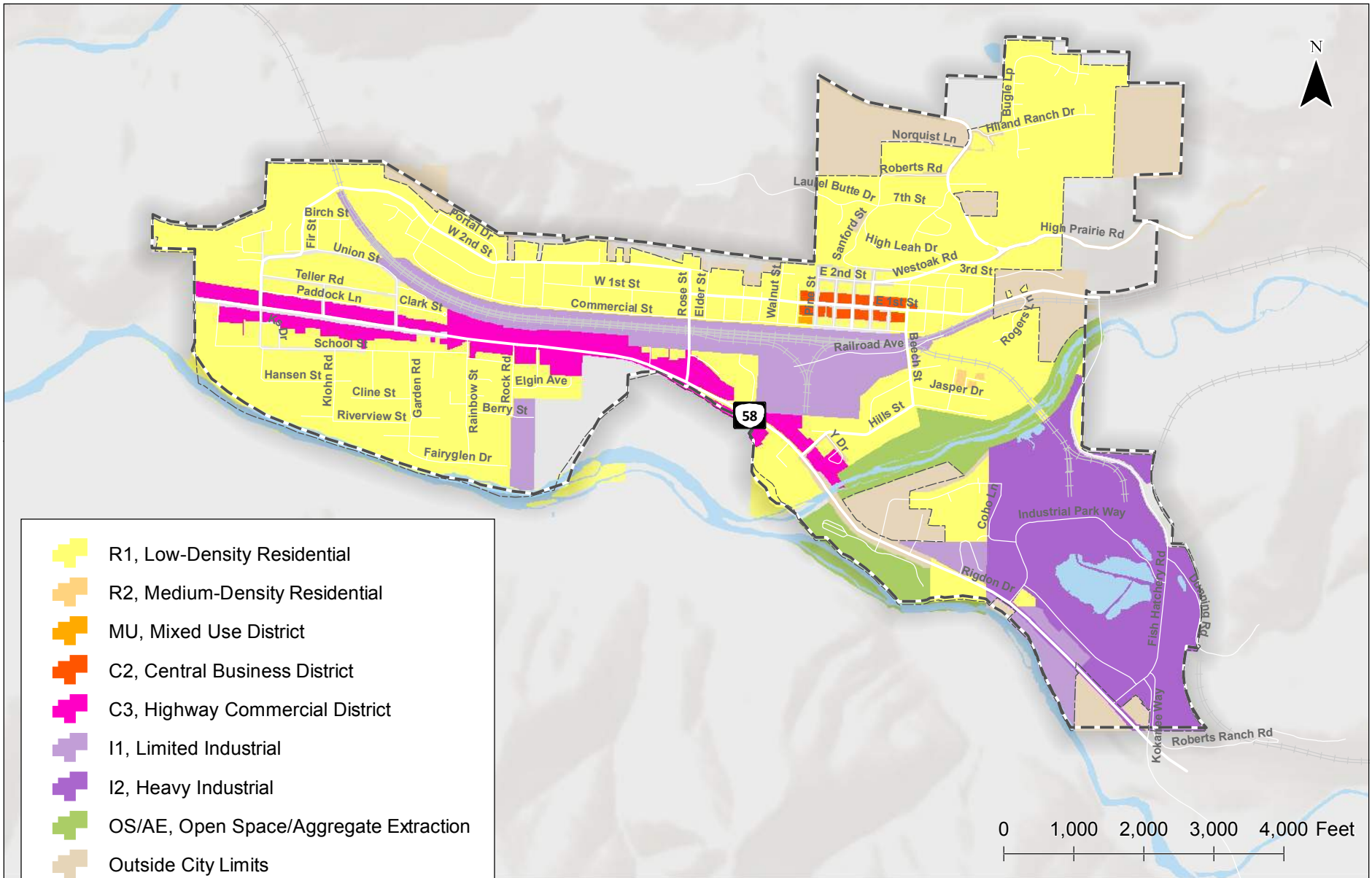

The land use and population inventory identifies existing, planned, and potential future land uses. The land use and population inventory will inform the existing and future transportation conditions analyses, which in turn will help the project team and community identify appropriate transportation projects that meet the City's needs.

### ZONING

#### Current Zoning

The zoning map, shown in Figure 2, provides the location of zoning districts within the City Limits. There are eight zones shown on the map, depicting residential, commercial, industrial, and open space/aggregate extraction zone districts. Generally, heavy industrial zoning is located in the southeast corner of the City and north of Highway 58. Limited industrial is located along the rail line running east-west through the City. Most of the commercial zoning in the City is located on either side of Highway 58, with the exception of the Central business District, which is located along E 1<sup>st</sup> Street to the north. There is a very small amount of mixed-use land located south of the central business district north of E 1<sup>st</sup> Street. Open space/aggregate extraction zoning is located along the Salmon Creek greenway in the eastern portion of the City. With approximately 53% of the City's acreage zoned R1, low-density residential zoning is by far the most prevalent zone in the City. There is a small pocket of medium-density residential zoning located in the eastern end of the City south of the railroad and north of Salmon Creek.



-  R1, Low-Density Residential
-  R2, Medium-Density Residential
-  MU, Mixed Use District
-  C2, Central Business District
-  C3, Highway Commercial District
-  I1, Limited Industrial
-  I2, Heavy Industrial
-  OS/AE, Open Space/Aggregate Extraction
-  Outside City Limits
-  Oakridge City Boundary
-  Urban Growth Boundary

**Zoning  
Oakridge, Oregon**

**Figure  
2**

H:\22\2477 - Oakridge TSP Update\GIS\Memo 4 - System Conditions and Deficiencies\Figure 2 - Zoning.mxd - bommerville - 1:54 PM 1/3/2019



Development regulations for each of the City's zones are provided for in Ordinance No. 874 of the Oakridge Code and Land Use Ordinance. Table 3 includes a list of the zones and a summary of the types of development permitted in each.

<b>Table 3. Zoning Districts</b>	
<b>Zoning District</b>	<b>Zoning District Purpose</b>
Low Density Residential (R-1)	Intended to provide a quality environment for all residential urban uses, with compatible non-residential land uses, as determined to be desirable or necessary. (2-9 dwelling units per acre.)
Medium Density Residential (R-2)	Intended to provide an environment suitable for urban living; designed to be applied to residential uses and appropriate community services over a wide range of residential densities. (9 dwelling units per acre and higher.)
Neighborhood Commercial (C-1) <sup>1</sup>	Intended to serve the day-to-day needs of a small support population, typically an adjacent residential neighborhood.
Central Commercial (C-2)	Intended to enhance the "core" of the City and promote a vibrant area where retail sales, light manufacturing and residential uses coexist in harmony and are safe, comfortable and attractive to pedestrians.
Highway Commercial (C-3)	Intended to provide essential services to the traveling public, together with certain other highway-related commercial uses providing services and goods to the consumer population of the City and the immediate region.
Mixed Use (M-1)	Intended to allow residential, commercial, light industrial and public uses to coexist in the same environment.
Light Industrial (I-1)	Intended to provide areas suitable for limited manufacturing, warehousing, and similar activities that have minimal effect on the surrounding areas of the community.
Heavy Industrial (I-2)	Intended to provide areas for industries that are primarily engaged in the processing of raw materials into refined materials in large volumes.
Open Space/Aggregate Extraction (OS/AE)	Intended to (1) allow for the extraction of aggregate resources for the construction industry; (2) provide for reclamation of the area following termination of extraction activities; (3) provide for fish and wildlife habitat through the protection of riparian vegetation, spawning beds, marshes, and other features; (4) ensure coordination of federal, state, and local plans and permits for the beneficial, multi-purpose management of the river channel and bank areas; (5) provide for channel maintenance to help flood control and prevention activities; (6) provide for recreational opportunities.
Public Facilities (PF)	Intended to allow for development and modification of public facilities without requiring the City to go through the conditional use permit process.
Park, Recreation and Open Space (PRO)	Intended to ensure that land for park and recreation use is developed to serve its intended use while not disrupting nearby land uses.

<sup>1</sup> There are currently no taxlots with C-1 zoning in the City of Oakridge; however the zone is still included in the City's zoning code.

The Oakridge Zoning Ordinance also includes seven (7) subdistricts, listed below. These subdistricts establish additional requirements, standards, and procedures for the use and development of property in the underlying zoning district.

- ▶ Flood Plain Subdistrict (FP)
- ▶ Mobile Home Park Subdistrict (MHP)
- ▶ Manufactured Home Subdivision Subdistrict (MHS)
- ▶ Planned Unit Development Subdistrict (PUD)
- ▶ Airport Safety Subdistrict (AS)
- ▶ Old Town Design Subdistrict (OT)
- ▶ Highway 58 Design Subdistrict (HD)

## Planned Zoning

For areas that are within the Urban Growth Boundary (UGB) but have not yet been annexed into the City Limits, the City's Comprehensive Plan designations indicate the intended future zoning of parcels in those areas. Figure 3 shows the City's currently adopted Comprehensive Plan designations.

The majority of the land located inside the City's UGB but outside the City Limits is designated Urban Residential with the exception of a small pocket of land designated Parks, Recreation, and Open Space. The Urban Residential designation is implemented by the R-1 zone and is intended to provide opportunities for low-density single-family development on larger lots.

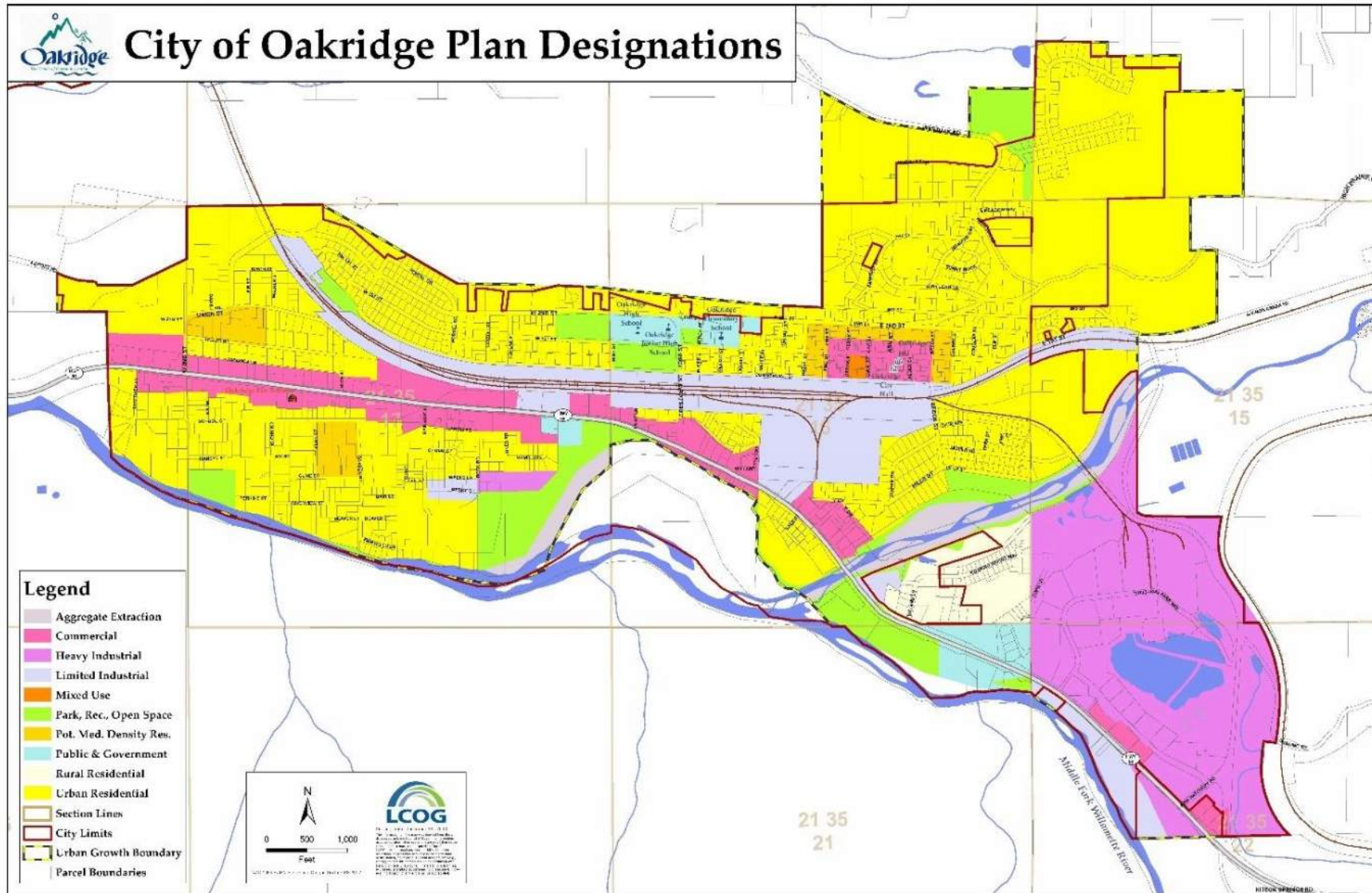

Figure 3. Comprehensive Plan Designations

## BUILDABLE LANDS AND FUTURE DEVELOPMENT

An inventory of developed and vacant land was produced using assessor property classification data for tax lots within the City Limits. Tax assessor information for parcels within the City of Oakridge provides a basic inventory of developed and vacant land, which is mapped in Figure 4 and Figure 5.

As shown in Figure 4, residential uses are the most common land use in the City of Oakridge. Current residential uses are primarily low-density single-family homes, with several pockets of multifamily housing in the southern part of the City along or near to Highway 58. Commercial uses are also primarily clustered along the Highway or along E 1<sup>st</sup> Street, which serves as the City's main street. Most of the City's current industrial uses are located in the Oakridge Industrial Park in the southeast corner, north of Highway 58. Farm and forest uses are primarily located along the northern edges of the City. The parcel of vacant forest land on High Prairie Road is directly adjacent to the Willamette National Forest, which surrounds the City of Oakridge.

Vacant land in the City of Oakridge is primarily located on the eastern side of the City, with the majority of vacant parcels zoned or designated for future low-density residential uses. The majority of vacant land in the City is located in the northeastern corner of the UGB. This area is buildable but is characterized by relatively steep slopes that may hinder future development (see Figure 6). The largest of these parcels is nearly 40 acres located at the eastern terminus of Hiland Ranch Drive and is owned by Hiland Ranch Properties Inc. The Hiland Ranch parcel was flagged for potential residential development in the tax assessor's property classification. There are 26 vacant lots located along Highway 58 and E 1<sup>st</sup> Street that are within commercial zoning districts and may be likely to develop in the future. A significant portion of the Oakridge Industrial Park remains vacant as well.<sup>2</sup> The park has received Industrial Site Certification for meeting the criteria set forth by the Governor's Economic Revitalization Team, and the City states that it will provide assistance in obtaining permits, financial assistance, workforce training, and tax incentives for prospective developers.

---

<sup>2</sup> <http://www.oakridge.or.Citygovt.org/Default.aspx?tabid=2837>

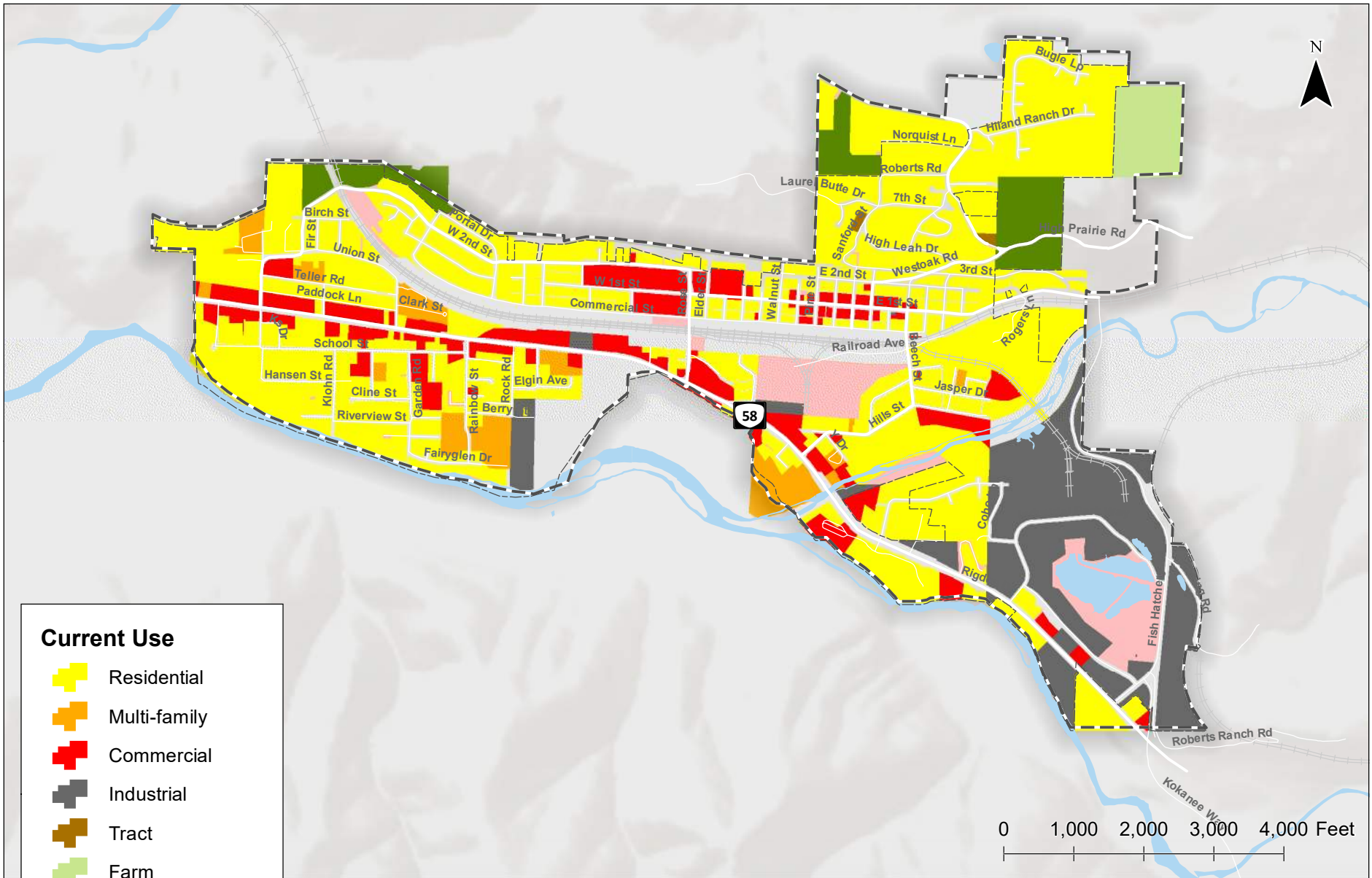

**Current Use**

- Residential
- Multi-family
- Commercial
- Industrial
- Tract
- Farm
- Forest
- Misc. Unbuildable

**Current Uses  
Oakridge, Oregon**

**Figure  
4**

N:\Projects\02-4063 Oakridge TSP Update\GIS\MXDs\CurrentUse.mxd - kyra - 4:28 PM 1/7/2019



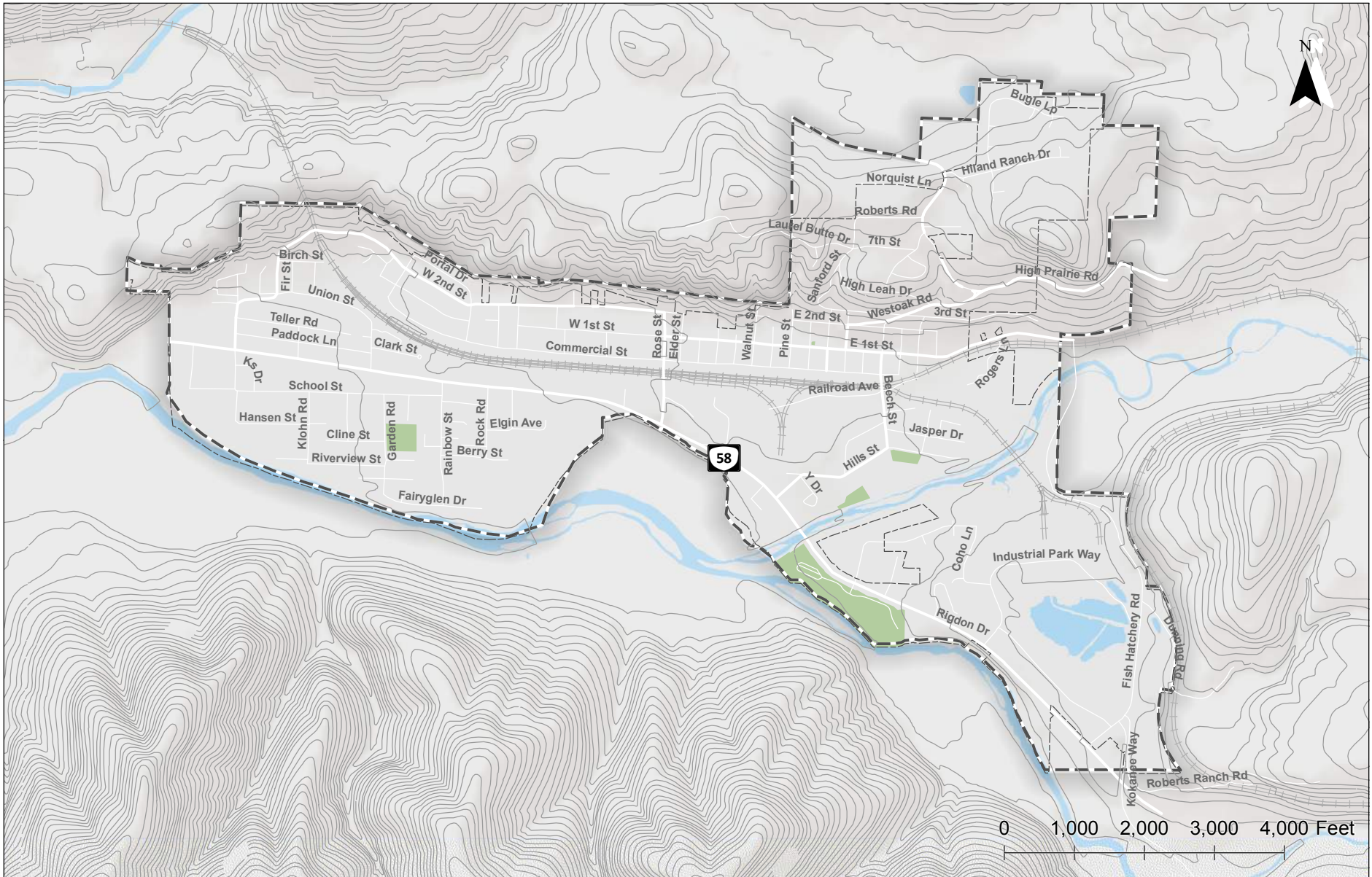

**40ft Contour Lines  
Oakridge, Oregon**

**Figure  
6**

H:\22\22477 - Oakridge TSP Update\gis\Terrain.mxd - jsomerville - 1:42 PM 11/26/2018

## ACTIVITY CENTERS

It is important to provide safe and efficient multimodal connections to and between major activity centers in the community. The activity centers identified in the City of Oakridge include a variety of civic, educational, and recreational uses. As seen in Figure 7, activity centers are generally clustered around E 1<sup>st</sup> Street, Commercial Street, and Highway 58. Some prominent destinations outside of these primary activity areas include the Oakridge State Airport, which is located west of the City, and the Willamette Fish Hatchery to the east in the Willamette National Forest. Activity centers identified in the City of Oakridge include:

- ▶ City Hall
- ▶ Police and Fire Stations
- ▶ The Oakridge Museum
- ▶ Oakridge High School, Junior High School, and Elementary School
- ▶ Green Waters Park
- ▶ Oakridge State Airport
- ▶ Orchid Health Clinic
- ▶ Willamette Activity Center
- ▶ Willamette Fish Hatchery



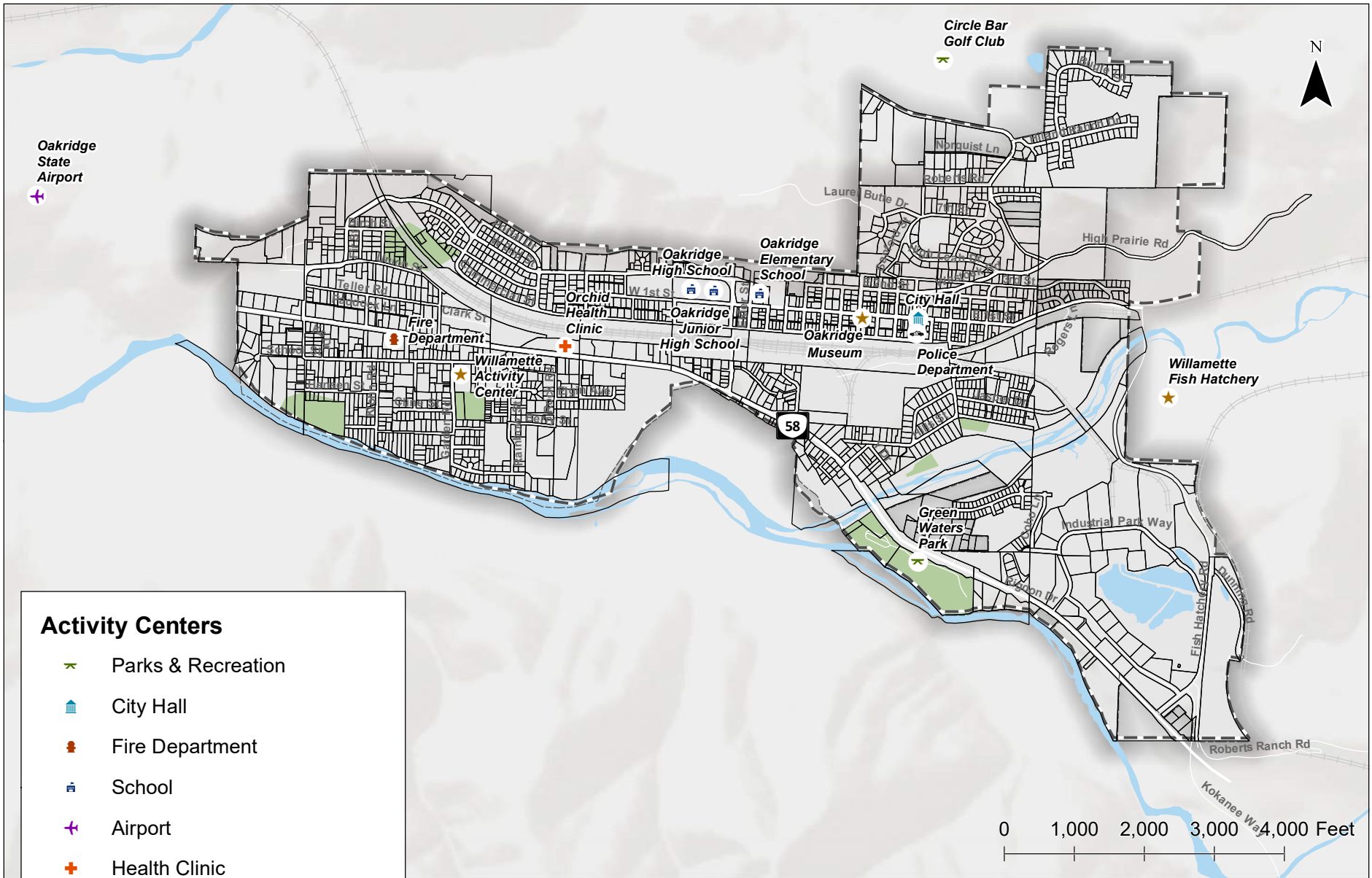

**Activity Centers**

- Parks & Recreation
- City Hall
- Fire Department
- School
- Airport
- Health Clinic
- Police Department
- Cultural & Community Centers

**Activity Centers  
Oakridge, Oregon**

**Figure  
7**

N:\Projects\02-4063 Oakridge TSP Update\GIS\MXDs\ActivityCenters.mxd - kyle - 5:04 PM 1/17/2019

## POPULATION INVENTORY

By Oregon Revised Statute 195.034, incorporated cities and counties are directed to formulate and adopt coordinated population projections. Further, the Statute requires that population projections for cities be prepared by the Portland State University (PSU) Center for Population Research. Table 4 shows the 2010 and 2017 population as well as the latest population projections, shown for 2020-2060, that were prepared in 2015 for Lane County. The table illustrates the total County population and the City of Oakridge population. Oakridge represents approximately 0.8% of the County's total population. Between 2017 and 2040, the population forecasts for Oakridge result in an estimated increase of 215 people, or approximately 0.3 percent increase per year. This population projection will inform the updated Transportation System Plan (TSP).

Year	Lane County (Total)	Oakridge
2010	351,880	3,205
2017	374,748	3,294
2020	377,798	3,358
2030	413,693	3,435
2040	442,478	3,509
2050	469,118	3,580
2060	498,805	3,650

Source 2010 from the US Census Bureau

## DEMOGRAPHICS

The City's transportation system should be designed and operated with the needs and safety of all travelers in mind, including people of all ages and abilities. To help shape the future bicycle, pedestrian, transit, and street system plans, the City has assembled information related to the key geographic areas serving the minority, low income, elderly, youth, and transportation disadvantaged populations. Each of these key population segments are identified in detail in the following figures.

As shown in Figure 8 through Figure 13, there are several key areas for consideration when planning the transportation system and needed improvements over a 20-year time horizon, including:

- ▶ Approximately one third of children (18 years of age or younger) live within a half mile radius of the schools. This provides an opportunity for kids to walk or bike to school. Approximately one third of the City's youth population live on the southside of OR 58. This requires students to cross the highway and railroad if they chose to walk or bike to school.
- ▶ The elderly population is dispersed throughout the City. The Senior and Disabled Services building is located in the southwest region of the City, while a Senior Meal Services Site is located in the southeast region of the City. There is currently a volunteer dial-a-ride service provided for seniors in the community.
- ▶ The highest proportion of non-English-speaking residents are in areas in the southwest of the City. Additionally, high portions of households without vehicles are in the southwest and northeast areas of the City. There are currently no transit stop locations near these areas. Providing for transportation choices to single occupancy vehicle travel and for easy-to-understand wayfinding information in these areas should be further evaluated.
- ▶ The City is home to a population with a diverse range of incomes and a fairly high percentage of low-income residents. The highest population of low-income households is located east of Crestview Street. As noted in the bullets above, the evaluation of future transit service options will be of particular importance to providing transportation choices to this segment of the population.

- ▶ The highest concentration of disabled persons is west of Crestview Street. The evaluation of transit service to this area, in particular, will need further consideration as part of the TSP update to ensure viable options to single occupancy vehicle travel are provided.

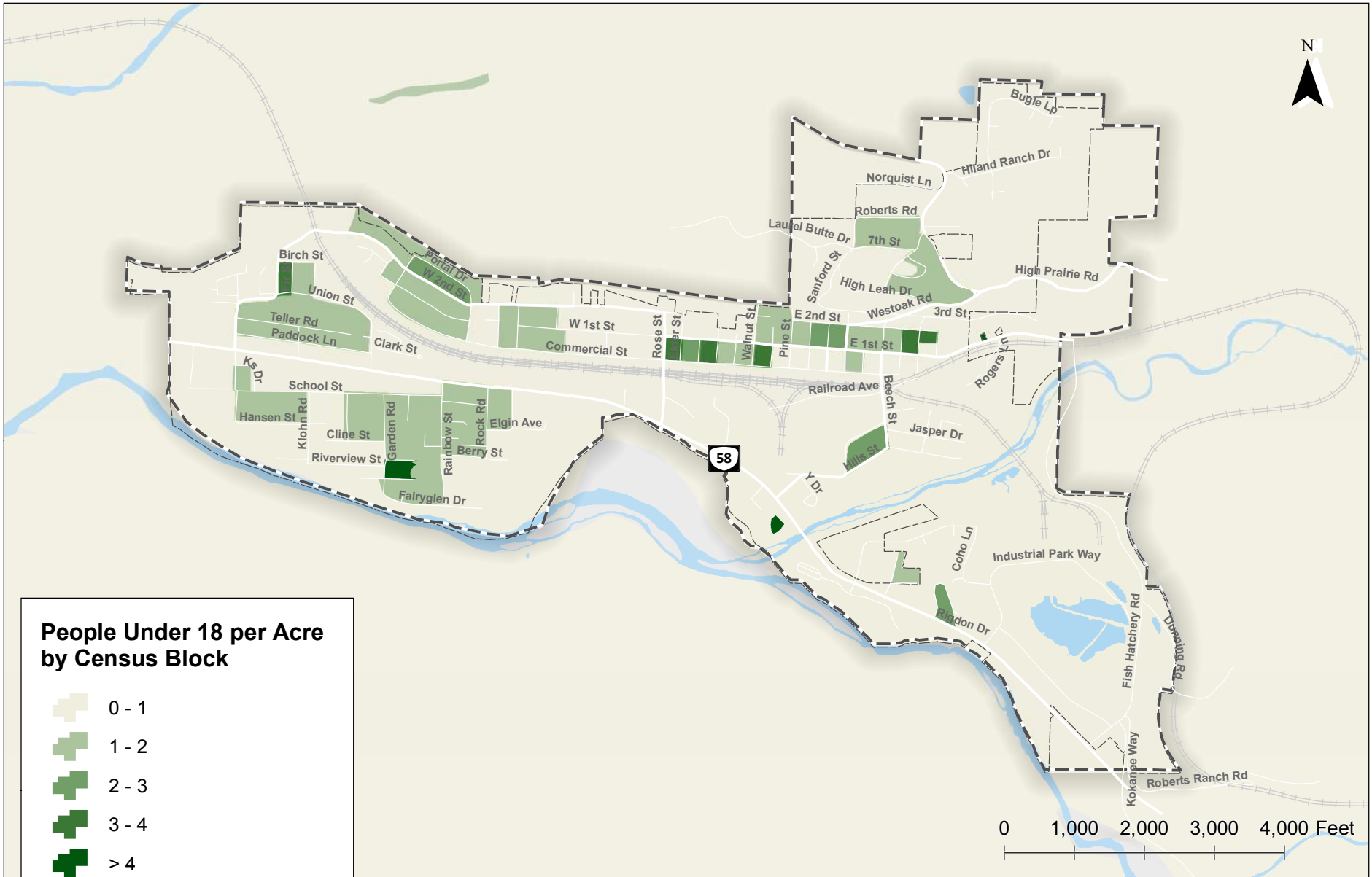

**People Under 18 per Acre  
by Census Block**

- 0 - 1
- 1 - 2
- 2 - 3
- 3 - 4
- > 4

- Oakridge City Boundary
- Urban Growth Boundary

**Youth Population  
Oakridge, Oregon**

**Figure  
8**

H:\22\2477 - Oakridge TSP Update\gis\Youth Population.mxd - iguleczynski - 3:09 PM 12/14/2018



**People Over Age 64 per Acre by Census Block**

- 0
- 0 - 1
- 1 - 2
- 2 - 3
- 3 - 4

Oakridge City Boundary  
 Urban Growth Boundary

**Elderly Population  
Oakridge, Oregon**

**Figure  
9**

H:\22\2477 - Oakridge TSP Update\gis\Elderly Population.mxd - jguczynski - 3:12 PM 12/14/2018



**Minorities per Acre  
by Census Block**

- 0
- 0 - 1
- 1 - 2
- 2 - 5
- 11

- Oakridge City Boundary
- Urban Growth Boundary

0 1,000 2,000 3,000 4,000 Feet

**Minority Population  
Oakridge, Oregon**

**Figure  
10**

H:\22\2477 - Oakridge TSP Update\gis\Minority Population.mxd - jgultczynski - 3:13 PM 12/14/2018

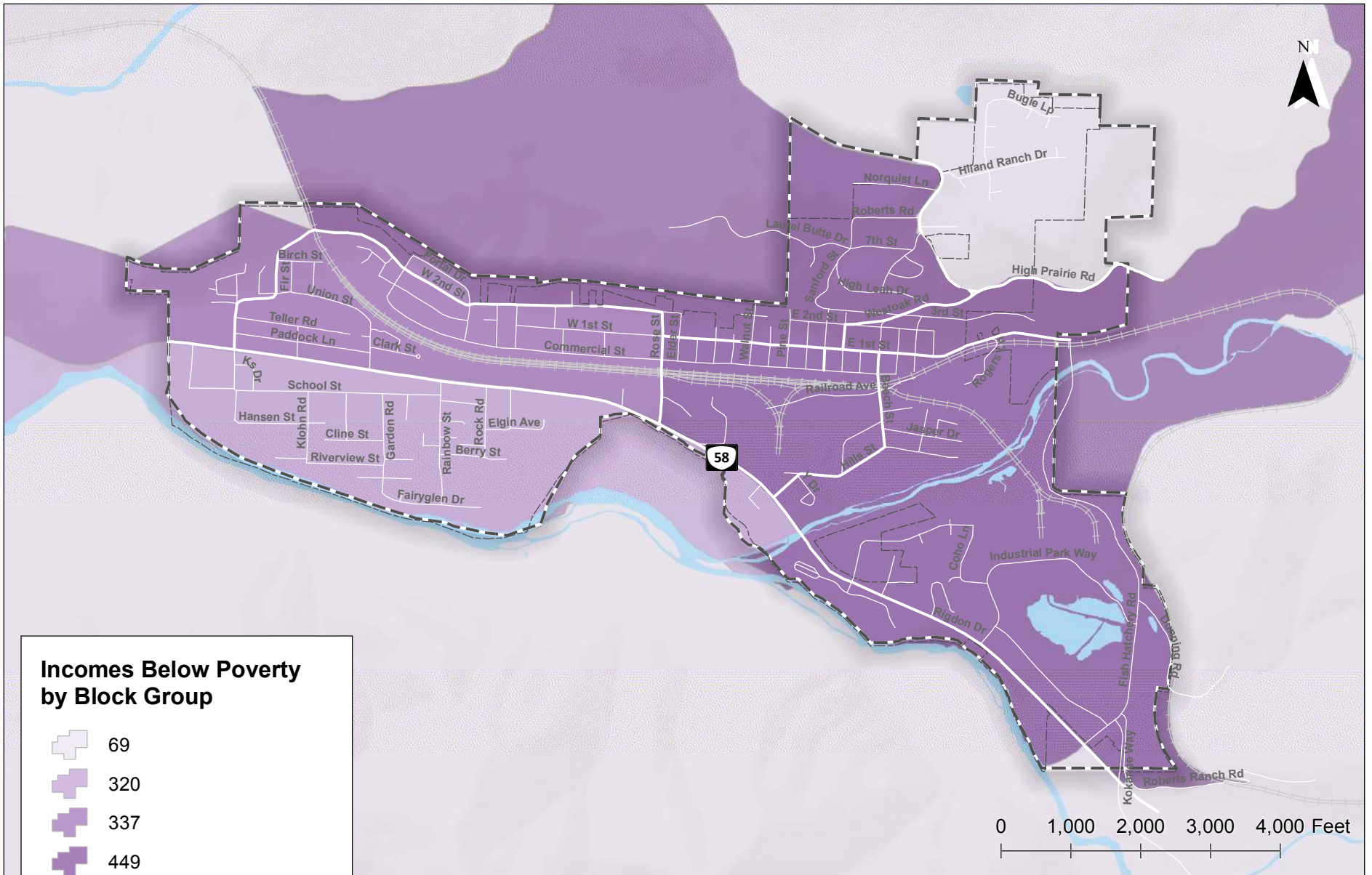

**Incomes Below Poverty by Block Group**

- 69
- 320
- 337
- 449
- Oakridge City Boundary
- Urban Growth Boundary

**Low Income Population  
Oakridge, Oregon**

**Figure  
11**

H:\22\2477 - Oakridge TSP Update\gis\Low Income Population.mxd - jgulczynski - 3:14 PM 12/14/2018

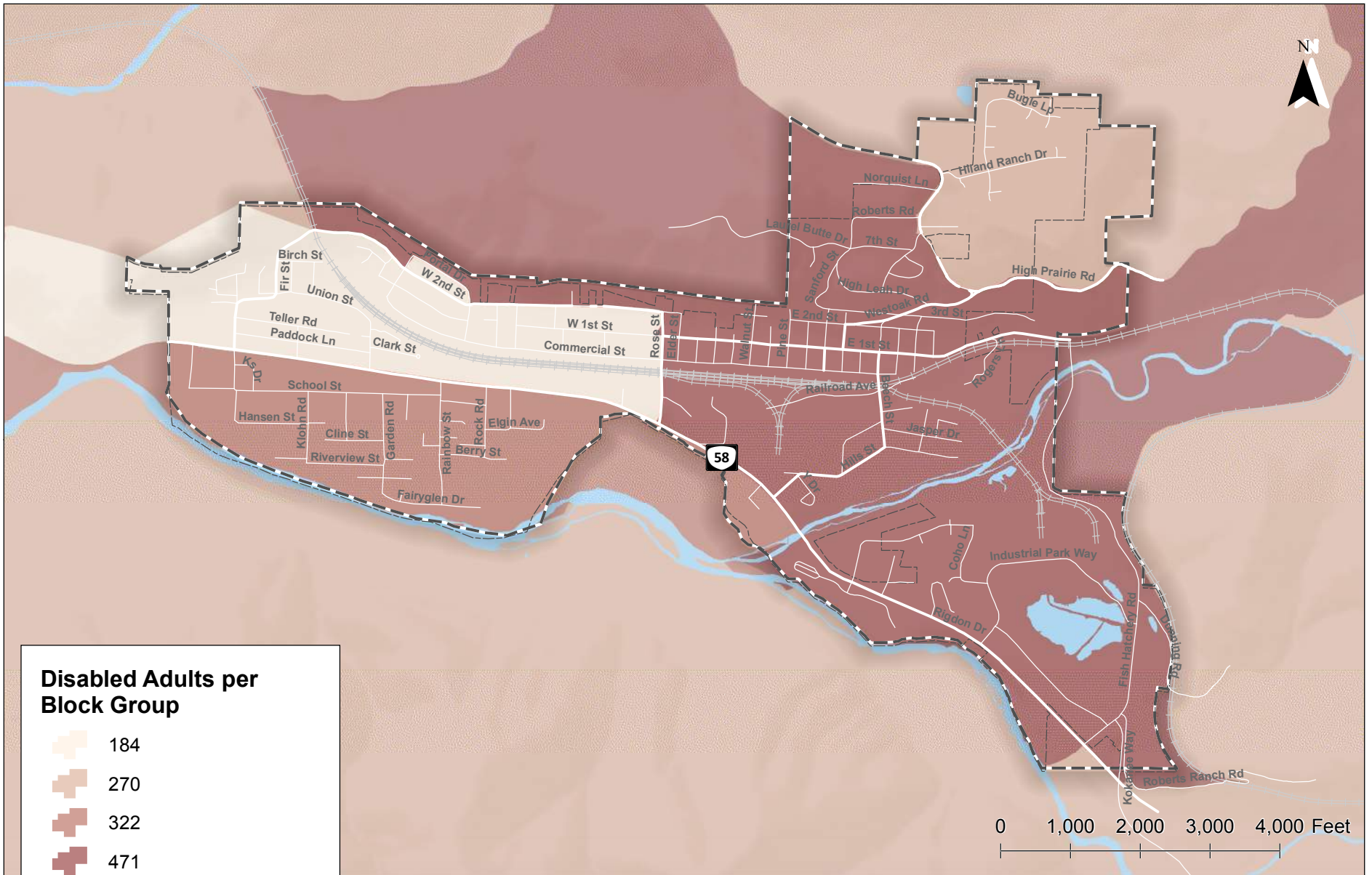

**Disabled Adults per Block Group**

- 184
- 270
- 322
- 471

Oakridge City Boundary

Urban Growth Boundary

**Disabled Population  
Oakridge, Oregon**

**Figure  
12**

H:\22\2477 - Oakridge TSP Update\gis\Disabled Population.mxd - jgulczynski - 3:17 PM 12/14/2018



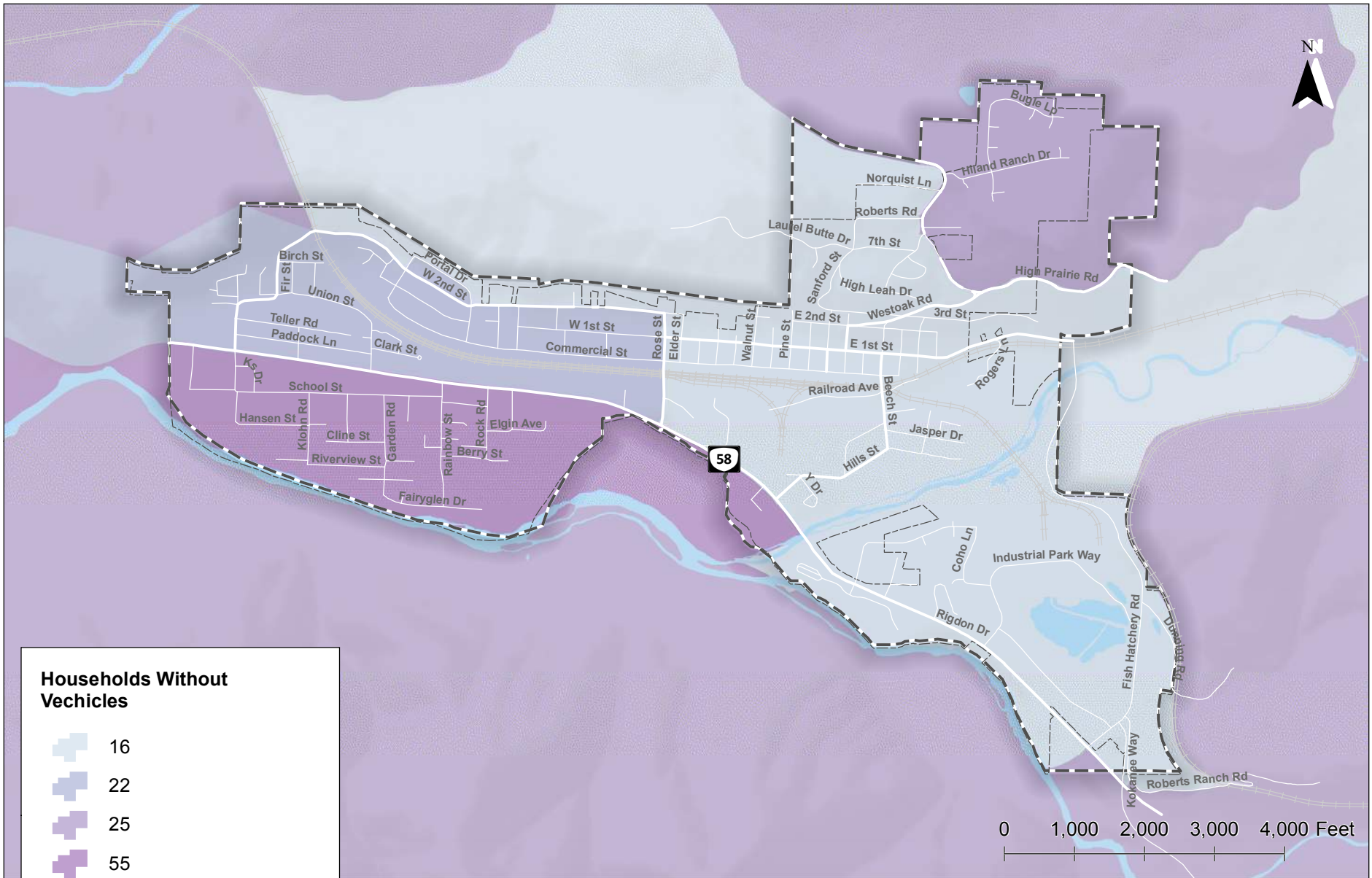

**Households Without Vehicles**

- 16
- 22
- 25
- 55

- Oakridge City Boundary
- Urban Growth Boundary

**Transportation Disadvantaged Population  
Oakridge, Oregon**

**Figure  
13**

H:\22\2477 - Oakridge TSP Update\gis\Transportation Disadvantaged Population.mxd - jgulczynski - 3:18 PM 12/14/2018

## 02 | ROADWAY SYSTEM INVENTORY

The evolution of the City's arterial, collector and local streets has been shaped, in large part, by the presence of the railroad, OR 58, and several waterways. The street system is an important conveyance of personal travel, freight, public transit, and emergency response. This section summarizes the existing street system inventory.

### STREET SYSTEM CHARACTERISTICS

#### ROADWAY JURISDICTION

The majority of streets within the Oakridge are owned and maintained by the City. The Oakridge roadway jurisdiction map is shown in Figure 14. As shown in the figure, Highway 58 is an ODOT facility. Lane County owns and maintains High Prairie Road, Westoak Road, Fish Hatchery Road, and Dunning Road. All remaining roadways are owned and maintained by the city or privately controlled and maintained.

#### FUNCTIONAL CLASSIFICATION

The City, County, and ODOT organize streets into a functional classification system based on a hierarchy of multimodal mobility and access to, through and between different land use types. The TSP inventory focuses on those streets classified as collectors and arterials.

Functional classification levels for roadways are used to establish a hierarchy of roadways based on their primary function (moving people across regions or providing access to local destinations). These classification levels are identified by ODOT for state facilities and the City for City facilities. The classification levels also determine the recommended roadway cross-section for different facilities. The functional classification of roadways that local agencies typically establish is based on the following hierarchy:

- ▶ **Arterials** represent the highest class of roadway. These roadways are intended to provide mobility by serving high volumes of traffic, particularly through traffic, at higher speeds. They also serve truck movements and should emphasize traffic movement over local land access. In some cases, arterial streets are further designated as "major/principal" or "minor." Major/principal arterials have higher design speed, fewer accesses per mile, and usually do not permit direct private driveway access. Minor arterials provide slightly lower travel speeds and have a few more accesses than major/principal arterials. Oakridge examples of Arterial roadways include:
  - Crestview Street
  - E 1<sup>st</sup> Street
  - Westoak Road
- ▶ **Collectors** represent the intermediate roadway class. As their name suggests, these roadways collect traffic from the local street system and distribute it to the arterial street system. These roadways provide a balance between traffic movement and land access and should provide extended continuous stretches of roadway to facilitate traffic circulation through the county. Collector streets are sometimes divided into two categories –major collector and minor collector. Major collectors may be longer in length, have higher posted speed limits, have lower access point density, have more lanes, and carry higher traffic volumes compared to minor collectors. Oakridge examples of Collector roadways include:
  - Union Street
  - School Street
  - Rainbow Road

- Commercial Street

- ▶ **Local** roads and streets are the lowest roadway class. Their primary purpose is to provide local land access and to carry locally generated traffic at relatively low speeds compared to the collector street system. Local streets should provide connectivity through neighborhoods but should be designed to discourage cut-through vehicular traffic.

Figure 15 illustrates the current functional classification of roadways within Oakridge. The current functional classification system includes several short segments of arterials between two collector roadways. Because the primary purpose of arterials is to carry through traffic, arterial routes are often long routes connecting through the City. The current functional classification system does not provide a continuous east-west arterial route other than Highway 58. The current functional classification system will be reviewed as part of the alternatives analysis for the TSP update.

Several roadways were identified in the initial screening process that should be considered for reclassification. These updates include increasing the classification (to a collector or arterial) for:

- ▶ Hills Street
- ▶ Commercial Street
- ▶ School Street
- ▶ Fish Hatchery Road
- ▶ W 2<sup>nd</sup> Street



H:\22\2477 - Oakridge TSP Update\GIS\Memo 4 - System Conditions and Deficiencies\Figure 15 - Roadway Functional Classifications.mxd - aludwig - 2:37 PM 12/14/2018

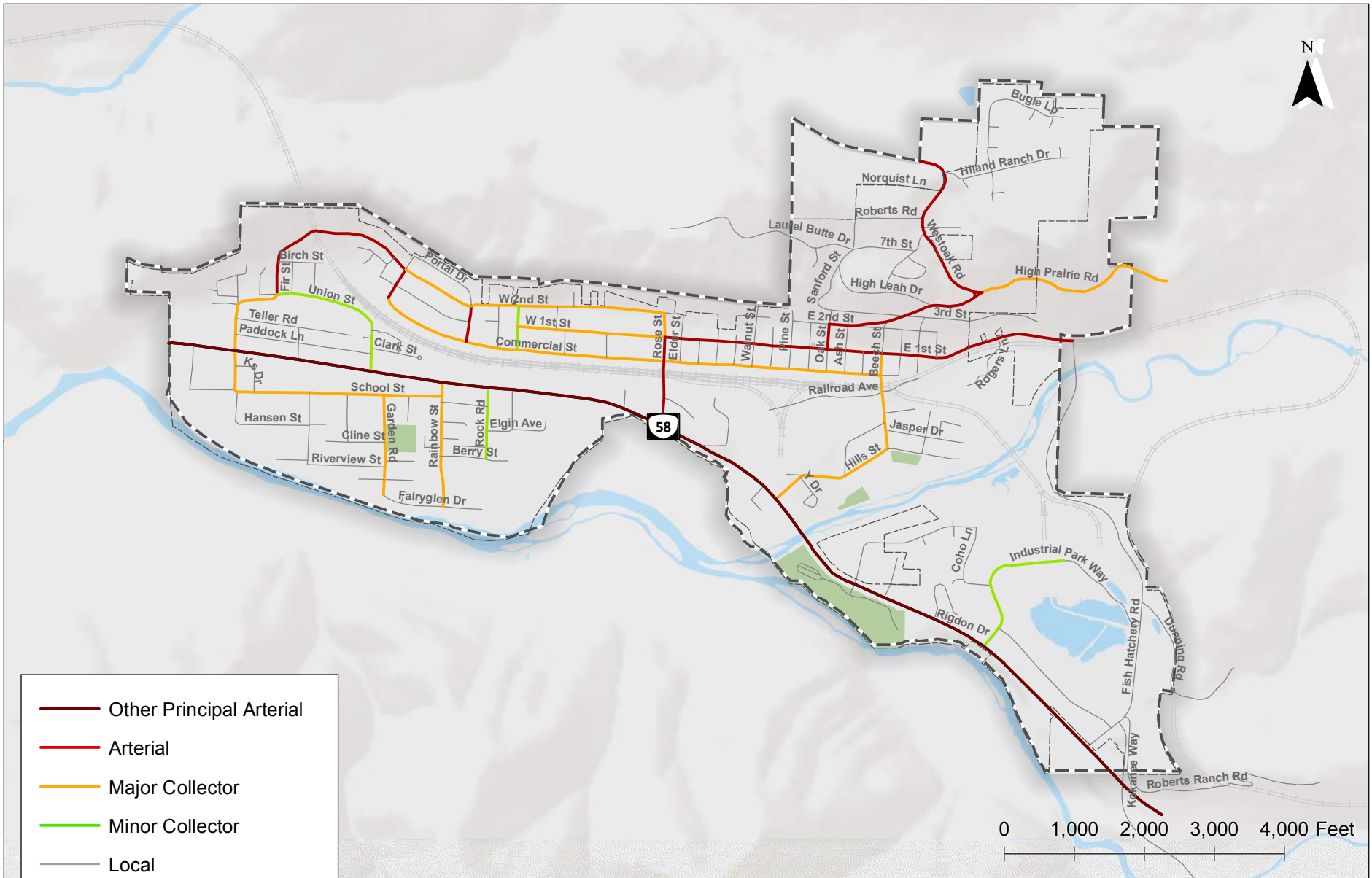

- Other Principal Arterial
- Arterial
- Major Collector
- Minor Collector
- Local
- Oakridge City Boundary
- Urban Growth Boundary

**Roadway Functional Classifications  
Oakridge, Oregon**

**Figure  
15**

## FACILITY CHARACTERISTICS

### State Facilities

State highways provide statewide and regional connections within Oregon. There is one state highway located in Oakridge: OR 58. OR 58 extends from Eugene to US 97 in Central Oregon. OR 58 connects the city's residents, employees, and visitors with other areas in Western and Central Oregon as well as throughout the state. OR 58 also provides connections within the city. At the same time, the highway can present a barrier to walking and cycling within and through the City. Table 5 summarizes the OR 58 highway characteristics. OR 58 has a posted speed of 55 mph east and west of the city limits. Transition zones reduce the speed from 55 miles per hour to 35 miles per hour within city limits. As of 2017, the pavement condition for OR 58 within the City limits was indicated as "Fair".

OR 58 is primarily a two-lane roadway outside of the City but transitions into five lane road (including a two-way center turn lane) between Thatcher Lane and Hyland Lane. The multilane cross-section creates a defacto passing lane on OR 58 within the City, which may result in vehicles traveling at higher speeds. The transition back to two-lane on the east side of the City results in an eastbound lane-drop at the entrance to the Industrial Park. This results in potential conflicts between vehicles attempting to complete last-minute passing movements in the left-lane and vehicles waiting to turn left into the Industrial Park.

**Table 5. OR 58 Highway Characteristics**

Facility Extents	Oregon Highway Plan (OHP) Designation	Posted Speed Limit (mph)	Number of Lanes	Travel Lane Width	Pavement Condition
Entire Section within City Limits	Statewide Highway	35 mph (transitioning up to 55 mph near city edges)	2-5	11-12 feet	Fair

### County Facilities

The county has jurisdiction over 2.75 miles of roadways within the city limits of Oakridge. The county facilities within the City provide connections to state highways, the City of Westfir, unincorporated communities, and local destinations such as the National Forest and reservoirs. Several notable county roads within City limits include: Westoak Road, High Prairie Road, and Fish Hatchery Road. Fish Hatchery Road was identified in the previous TSP as a roadway that would be transferred to City jurisdiction; however, the road remains under county control.

### City Facilities

The remainder of the roadways in the City fall under City jurisdiction and are therefore owned and maintained by the City. With the exception of the Uptown area (E 1<sup>st</sup> Street), most roads are unstriped without curb and gutter. E 1<sup>st</sup> Street has a combination of parallel and angle on-street parking in the Uptown area.

There is one signalized intersection within the City at Crestview Street and OR 58. All other intersections are stop controlled. All City roads are designated as 25 miles per hour with the exception of a 20 miles per hour speed zone near the schools when children are present.

## FREIGHT

OR 58 is a major freight route and key east-west connection through the state. Freight is a critical component of the Oakridge and regional economy. Figure 16 shows the designated freight routes throughout the city. As shown, OR 58, which is part of the State Highway Freight System, is the only designated freight route within City limits. OR 58 is also designated as a Reduction Review Route, which are "ODOT facilities that require review of during planning, project development, development review, and maintenance to examine their "hole in the air" capacity."



According to the tube count data collected in July 2018, over 20 percent of the vehicles on OR 58 near Crestview Street are heavy vehicles. OR 58 is part of the State Highway Freight System and is a federally designated freight route.

Freight is also transported on numerous city and county roadways to access industrial and commercial locations. Tube counts indicated that over 15 percent of traffic on Beech Street and Fish Hatchery Road is heavy vehicle traffic.

Several needs related to the freight system were identified:

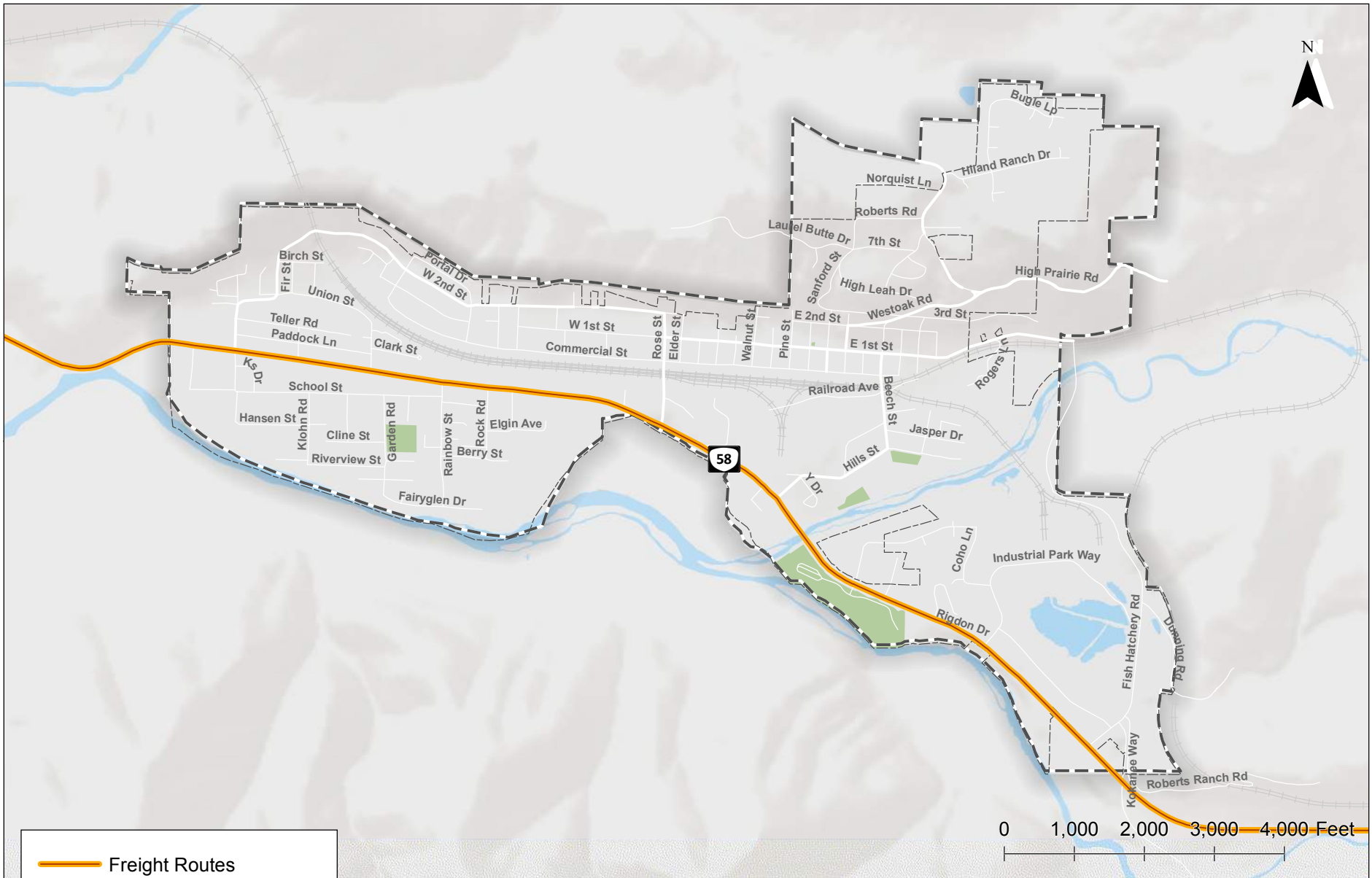
- ▶ The Oregon Freight Plan indicates passing lanes may be necessary east and west of the City UGB, if lane conversions occur in the City.
- ▶ The City lacks freight routes off of the state highway system. In particular, there are no designated freight routes within the industrial park.
- ▶ There are no designated truck stops or safe truck parking locations on OR 58 between Eugene and Chemult. Generally, truck stop accommodations include refueling, food options, showers, and on-site truck parking spaces. While diesel pumps are provided at various gas stations along OR 58, there are no locations that include additional accommodations for truck drivers.



-  Freight Routes
-  Oakridge City Boundary
-  Urban Growth Boundary

**Freight Routes  
Oakridge, Oregon**

**Figure  
16**

H:\22\22477 - Oakridge TSP Update\gis\Freight Routes.mxd - jguczynski - 3:23 PM 12/14/2018



## ROADWAY CROSS SECTION

The City's current roadway standards are shown in Table 6 and are based on the roadway functional classification. *Appendix B includes images of the existing cross sections for each functional classification.* Each classification shows a typical section with and without on-street parking.

The ODOT Highway Design Manual (HDM) specifies a sidewalk should be a minimum of six feet if there is no buffer between the curb and the sidewalk. A landscaping buffer provides separation between motorists and pedestrians. The current standard shows a 5.5-ft wide sidewalk for collectors and local streets, slightly less than the Oregon guidance. Where possible, a landscaping or buffer strip should be considered.

**Table 6. Oakridge Functional Classification and Cross Section Standards**

Functional Classification	Right of Way (ft)		Paving Width (ft)*		Sidewalk (ft)	Bike Lane (ft)	Optional Planter Strip (ft)
	Min.	Max.	Min.	Max.			
Arterial	60	120	34	48	6.5	6	3-5
Major Collector	50	80	34	46	5.5	6	3-5
Minor Collector	50	80	34	46	5.5	6 (If required)	3-5
Local	40	60	20	36	5.5	Not required	3-5

\*Paving width varies depending on the combination of travel lanes (10' to 12' wide), center turn lanes (12' wide), and parking lanes (7' to 8' wide) provided. See Appendix B for the combinations permitted.

## ACCESS MANAGEMENT AND SPACING

Providing adequate access to streets, land uses, and key destinations is a critical part of operating and planning for an effective transportation system for all users. ODOT, the County, and the City all maintain standards to help balance the needs for both "through travelers" (including freight and public transportation) as well as serving the needs of area residents, employees and visitors. The following subsections identify current standards for streets within Oakridge.

Access management strategies and implementation require careful consideration to balance access and mobility in a safe and efficient manner. In general, access management is generally more stringent on higher classified roads where mobility is the highest priority. Figure 17 illustrates the relationship between access and mobility relative to the street classifications in Oakridge.

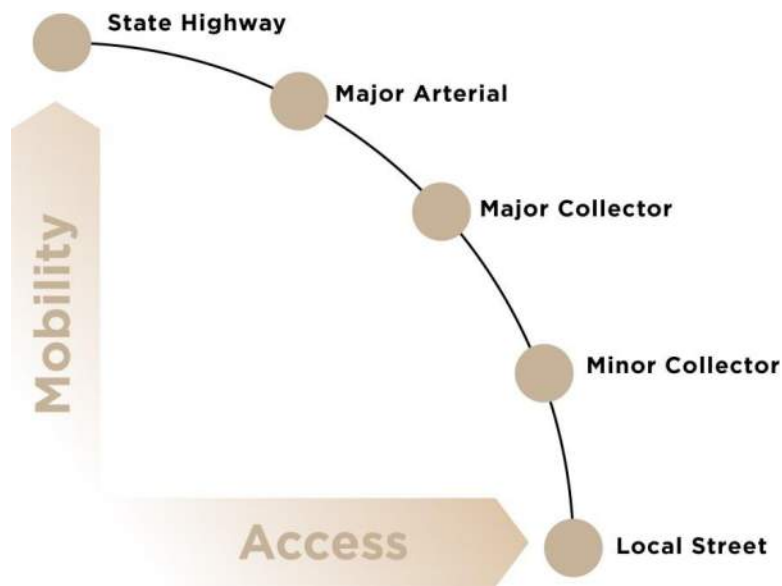

**Figure 17. Relationship between Access, Mobility, and Functional Classification**

## State Facility

ODOT specifies access management spacing standards in the Oregon Highway Plan (OHP) and OAR 734-051-4020(8). The applicable access management spacing standards for OR 58 within the Oakridge City limits are summarized in Table 7. These standards are based on the 2017 AADT (Annual Average Daily Traffic volume), posted speed limit, and functional classification. OR 58 in Oakridge exceeds 5,000 AADT within City limits.

Table 7. ODOT Access Management Spacing Standards	
Posted Speed	Access Spacing
35 mph	500 ft
45 mph	800 ft
55 mph	1,320 ft

Source: Oregon Highway Plan, Appendix C Revisions to Address Senate Bill 264 (2011) Table 14

## County and City Facilities

The City of Oakridge's access management spacing standards are summarized in Table 8 and vary based on functional classification. In cases where physical constraints or characteristics limit the ability to achieve the access spacing standards, the City of Oakridge retains the right to grant an access spacing variance. Within the UGB, Lane County applies the City's access management standards.

Table 8. City Access Spacing Standards	
Functional Classification	Access Spacing
Arterial	150 ft
Major Collector	75 ft
Minor Collector	50 ft
Local	25 ft

---

## STUDY AREA NEEDS: STREET SYSTEM INVENTORY

---

The following needs (gaps or deficiencies) were identified based on the existing street system characteristics:

- ▶ The current functional classification system lacks east-west connected and continuous arterials.
- ▶ The freight system does not designate any City or County roads as freight routes. There are no designated freight routes serving the industrial area.
- ▶ The Oregon Freight Plan identifies a need for passing lanes on OR 58. The multilane cross section within city limits creates a defacto passing lane.
- ▶ The transition back to a two-lane section on the east end of town results in potential conflicts for eastbound vehicles attempting to complete passing movements in the left-lane and those waiting to turn left into the Industrial Park.
- ▶ There are limited options for truck stops on OR 58 between Eugene and Chemult.
- ▶ The City's current roadway standards identify sidewalks with minimum widths less than 6 feet.

## 03 | INTERSECTION AND STREET OPERATIONS

Existing and future traffic operations at seven key intersections were completed to identify where strategic capital improvements can be focused within the existing system as well as where new roadways may be needed to serve future economic development and associated multimodal travel.

---

## ANALYSIS METHODOLOGY AND PERFORMANCE STANDARDS

---

The intersection operational evaluations were conducted consistent with Methodology Memorandum and the ODOT Analysis Procedures Manual (APM). *The methodology memorandum is provided in Appendix C.* Intersection operational evaluations were conducted based on the peak 15-minute flow rate observed during the weekday peak hour. Using the peak 15-minute flow rate means this analysis is based on a reasonable worst-case scenario. For this reason, the analysis reflects the conditions that are likely to occur for 15 minutes out of each average weekday peak hour. The transportation system will likely operate under conditions better than those described in this report during other typical time periods.

The operational results for the intersections and segments were compared with applicable City, State and/or County performance standards to identify existing and future deficiencies. These standards are shown in Table 9. ODOT defines intersection performance standards by "mobility targets" that are represented by a volume-to-capacity (v/c) ratio, a commonly used quantitative measure of traffic service. It generally varies between 0 and 1, where low v/c ratios represent sufficient capacity and ratios approaching 1 indicate that the roadway is approaching capacity. Ratios exceeding 1.0 indicate that a roadway exceeds capacity. The County and City define performance standards by "level-of-service", which is a qualitative measure of traffic that rates service on a scale from A to F, with LOS A indicating free flowing conditions and LOS F indicating congested conditions with higher delay.

**Table 9. County Mobility Standards**

Map ID	Intersection	Jurisdiction	Traffic Control	Mobility Standard
1	River Road/OR 58	ODOT	TWSC	0.95 N-S/0.85 E-W
2	Rainbow Road/OR 58	ODOT	TWSC	0.95 N-S/0.85 E-W
3	Crestview Street/OR 58	ODOT	Signal	0.85 (overall intersection)
4	Hill Street/OR 58	ODOT	TWSC	0.95 N-S/0.85 E-W
5	Westfir-Oakridge Road/E 2 <sup>nd</sup> Street	County	TWSC	LOS E, v/c=0.95
6	Westfir-Oakridge Road/High Prairie Road	County	TWSC	LOS E, v/c=0.95
7	Crestview Street/E 1 <sup>st</sup> Street	City	TWSC	LOS E, v/c=0.95

## TRAFFIC VOLUMES AND OPERATIONAL ANALYSIS

The following sub-sections discuss the weekday peak hour traffic volume development at study intersections and study segments.

### EXISTING CONDITIONS INTERSECTION ANALYSIS

Traffic counts at six of the study intersections were completed during the p.m. peak hour (4:00 – 6:00 p.m.) in July 2018. Two-hour weekday afternoon (2:00 – 4:00) peak hour traffic counts were collected at the intersection of Crestview Street/E 1<sup>st</sup> Street due to the proximity to schools. The afternoon traffic counts capture the school dismissal period.

Seasonal adjustment factors were applied to the counts to develop peak hour traffic volumes for the 30<sup>th</sup> Highest Hour (30 HV), consistent with the ODOT Analysis and Procedures Manual methodology. The methodology memo in Appendix C documents the seasonal adjustments applied. Figure 18 shows the existing peak hour volumes, and Figure 19 shows the intersection operations analysis results at the study intersections. The study intersections operate within their respective performance targets under existing conditions.

*Existing conditions intersection operation sheets are provided in Appendix D.*

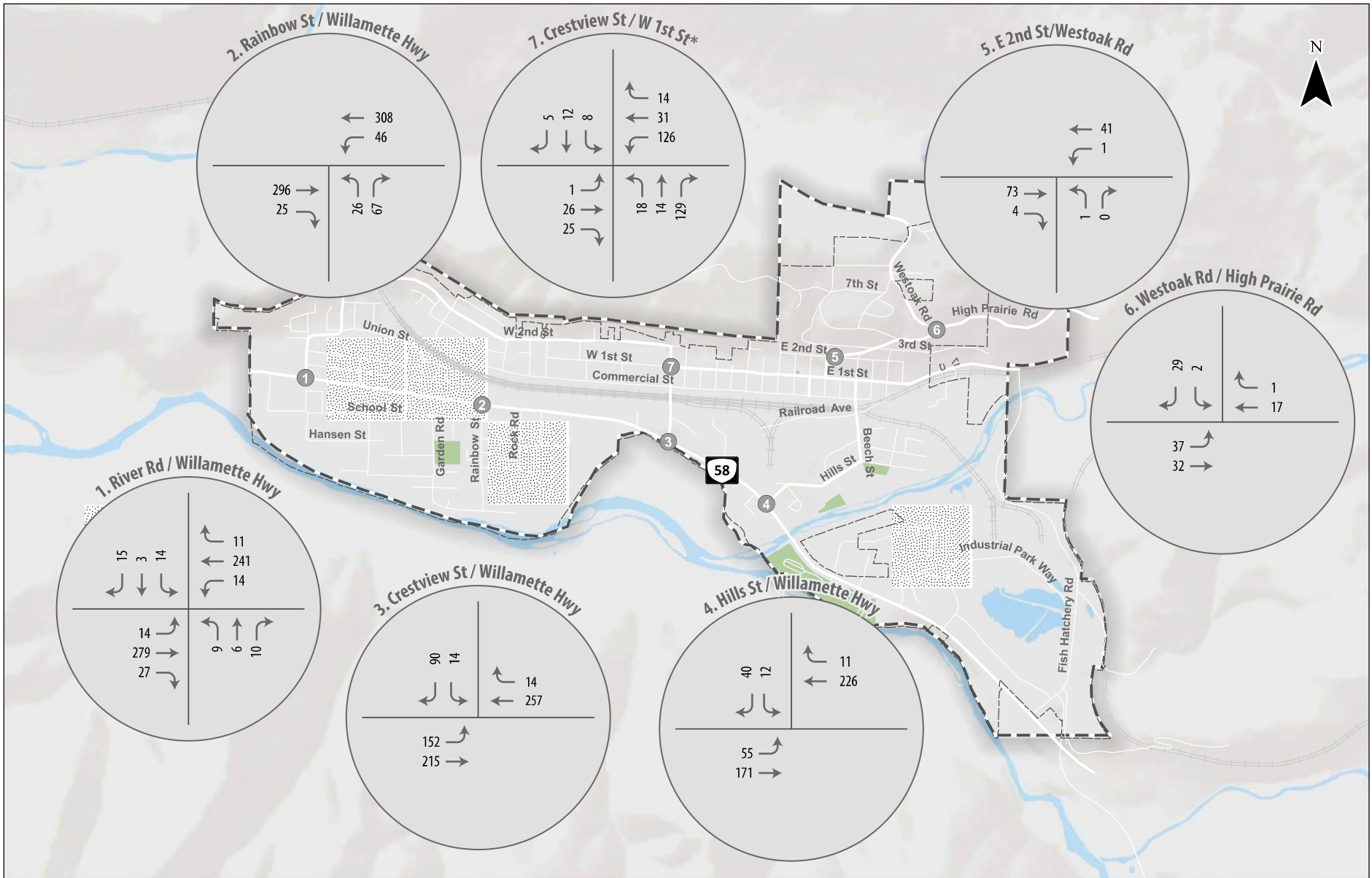

PM Peak Traffic Volume

\*Crestview St/W 1st Street reflects the afternoon peak due to school proximity

Existing (2018) Peak Hour Traffic Volumes  
Oakridge, Oregon

Figure  
**18**

H:\2020\2477 - Oakridge TSP Update\GIS\VolumeBaseMap.mxd - sfhyne - 3:21 PM 11/29/2018

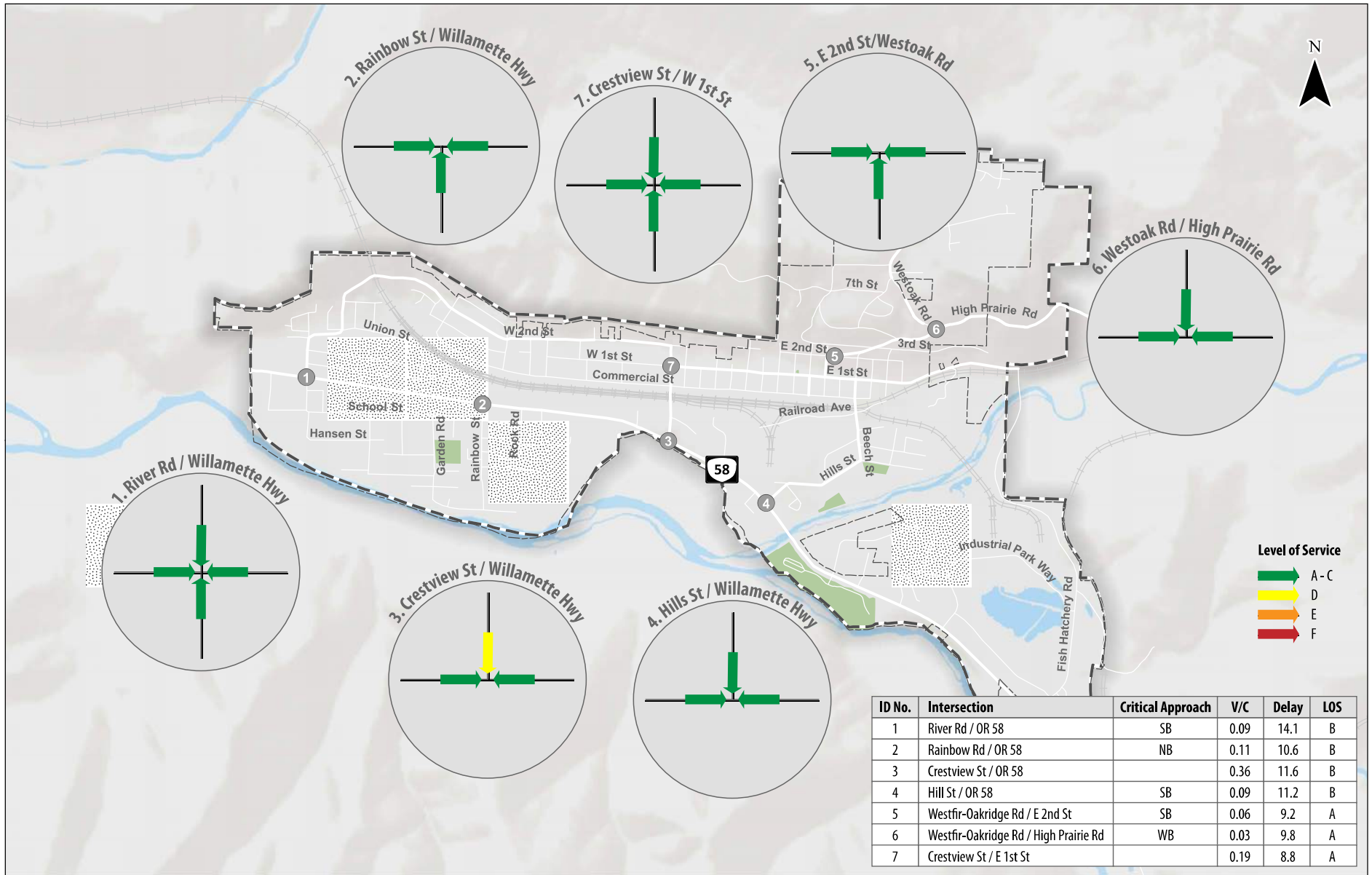

Existing (2018) Peak Hour Intersection Operations  
Oakridge, Oregon

Figure  
**19**

H:\2020\2477 - Oakridge TSP Update\GIS\VolumeBaseMap.mxd - sphyne - 3:21 PM 11/29/2018

## FUTURE CONDITIONS INTERSECTION ANALYSIS

The TSP analyzes intersection operations during the horizon year (2040) to estimate how the system will operate approximately 20 years in the future and identify where operational improvements may be needed. The methodology used to develop the future volumes is provided in the methodology memo in Appendix C. The resulting annual average growth rates applied to the 2018 traffic volumes were 1.25 percent per year for ODOT facilities and 0.50 percent per year for City and County facilities.

Figures 20 and 21 show the peak hour volumes and intersection operations analysis results at the study intersections during future 2040 conditions, respectively. The study intersections are expected to operate within their respective performance targets in future 2040 conditions.<sup>3</sup>

*Future intersection operation sheets including v/c, delay, LOS, and 95<sup>th</sup> percentile queue lengths, are provided in Appendix E.*

---

<sup>3</sup>The southbound approach at the intersection of OR58/Crestview Street is forecast to improve from LOS "D" to LOS "C" in 2040, despite the increase in traffic due to growth. This is due to a phf of 0.95 used for all future analyses.

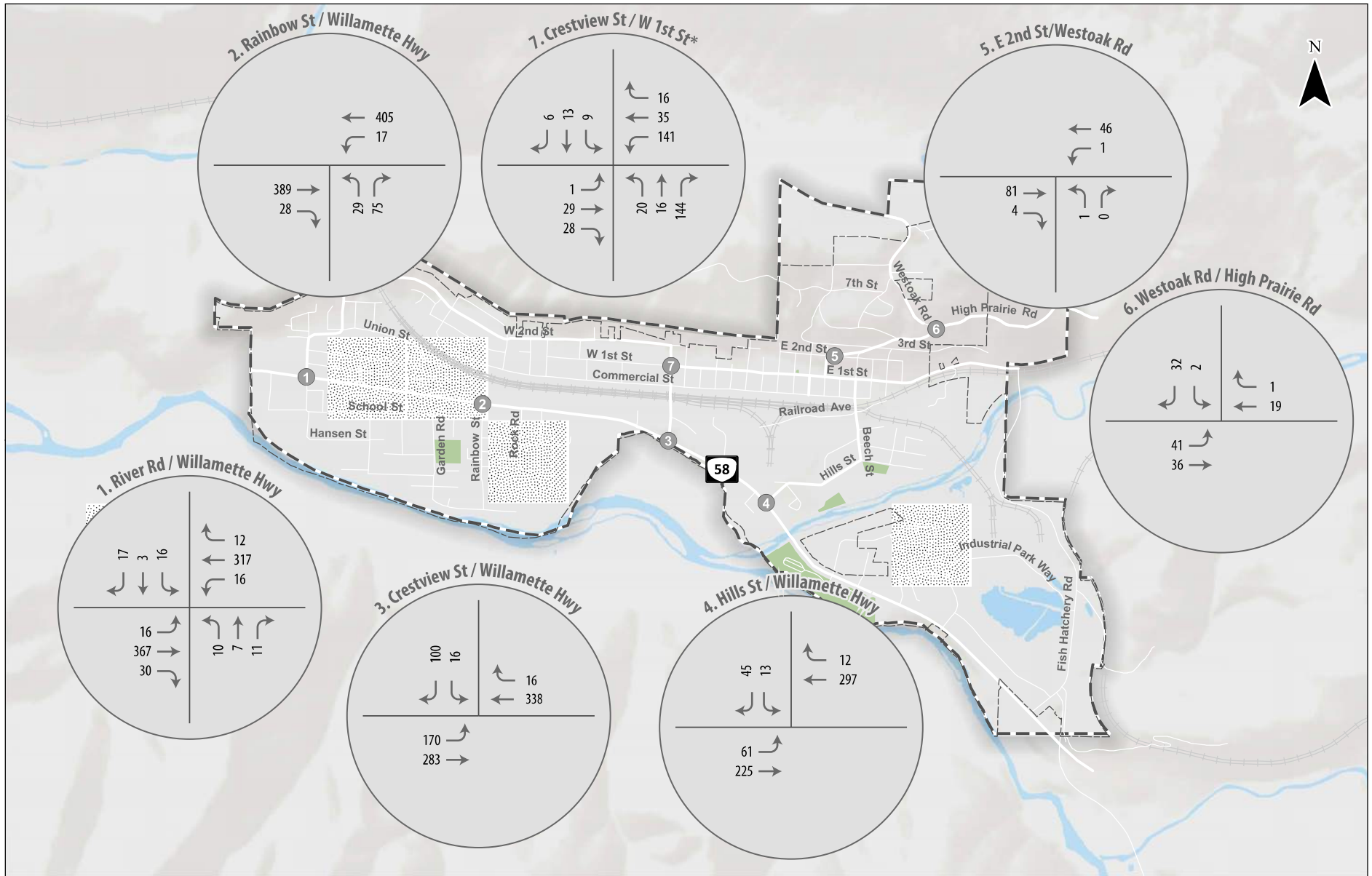

PM Peak Traffic Volume

\*Crestview St/W 1st Street reflects the afternoon peak due to school proximity

Future (2040) Peak Hour Traffic Volumes  
Oakridge, Oregon

Figure  
**20**

H:\2020\2477 - Oakridge TSP Update\GIS\VolumeBaseMap.mxd - sflyne - 3:21 PM 11/29/2018



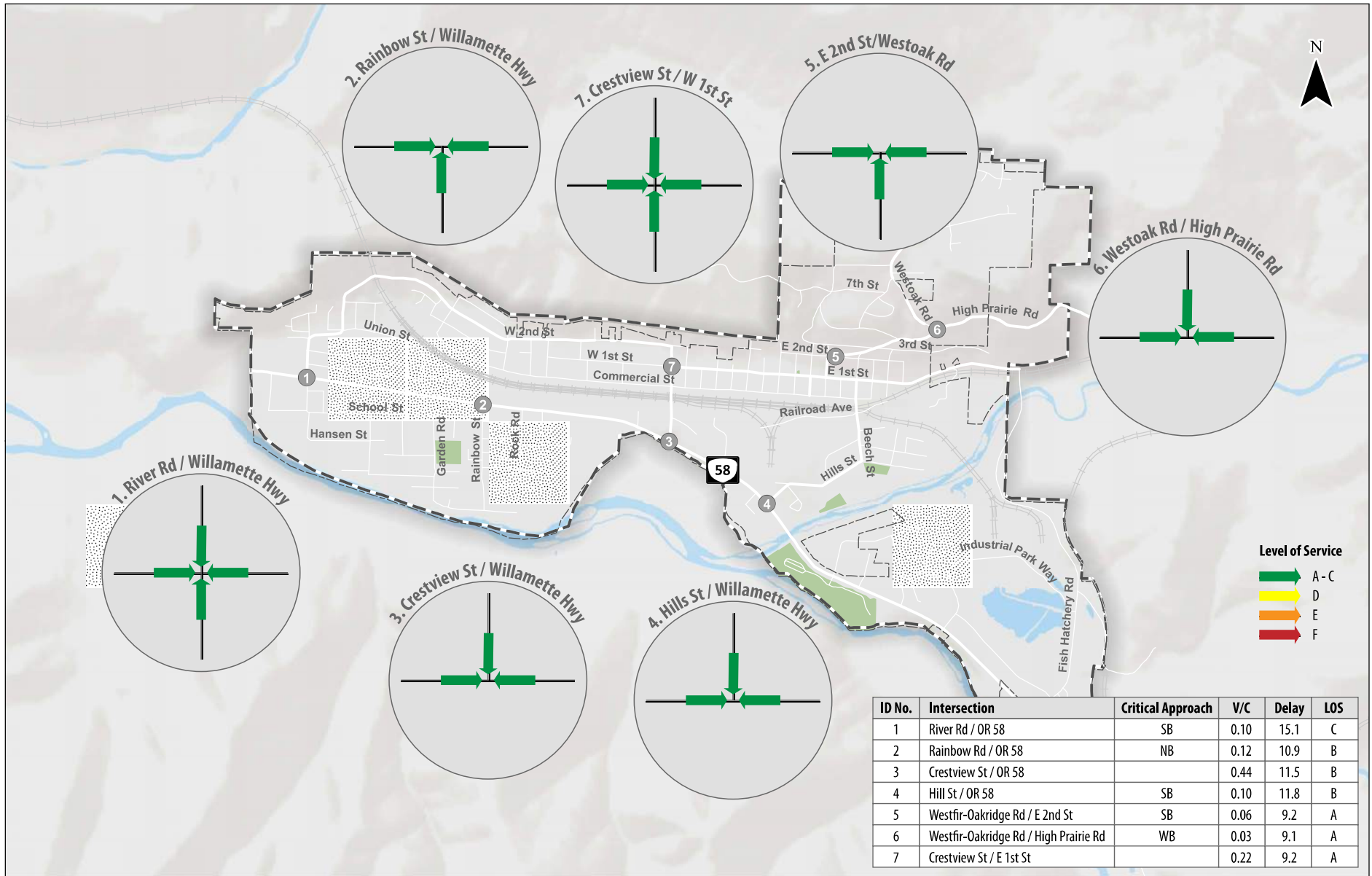

Future (2040) Peak Hour Intersection Operations  
Oakridge, Oregon

Figure  
**21**

H:\2020\2477 - Oakridge TSP Update\GIS\VolumeBaseMap.mxd - sfhyne - 3:21 PM 11/29/2018

## ROADWAY SEGMENT ANALYSIS

To help identify future needs along key corridors in the city, the existing volume-to-capacity ratios of four roadway segments was calculated. Seasonal adjustments were applied to the segments as described in the methodology memo. Table 10 summarizes the measured peak period traffic volumes, as recorded in July 2018, and the resultant volume-to-capacity ratio. As shown, this analysis revealed that all the segments operate well-below capacity.

**Table 10. Existing Roadway Segment Operational Analysis**

Map ID	Roadway	Location Description	ADT*	Peak Hour Volume*	PHF	Two-Way Demand Flow	Critical Flow Rate (vph)**	Calculated V/C Ratio
8	OR 58	Milepost 35.5 (east of Crestview St)	6570	550	0.90	611	2,500	0.24
9	OR 58	Milepost 35.4 (west of Crestview St)	9587	794	0.90	882	2,500	0.35
10	Beech Street	South of rail crossing	1308	111	0.90	123	1,000	0.12
11	Fish Hatchery Road	South of rail crossing	384	35	0.90	39	1,000	0.04

vph=vehicles per hour

\*Seasonally adjusted volumes

\*\*Critical flow rates were developed using the FDOT Generalized Annual Average Daily Volumes tables

(<http://www.fdot.gov/planning/systems/programs/SM/invisible/QLOS/Tampa/FDOT%202012%20Generalized%20Service%20Volume%20Tables.pdf>)

Table 11 shows the future 2040 segment volumes data using the growth rate factors provided in the methodology memorandum. As shown, all study segments are expected to operate below capacity in the future.

**Table 11. Future 2040 Roadway Segment Operational Analysis**

Map ID	Roadway	Location Description	ADT*	Peak Hour*	PHF	Two-Way Demand Flow	Critical Flow Rate (vph)**	Calculated V/C Ratio
8	OR 58	Milepost 35.5 (east of Crestview St)	8635	864	0.90	960	2,500	0.38
9	OR 58	Milepost 35.4 (west of Crestview St)	12600	1260	0.90	1400	2,500	0.56
10	Beech Street	South of rail crossing	1459	145.9	0.90	162	1,000	0.16
11	Fish Hatchery Road	South of rail crossing	429	42.9	0.90	48	1,000	0.05

vph=vehicles per hour

\*Seasonally adjusted volumes

\*\*Critical flow rates were developed using the FDOT Generalized Annual Average Daily Volumes tables

(<http://www.fdot.gov/planning/systems/programs/SM/invisible/QLOS/Tampa/FDOT%202012%20Generalized%20Service%20Volume%20Tables.pdf>)

## OR 58 TRAFFIC VOLUME AND SPEED

Volumes and speed profiles were developed to better understand the volume trends on OR 58. Figure 22 shows the hourly traffic volume profile for OR 58. As shown, traffic volumes are low during nighttime periods and increase during the day. Volumes remain fairly constant between 9:00AM and 4:00PM. This is likely due to the regional demand on OR 58 opposed to solely peak commuter periods.

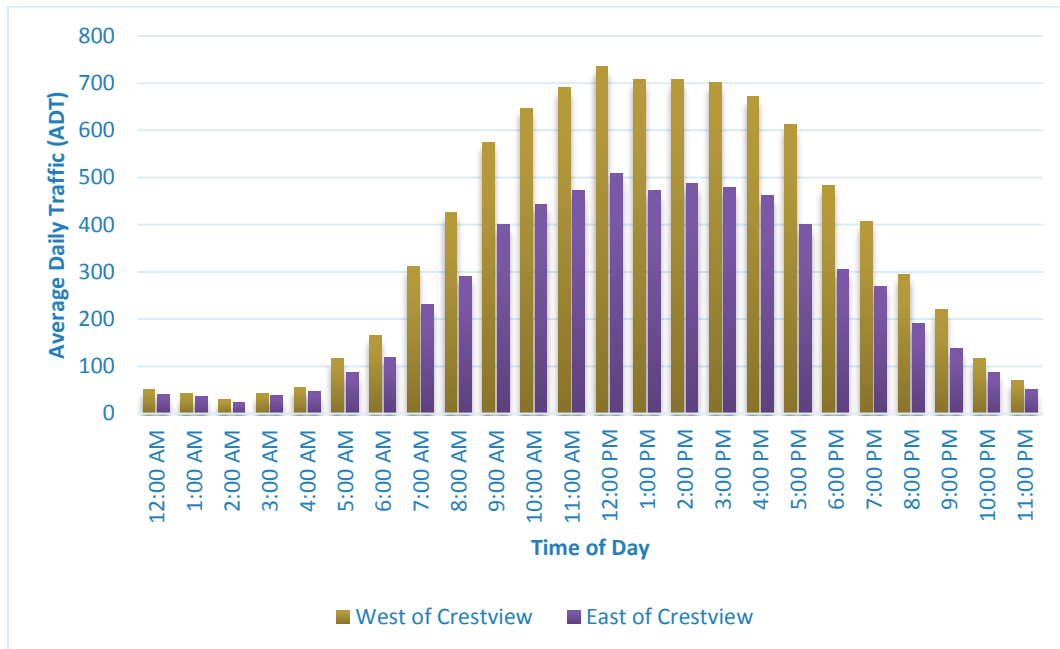

**Figure 22. Hourly Volume Profile for OR 58**

OR 58 is a 55 mile per hour roadway outside of City limits. However within the City, the speed is reduced to 35 miles per hour. Figure 23 shows a speed profile of OR 58 at Crestview Street. As shown, the majority of vehicles are traveling between 30 and 45 miles per hour through the intersection with the highest frequency of vehicles traveling five miles per hour above the posted speed. The 85<sup>th</sup> percentile speed was 39 miles per hour for westbound vehicles and 41 miles per hour for eastbound vehicles.

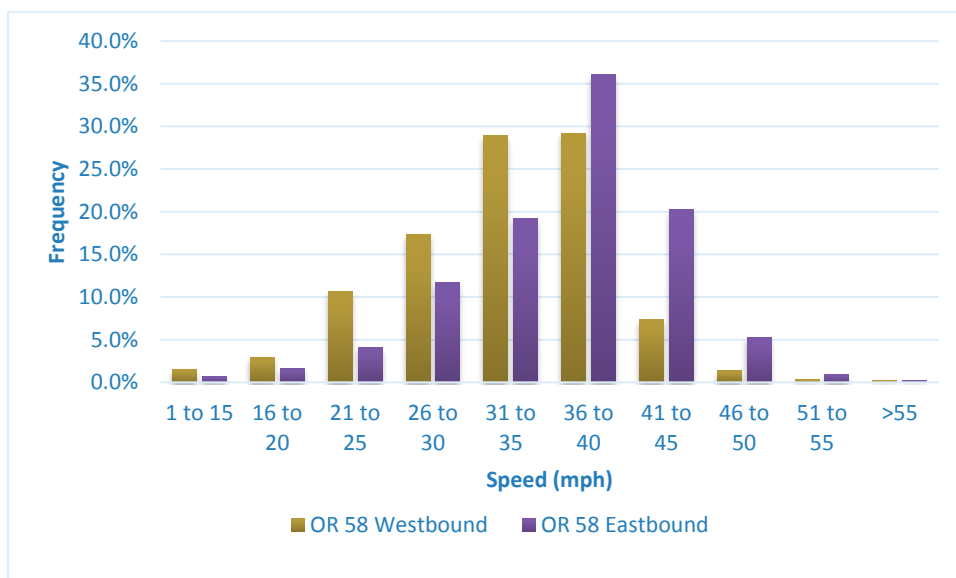

**Figure 23. Speed Profile for OR 58**

## INTERSECTION AND STREET OPERATIONS NEEDS

Based on the operations analysis completed for the existing and future conditions, the following needs were identified:

- ▶ Vehicle travel speeds on OR 58 within the city limits exceed the posted speed limit by 4 to 6 mph.

# 04 | HISTORIC CRASH DATA ANALYSIS

## HISTORIC CRASH DATA

A crash analysis was conducted for Oakridge to identify existing safety issues that could be addressed as part of the TSP update. The crash analysis includes a review and summary of reported crash data obtained from ODOT for the five-year period from January 1, 2012 through December 31, 2016. This includes the most complete five years of data available at the time of analysis. The data includes the location, type, and severity of all crashes that occurred along City, County and ODOT facilities within City limits.

### CITY CRASH PATTERNS

A total of 42 crashes were reported within the Oakridge UGB between 2012 and 2016. Table 11 summarizes the reported crashes by severity. There was one reported fatality during the study period. Forty-five percent of the crashes resulted in a fatality or injury. Figure 24 shows a map of the citywide crash locations based on severity. Over half of the citywide crashes occurred on either OR 58 or E 1<sup>st</sup> Street. Only two reported crashes occurred south of OR 58.

**Table 11. Citywide Crash Severity (2012-2016)**

	Crash Severity					
	Fatal	Injury A	Injury B	Injury C	PDO	Total
Number of Reported Crashes	1	0	7	11	23	42
Percent of Total Crashes	2%	0%	17%	26%	55%	100%

H:\2222477 - Oakridge TSP Update\GIS\Memo 4 - System Conditions and Deficiencies\Figure 24 - Crash Severity.mxd - jsomerville - 9:19 AM 1/4/2019

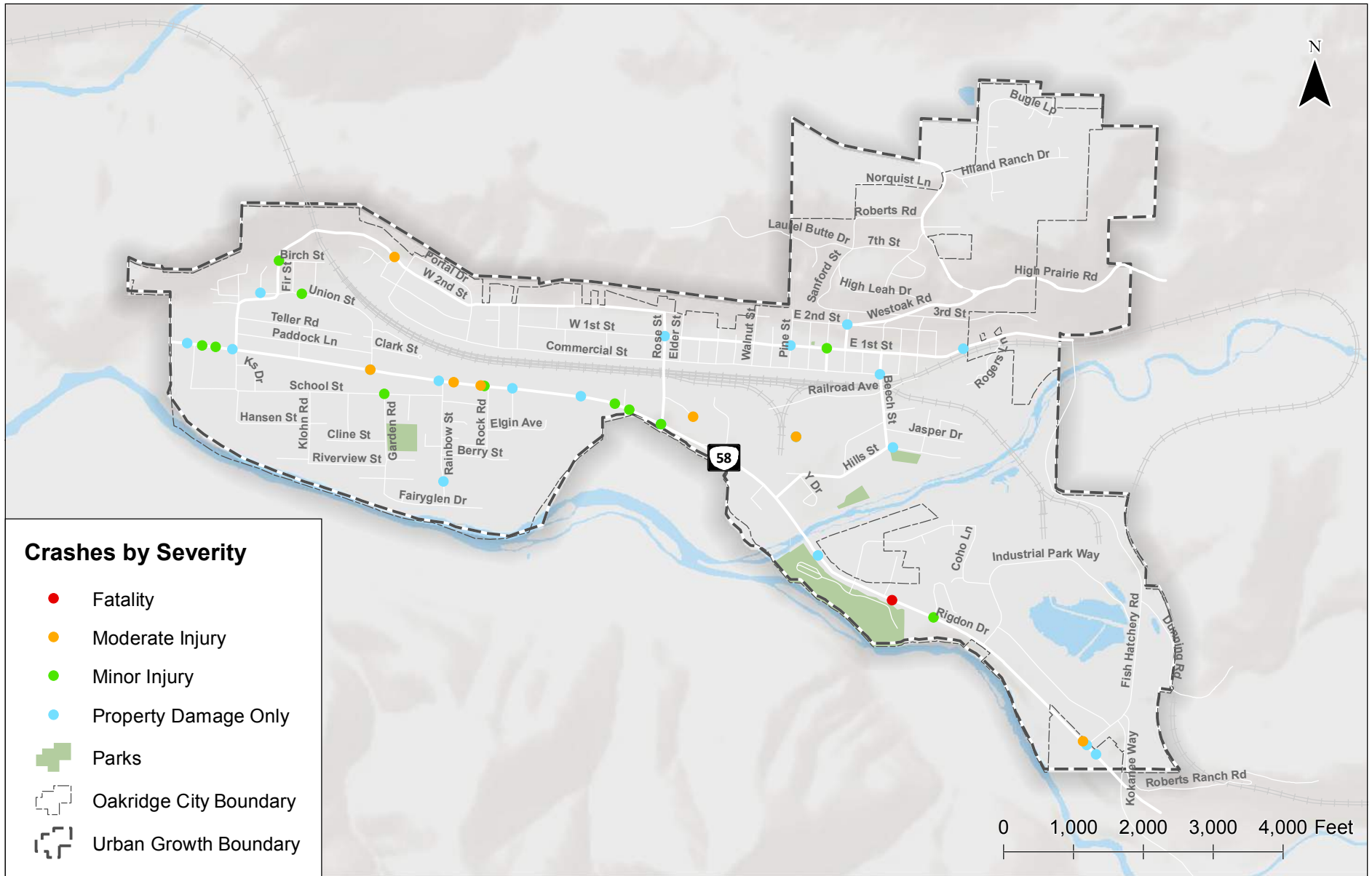

**Crash Severity of Crashes Reported in City Limits (2012 to 2016)  
Oakridge, Oregon**

**Figure  
24**

Figure 25 shows a summary of the reported crash types. Fixed-object, rear-end, and turning movement crashes account for 82 percent of crashes. Figure 26 shows the location of crashes based on crash type. All of the pedestrian and bicycle reported crashes occurred on OR 58. Additionally, a high proportion of turning movement collisions occurred on OR 58.

A summary of Citywide crash patterns is as follows:

- ▶ Fixed-object, rear-end, and turning movement crashes accounted for thirty-five crashes (83 percent of all crash types.) Of the thirty-five crashes, fourteen resulted in a fatality or injury.
- ▶ All reported bicycle and pedestrian related crashes resulted in injury.
- ▶ Alcohol was not indicated as a factor in any of the reported crashes, and drugs were indicated as a factor in one reported crash.
- ▶ At least 20 crashes (48 percent of all crashes in the UGB) occurred on OR 58.
- ▶ Thirty-one (74 percent) crashes occurred during daylight conditions.
- ▶ Twenty-eight (67 percent) crashes were reported on dry roadway conditions.
- ▶ No identifiable crash trends associated with year, month, or day of the week.

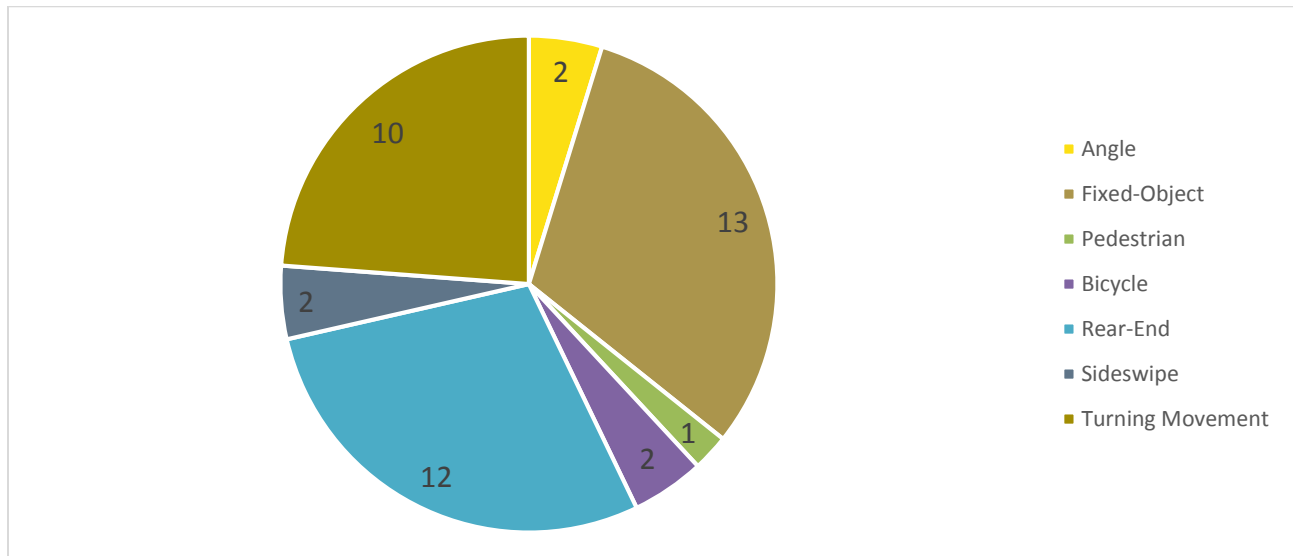

**Figure 25.** Citywide Crash Type (2012-2016)

H:\22\2477 - Oakridge TSP Update\GIS\Memo 4 - System Conditions and Deficiencies\Figure 26 - Collision Types.mxd - j.sommerville - 11:06 AM 1/4/2019

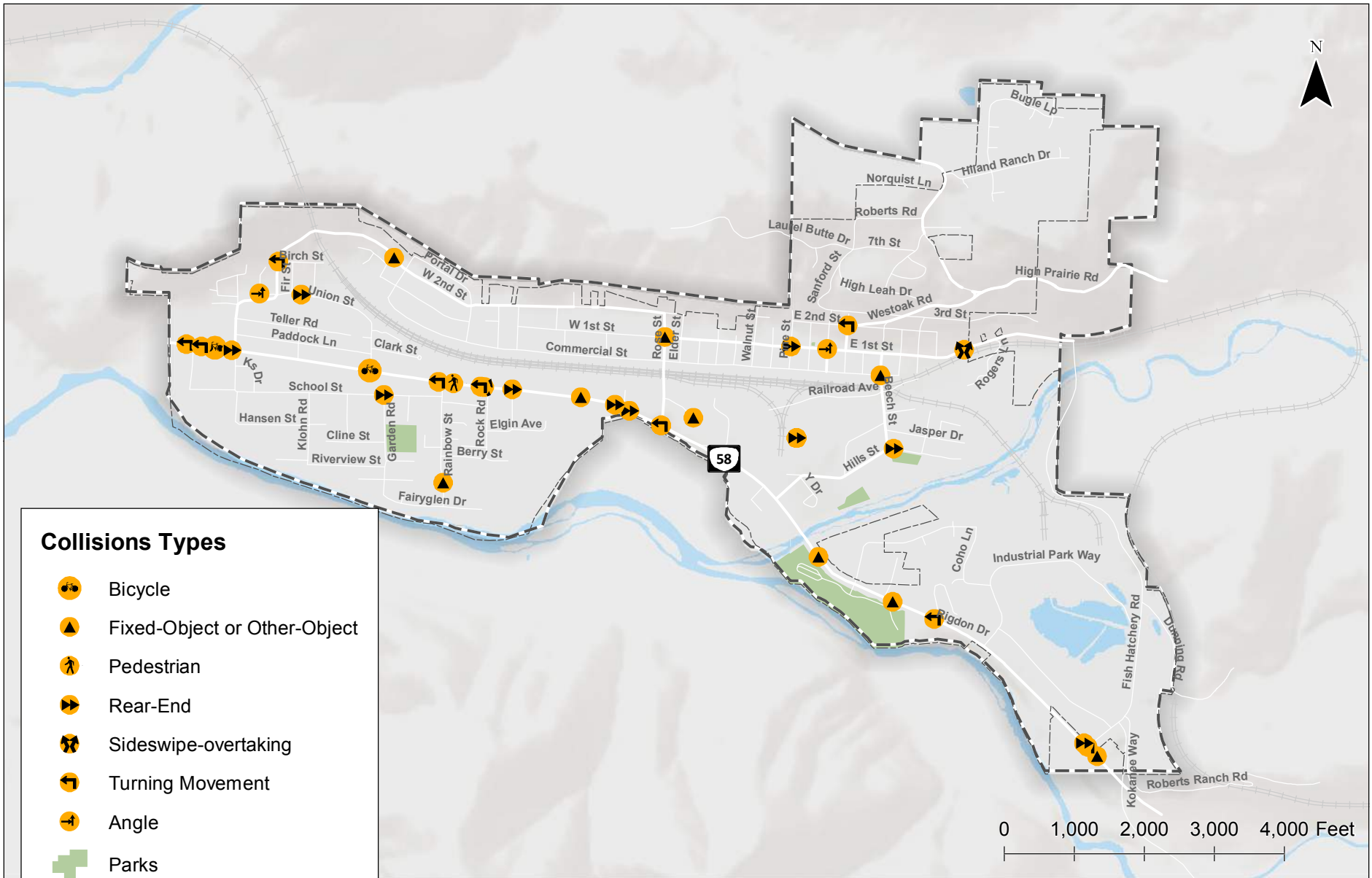

**Collision Types of Reported Crashes in City Limits (2012-2016)  
Oakridge, Oregon**

**Figure  
26**

## Fatal and Severe Crash Discussion

One fatal crash occurred in Oakridge on December 5<sup>th</sup>, 2015<sup>4</sup>. The crash was a run-off the road, fixed-object collision with a tree that involved a vehicle traveling west on OR 58 just south of Odle Lane. The crash occurred during the day in dry, clear conditions. The driver was the only occupant in the vehicle. The report indicates the crash was caused by improper driving. There were no reported severe injury crashes in the City between 2012 and 2013.

## Multimodal Crash Discussion

There were two reported bicycle crashes and one reported pedestrian crash that occurred during the study period. These crashes are described below:

- ▶ A pedestrian crash occurred on OR 58 east of Rainbow Road in September 2012. This crash occurred during dusk conditions. The crash reported indicated a crash cause of “non-motorist illegally in the roadway.” The crash resulted in moderate injuries. A Rectangular Rapid Flash Beacon (RRFB) has since been installed near the site of the crash.
- ▶ A bicycle crash occurred west of River Road on OR 58 in August 2013. The cyclist and vehicle collided as the driver turned right from a parking lot, heading westbound. The cyclist was riding eastbound (against traffic) on the sidewalk during clear, daytime conditions. A minor injury was reported.
- ▶ A bicycle crash occurred at the intersection of OR 58/Union Street in November 2014. The crash occurred during nighttime conditions and the cyclist was cited for illegally being in the roadway and not wearing visible clothing. The cyclist was traveling eastbound (against traffic), and the vehicle was making a southbound right-turn to head west. Drugs were identified as a contributing factor in the collision. The crash resulted in moderate injuries.

## STUDY INTERSECTION SUMMARIES

Table 12 provides a summary of study intersection crashes including collision type and severity. There were no fatal crashes at the study intersections between 2012 and 2016.

Table 12. Study Intersection Crash Summary (2012-2016)							
Intersection	Collision Type				Severity		
	Rear-End	Turning Movement	Fixed Object	Pedestrian	PDO	Injury	Total
River Road/OR 58	1	0	0	0	1	0	1
Rainbow Road/OR 58	0	1	0	1	1	1	2
Crestview Street/OR 58	0	2	1	0	2	1	3
Hill Street/OR 58	0	0	0	0	0	0	0
Westfir-Oakridge Road/E 2nd Street	0	1	0	0	1	0	1
Westfir-Oakridge Road/High Prairie Road	0	0	0	0	0	0	0
Crestview Street/E 1st Street	0	0	1	0	1	0	1
<b>Total</b>	<b>1</b>	<b>4</b>	<b>2</b>	<b>1</b>	<b>6</b>	<b>2</b>	<b>8</b>

<sup>4</sup> It is noted that a bicycle related crash occurred on Highway 58 in the summer of 2017



The following is a summary of the crashes that occurred at study intersections between 2012 and 2016:

- ▶ OR 58/River Road/W 2nd Street
  - A night-time rear-end crash occurred in December 2013.
  - The crash occurred between a moving vehicle and a parked car during snowy conditions.
  - The crash resulted in property damage only.
- ▶ OR 58/Rainbow Road
  - A turning movement and pedestrian crash occurred at this intersection (details about the pedestrian crash are described above).
  - The turning movement crash occurred during clear, daytime conditions and resulted in property damage only.
- ▶ OR 58/Crestview Street
  - There were three reported crashes at the signalized intersection: two turning movement and one fixed object crash.
  - The fixed object crash involved a power pole in the northeast quadrant of the intersection. The crash occurred during wet, nighttime conditions and resulted in property damage only.
  - Both turning movement crashes were caused by a driver not yielding to right-of-way. One crash resulted in minor injuries and the other resulted in property damage only.
- ▶ OR 58/Hills Street
  - There were no reported crashes at this intersection during the study period.
- ▶ E 2nd Street/Westfir-Oakridge Road
  - A daytime turning movement crash occurred in January 2015.
  - The crash resulted in property damage only.
- ▶ Westfir-Oakridge Road/High Prairie Road
  - There were no reported crashes at this intersection during the study period.
- ▶ Crestview Street/1<sup>st</sup> Street
  - A fixed-object crash occurred in November 2012.
  - The vehicle hit a stop sign or yield sign at the intersection.
  - The crash resulted in property damage only.

## Statewide Crash Performance Standards

The state has identified several safety performance standards. Table 13 provides a summary of the intersection crash rates compared to the state performance standards of critical crash rate and 90<sup>th</sup> percentile crash rate. The intersection crash rate was calculated based on the peak hour intersection turning movement counts. The peak hour was assumed to be ten percent of the daily volume. These performance standards are further described in this section.

**Table 13. Citywide Crash Severity (2012-2016)**

Intersection	Total Crashes (2012-2016)	Critical Crash Rate*	90 <sup>th</sup> Percentile Crash Rate*	Observed Crash Rate	Observed Crash Rate Exceeds Critical or 90 <sup>th</sup> Percentile Crash Rate?
River Road/OR 58	1	0.45	0.408	0.09	No
Rainbow Road/OR 58	2	0.33	0.293	0.14	No
Crestview Street/OR 58	3	0.55	0.509	0.22	No
Hill Street/OR 58	0	0.38	0.293	0.00	No
Westfir-Oakridge Road/E 2nd Street	1	0.76	0.293	0.46	<b>Yes</b>
Westfir-Oakridge Road/High Prairie Road	0	0.77	0.293	0.00	No
Crestview Street/E 1st Street	1	0.53	0.408	0.13	No

\*Crash rates indicate the number of crashes per million entering vehicles (MEV) at the intersection.

### 90<sup>th</sup> Percentile Crash Rate Comparison

The 90<sup>th</sup> percentile crash rate comparison is used to identify intersections with more crashes than expected (based on traffic volume) when comparing the crash rate to the statewide 90<sup>th</sup> percentile rates for similar intersection types, as documented in Table 4-1 of the ODOT APM. The intersection of Westfir-Oakridge Road/E 2<sup>nd</sup> Street exceeds the 90<sup>th</sup> percentile crash rate. One crash occurred at the intersection during the study period. However, the low daily traffic volume resulted in a higher calculated crash rate.

### Critical Crash Rate Comparison

A critical crash rate may be used to identify intersections that warrant further investigation and may represent opportunities to reduce crash frequency and severity. The critical crash rate establishes a threshold for comparison among intersections with similar number of approaches and similar traffic control. *Appendix F includes the Critical Crash Rate data as provided by ODOT and defined in Chapter 4 of the ODOT APM. None of the study intersections exceed the critical crash rate.*

### Statewide Priority System (SPIS)

The ODOT Statewide Safety Priority Index System (SPIS) identifies sites along state highways where safety issues warrant further investigation. The SPIS is a method developed by ODOT for identifying potential safety issue locations on state highways through consideration of crash frequency, crash rate, and crash severity. There are no locations in the City of Oakridge that are above the 85 percentile SPIS threshold.

---

## COMMUNITY SAFETY CONCERNS

---

Throughout any community, there are safety concerns that may not be identifiable through crash data analysis. During a public process, community members were asked to identify intersections, segments, or areas in Oakridge where they have observed a safety concern. The following is a list of locations and concerns:

- ▶ Union Street/OR 58:
  - Union Street approaches OR 58 on a downgrade and intersects with OR 58 at the bottom of the hill. Union Street is heavily used by bicyclists and pedestrians. There are no advanced intersection warnings for southbound vehicles at the intersection.

- ▶ Westoak Road/High Prairie Road
  - The intersection has challenging geometry and is stop controlled at the southwestbound movement. The steep hills and unique intersection control make this intersection challenging to drivers. It is unclear which eastbound movement has the right-of-way.
- ▶ Industrial Way/OR 58
  - Industrial Way intersects the highway where the eastbound left lane, which is used as a passing lane, ends. This results in vehicles speeding up, attempting to complete a passing movement, in the same lane where vehicles stop to wait to complete an eastbound left-turn movement. This results in potential conflicts between the two movements.
- ▶ Hill Street Sight Distance
  - Trucks are often parked on the east corner of Hills Street/OR 58. This restricts sight distance for southbound vehicles and requires vehicles to encroach into the intersection.
- ▶ Uptown Parking
  - There is angled parking along both sides of the road in the Uptown Area on E 1<sup>st</sup> Street. Community members noted difficulty for drivers backing out of parking spots as well as challenges for drivers on E 1<sup>st</sup> Street to see and react to drivers backing out of parking spaces.
- ▶ Westbound Merge Lane
  - On the westside of town, westbound vehicles accelerate before the merge lane. As shown in Figure 26, there have been several crashes on the highway on the western-most part of town.
- ▶ Greenwaters Park/OR 58
  - The park is located near city limits on the east side of Oakridge. This is an area where vehicles are transitioning from a rural highway to an urbanized area. Therefore, the posted speed limit is higher here than in the core of Oakridge. It is challenging to perform northbound left and southbound left turning movements onto the highway.

---

## SAFETY NEEDS

---

This section summarizes the safety needs identified through the safety analysis:

- ▶ The three reported pedestrian and bicycle crashes within the City occurred on OR 58. OR 58 has limited facilities available for travel along and across the highway. This will be further discussed in the Alternative Transportation Analysis section of the memo.
- ▶ Several intersection and segment safety concerns were identified by the community. These locations will be further analyzed to determine risk factors and potential improvements.

## 05 | ALTERNATIVE TRANSPORTATION ANALYSIS

The following section identifies the existing transportation conditions for the pedestrian, bicyclist, transit, rail, and air systems.

---

### PEDESTRIAN AND BICYCLE SYSTEM

---

The City's sidewalk, bike lane, and trail system support a healthy and equitable community that continues to prosper economically. Area residents use the multimodal system for recreation as well as to provide access to several parks,

community facilities, schools, and businesses. Figure 27 illustrates the location of sidewalks, bike lanes, and trails within the City, which are discussed below.

- ▶ Continuous east-west or north-south sidewalk systems are generally located along E 1<sup>st</sup> Street between the Uptown area and the schools, along Commercial Street, along Crestview Street, along Hills Street, and along School Street in the residential area of southeast Oakridge. The sidewalks present along E 1<sup>st</sup> Street provide access to many key activity centers including city hall, the schools, and the library.
- ▶ OR 58 has continuous sidewalks available on the north side of the highway west of Rainbow Street. East of Rainbow Street, OR 58 does not have pedestrian facilities. Therefore, there are no east-west continuous pedestrian facilities extending through the entire City.
- ▶ In addition, gaps in the sidewalk system are noted on collector and arterial roads including W 2<sup>nd</sup> Street, Westoak Road, and W 1<sup>st</sup> Street. The local sidewalk system is largely incomplete in most areas of the City including the residential areas in the southwest and northeast areas of the City.
- ▶ There are two grade separated pedestrian crossings of the railroad in Oakridge:
  - W 2<sup>nd</sup> Street travels over a railroad tunnel on the west end of the City.
  - Crestview Street crosses over the railroad just north of OR 58.
- ▶ Pedestrians and bicyclists have been observed crossing the railroad at an unmarked dirt path between Union Road and Commercial Street. This may be due to a lack of direct grade separated railroad crossings in this area of the City.
- ▶ There are limited dedicated bike facilities throughout the City, with bicycle lanes present on sections of E 2<sup>nd</sup> Street, Crestview Street, and Rainbow Street. Bicyclists share the road when there is no bicycle lane or shoulder provided. Although bicyclists may be of any age or ability, only the more confident, experienced riders are likely to be comfortable sharing the road with vehicles on higher-speed facilities. On the higher speed facilities, including OR 58, dedicated facilities and space for cyclists are needed.
- ▶ Many intersections on 1<sup>st</sup> Street have marked crosswalks. However, there are a lack of marked crosswalks through the remainder of the City. A Rectangular Rapid Flashing Beacon (RRFB) was installed on OR 58 west of Rock Road in early 2018. This is near the location where a pedestrian related crash occurred in 2012. The only other marked pedestrian crossing of OR 58 is located at the signalized intersection of OR 58/Crestview Street. However, the pedestrian crossing at this location leads to a cliff; there is no sidewalk available on the south side of the highway, as shown in the photo below.



Illustration of existing crosswalk at OR 58/Crestview Street that lacks a sidewalk or shoulder for pedestrians on the south side of OR 58.

H:\2202477 - Oakridge TSP Update\GIS\Memo 4 - System Conditions and Deficiencies\Figure 27 - Bicycle and Pedestrian Facilities.mxd - atudwig - 2:29 PM 12/14/2018

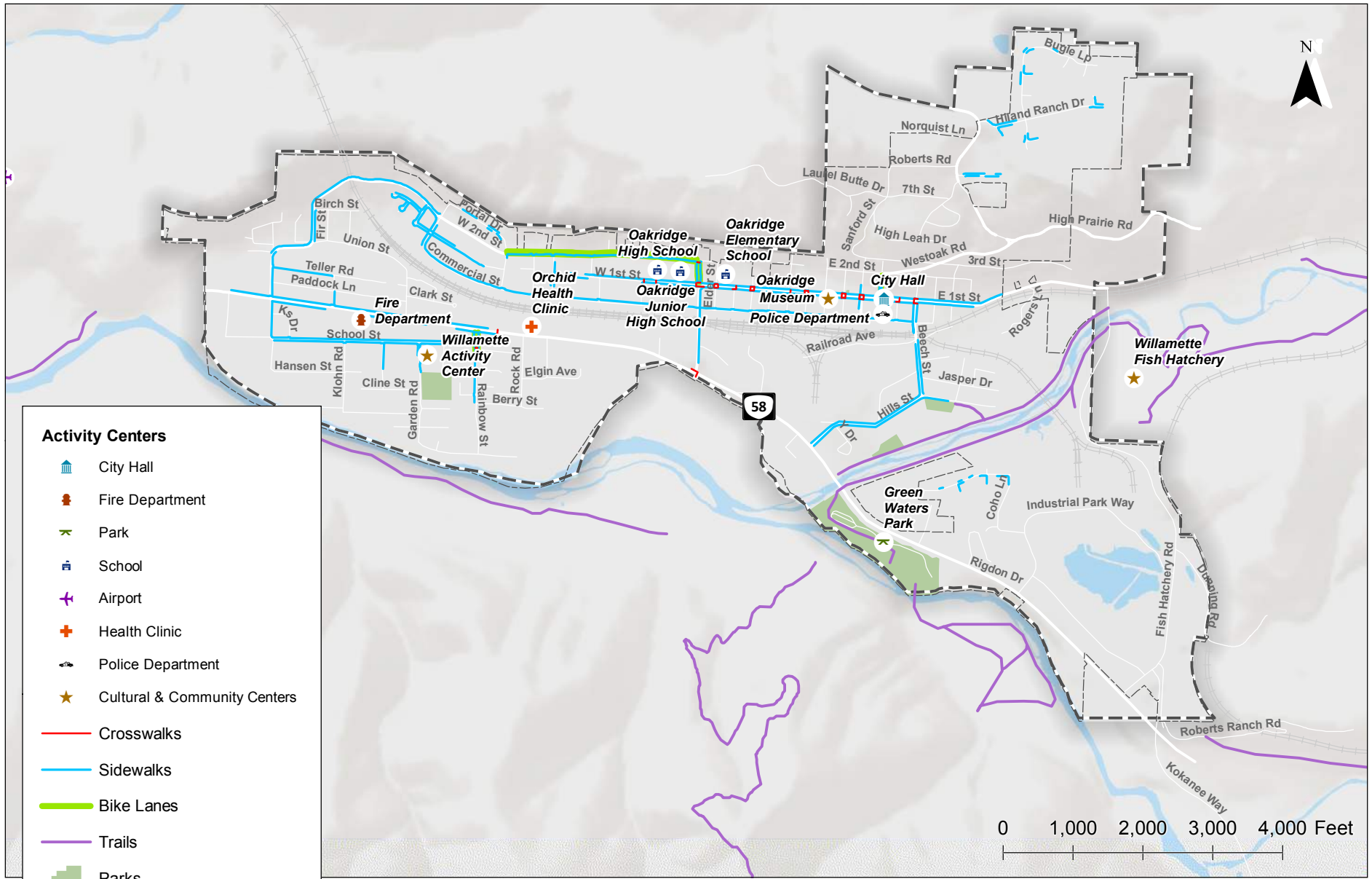

**Bicycle and Pedestrian Facilities  
Oakridge, Oregon**

**Figure  
27**

## RECREATIONAL ACTIVITIES

Oakridge is world renown for mountain biking, attracting many visitors who come to Oakridge to ride their trails. Strava data was used to capture a snapshot of some routes that riders are using within and around the City. Figure 28 shows a heat map of the locations cyclists are using the Strava application to track their ride. Strava is a website and mobile application that allows bicyclists to self track their rides. Strava stores and compiles the information provided by users. This information can be used to indicate relative usage of roadways among Strava application users. For example, high usage roadways are those that are traveled by many cyclists using the Strava application. Although it is not representative of all bicyclists (those without the Strava application are not represented) and does not indicate the comfort level of the bicyclists on the roadway, Strava data illustrates some of the common routes used by riders.

High frequency routes are shown by the bright yellow and low frequency routes are purple and grey. As shown, the primary routes by Strava users within the City limits include OR 58, Fish Hatchery Road, Crestview Street, E 1<sup>st</sup> Street, Salmon Creek Road, and Westoak Road. Other routes with moderate ridership include W 2<sup>nd</sup> Street, Hill Street, and Commercial Street.

There are three primary routes to access mountain biking trails from the City:

- ▶ Larison Rock Trail: This route is shown by the bright yellow trail south of the City. Users may access the trail through Green Waters Park. The route from the trail into the City requires cyclists to ride on OR 58. There are no dedicated bike lanes on OR 58.
- ▶ A-T-C-A and North Fork: These trails are located north of the City of Westfir. This trail can be accessed from Oakridge by ways of Westoak Road. There are no multimodal facilities north of the Westoak Road/E 2<sup>nd</sup> Street intersection. Cyclists must ride within the travel lane on windy roads where visibility of cyclists for approaching vehicles may be limited.
- ▶ Dead Mountain and Salmon Creek: These trails are accessed via Fish Hatchery Road and Salmon Creek Road. There are two trails shadowing Salmon Creek on of eastside of the City. There are no other multimodal facilities one these roadways.
  - The Salmon Creek trail was identified in the 2000 Oakridge TSP for a paving project. This was a medium-priority project and since the adoption of the TSP, several segments of the trail have been upgraded, however, the majority of the trail is maintained as a dirt trail.

There are several substantial gaps for recreational mountain bikers and trail users within the City's system that are highlighted by the Strava data. Providing more biking connections and wayfinding to trails and connections could improve mobility, promoting economic development for the City and mountain biking community.

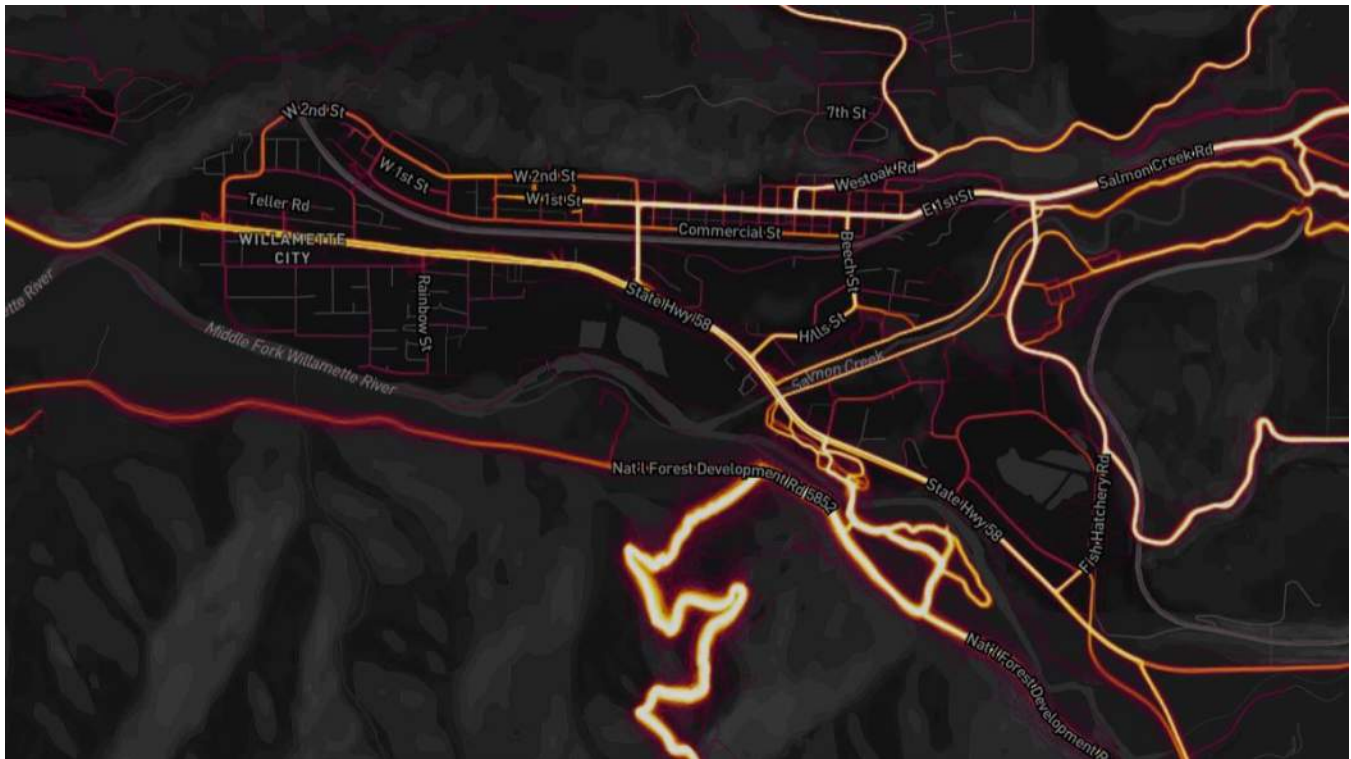

**Figure 28.** Oakridge Strava Heat Map (source: Strava, <https://www.strava.com/heatmap#14.02/-122.47684/43.74367/hot/all>)

## OR 58 CORRIDOR

The OR 58 corridor is an important east-west corridor within the City of Oakridge. It provides one of the few complete east-west routes through town. However, OR 58 lacks a complete system of sidewalk, bicycle lanes, and crossing opportunities, which creates a barrier to both east-west and north-south multimodal traffic. As documented in Figure 27, only two pedestrian crossings of OR 58 are provided, with one leading to no sidewalk facilities on the south side of OR 58.

Traffic counts conducted at the four study intersections along OR 58 during the p.m. peak hour (4:00 – 5:00 pm), showed the following pedestrian and bicycle volumes at the intersections:

- ▶ OR 58/River Road/W 2<sup>nd</sup> Street: Two pedestrians crossed OR 58 on the east leg of the intersection. One bicyclist crossed OR 58 northbound, and one bicyclist crossed OR 58 southbound.
- ▶ OR 58/Rainbow Road: No pedestrians or bicyclists observed.
- ▶ OR 58/Crestview Street: Two pedestrians crossed the north leg of the intersection. One bicyclist traveled eastbound through the intersection, and one bicyclist made a southbound right turn.
- ▶ OR 58/Hills Street: One pedestrian crossed the north leg of the intersection, and two pedestrians crossed OR 58 on the east leg of the intersection. One bicyclist traveled through the intersection going eastbound.

As documented in previous sections of this memorandum, the 85<sup>th</sup> percentile travel speed on OR 58 is 39 mph in the eastbound direction and 41 mph in the westbound direction. As noted in the operations analysis, the peak hour volume on OR 58 varies from approximately 550 vehicles per hour (vph) to 800 vph, depending on the location within the City. The traffic volumes on OR 58 were higher west of Crestview Street.

OR 58 is a five-lane facility on the west end of the City, with a total width of approximately 60 feet. The MUTCD recommends a normal walking speed of 1.2 meters/second (4 feet/second) for calculating pedestrian interval length at signals. However, walking speed is influenced by age; older users may have slower walking speeds. Assuming a walking speed of 4 ft/sec, a pedestrian would take 15 seconds to cross OR 58. This is a substantial amount of time, and pedestrians may struggle to find the necessary gap in traffic. The RRFB installed across OR 58 west of Rock Road is illustrated in the image below. This improvement provides an activated beacon to warn drivers of crossing pedestrians and a pedestrian refuge island to reduce the crossing distance by allowing the pedestrian to cross in two-stages.

A previous study was completed in 2016 focusing on multimodal accommodations on OR 58 within the City. The results of this study are further discussed below.



Illustration of Pedestrian Crossing with RRFBs Installed on OR 58, West of Rock Road

## Oakridge Pedestrian Safety Study (2016)

The Oakridge Pedestrian Safety Study, completed by DKS Associates in February 2016, is intended to improve safety for all modes of travel along the OR 58 corridor in Oakridge, with the primary emphasis to provide safe pedestrian and bicycle crossing locations along the highway. The study, which consisted of both a public involvement component and a technical analysis component, resulted in a toolbox of pedestrian crossing treatments and a compilation of recommended safety projects along OR 58 to improve pedestrian and bicycle safety (Chapter 3, Crossing Treatment Toolbox). Crossing improvement concepts were developed for the following five locations along OR 58 and are summarized in Table 14.



**Table 14. Conceptual Crossing Improvements on OR 58**

Rank	Crossing Locations	Priority	Description of Proposed Treatment
1	Rock Road to Jones Road <sup>a</sup>	Short-term	RRFB (Complete)
2	West of River Road	Short-term	Raised median, curb extensions, traffic calming, lighting, sidewalk
3	Rainbow Road	Mid-term <sup>b</sup>	Lighting only
4	Hills Street	Mid-term	Raised median, curb extensions, traffic calming, lighting, sidewalk
5	Union Street	Mid-term	Raised median, curb extensions, traffic calming, lighting, sidewalk
A <sup>b</sup>	East of Jones Road	TBD <sup>c</sup>	RRFB, sidewalk, and lighting
N/A <sup>d</sup>	OR 58/Crestview Street Traffic Signal	N/A	Supplementary lighting, pedestrian countdown timers, and sidewalk infill.

<sup>a</sup> This project has been completed (after the 2016 study was complete) with a RRFB installed approximately 325 west of Rock Road, between Rainbow Road and Rock Road.

<sup>b</sup> Crossing location was added to the study’s recommendations based on public input.

<sup>c</sup> Crossing location will be a short-term priority when construction of a pedestrian bridge/community center occurs.

<sup>d</sup> The signalized intersection of OR 58/Crestview Street was not prioritized relative to the unsignalized crossing locations in the Study.

The study states that for the highest priority location for a pedestrian crossing of OR 58 was between Rock Road and Jones Road. A RRFB with a pedestrian refuge island was constructed on OR 58 approximately 325 west of Rock Road in early 2018. It is the only marked pedestrian crossing on OR 58 west of Crestview Street. In addition, a secondary crossing location with RRFBs is recommended east of Jones Road based on the City’s future plans to construct a community center and pedestrian bridge near this location. Due to the four-lane cross-section, a pedestrian refuge island is not recommended in the Study at this location.

As a second priority project, the study recommends that a raised median, curb extension, or other traffic calming improvement should be made along with sidewalk in fill along the south side of OR 58 west of River Road. Crossing treatment recommendations at the other locations do not include RRFBs. The recommendation at Rainbow Road calls for lighting only due to the proximity to the recently installed RRFB. A prioritized project list and cost estimates for each of the crossing improvement locations and signalized improvement locations can be found in Chapter 6, Project Implementation.

Corridor-wide safety treatments—including street lighting, speed feedback signs, and lane conversions—were also considered along the entire length of the study area. No specific locations were identified for access management, with the exception of the pedestrian crossing improvement locations. However, the study presents an option for a three-lane roadway conversion on OR 58 to increase corridor safety and in response to the surrounding land uses, available roadway width, collision analysis, and motor vehicle volumes. This alternative, including the need to obtain approval for any reductions in capacity on a freight route, is discussed in detail in Chapter 5: OR 58 Lane Conversion Alternative.

The TSP alternatives analysis will incorporate the recommendations from the 2016 Pedestrian Study. The recommendations will be reviewed and either incorporated as is or refined based on current data and the TSPs public involvement process.

## QUALITATIVE MULTIMODAL ANALYSIS

A qualitative multimodal analysis was conducted for both the existing pedestrian and bicycle network according to the ODOT Analysis and Procedures Manual Chapter 14 Section 3. This analysis was conducted for roadways classified as a collector or higher within Oakridge. A qualitative multimodal analysis examines and scores the characteristics of sidewalk and bicycle segments. The possible scores are Excellent, Good, Fair, and Poor. The scores were based on the inventory available, Bing Maps, and data provided by the City.

### Pedestrian Qualitative Analysis

The pedestrian qualitative analysis was based on the following criteria: sidewalk presence, sidewalk condition, sidewalk width, lighting, grade, buffer, and travel speed. Figure 29 shows the qualitative pedestrian ratings for collector, arterial, and highway roads throughout the City. There are several locations with excellent and good ratings particularly near the schools, Uptown area, and Willamette Activity Center. The majority of remaining roadways, including routes where students may walk to school, are in fair or poor condition. A *pedestrian qualitative analysis table is provided in Appendix G.*

### Bicycle Qualitative Analysis

The bicycle qualitative analysis was based on the following criteria: bike lane presence, shoulder presence, pavement condition, grade, on street parking, and travel lane speed. Figure 30 shows the ratings of bicycle facilities on collector, arterial, and highway roads. There are limited dedicated bicycle facilities throughout the city. This also results in lack of connections to key recreational trails throughout the greater Oakridge region. While shared roadways are typical of local streets, dedicated bicycle lanes provide connectivity throughout the community on high volume, high speed facilities such as collectors, arterials, and/or highways. With the anticipated economic, population, and traffic volume growth in the area, dedicated bicycle facilities should be prioritized within the city. A *bicycle qualitative analysis table is provided in Appendix H.*

H:\22\22477 - Oakridge TSP Updates\GIS\Memo 4 - System Conditions and Deficiencies\Figure 29 - Ped Qualitative Analysis.mxd - isomerville - 7:10 AM 1/2/2019

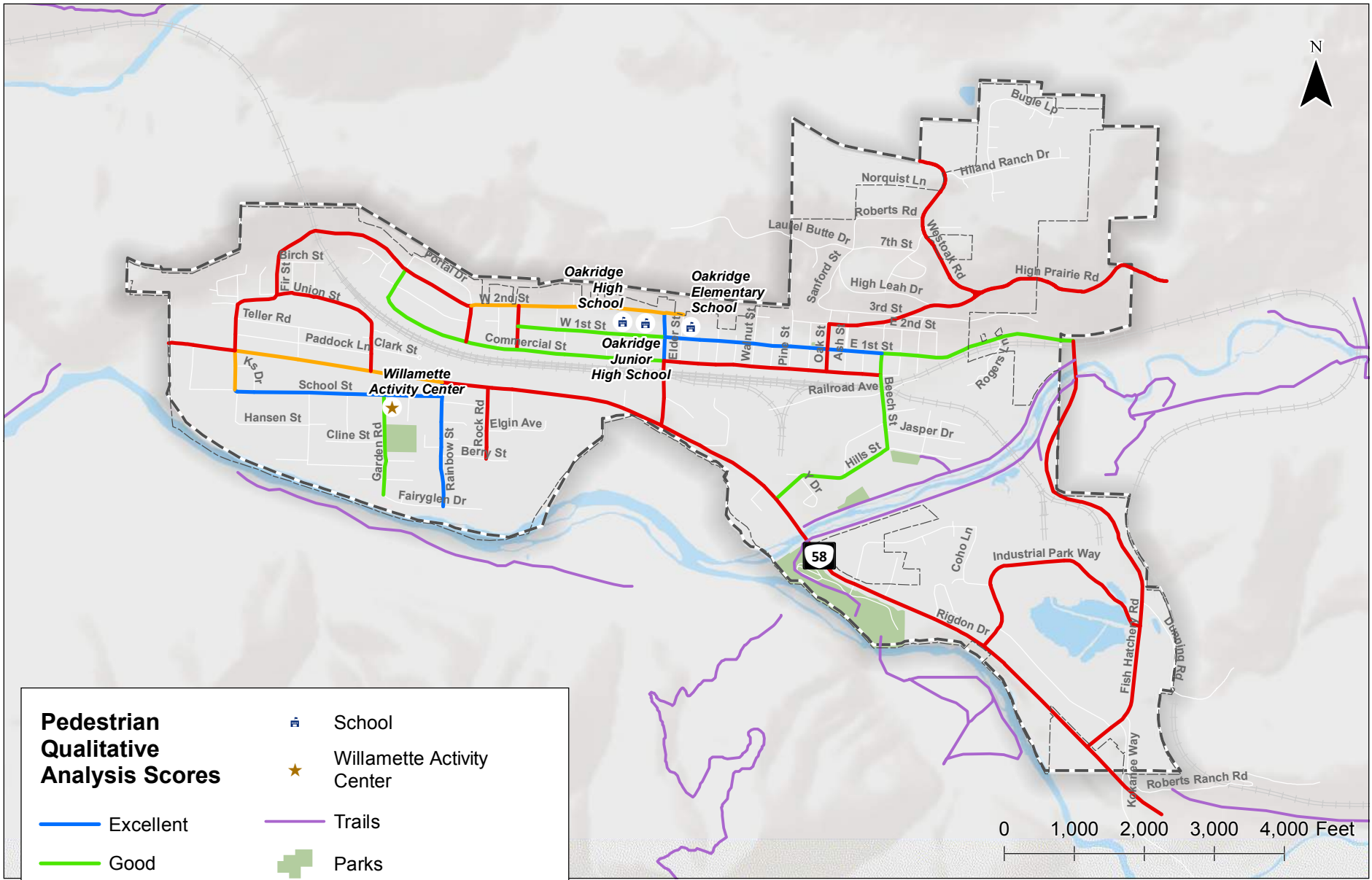

Pedestrian Qualitative Analysis Scores	
<span style="color: blue;">—</span> Excellent	School
<span style="color: green;">—</span> Good	Willamette Activity Center
<span style="color: orange;">—</span> Fair	Parks
<span style="color: red;">—</span> Poor	Oakridge City Boundary
	Urban Growth Boundary
	<span style="color: purple;">—</span> Trails

**Pedestrian Qualitative Analysis Scores  
Oakridge, Oregon**

**Figure  
29**

H:\22\22477 - Oakridge TSP Update\GIS\Memo 4 - System Conditions and Deficiencies\Figure 30 - Bike Qualitative Analysis.mxd - jbrnerville - 7:10 AM 1/22/2019

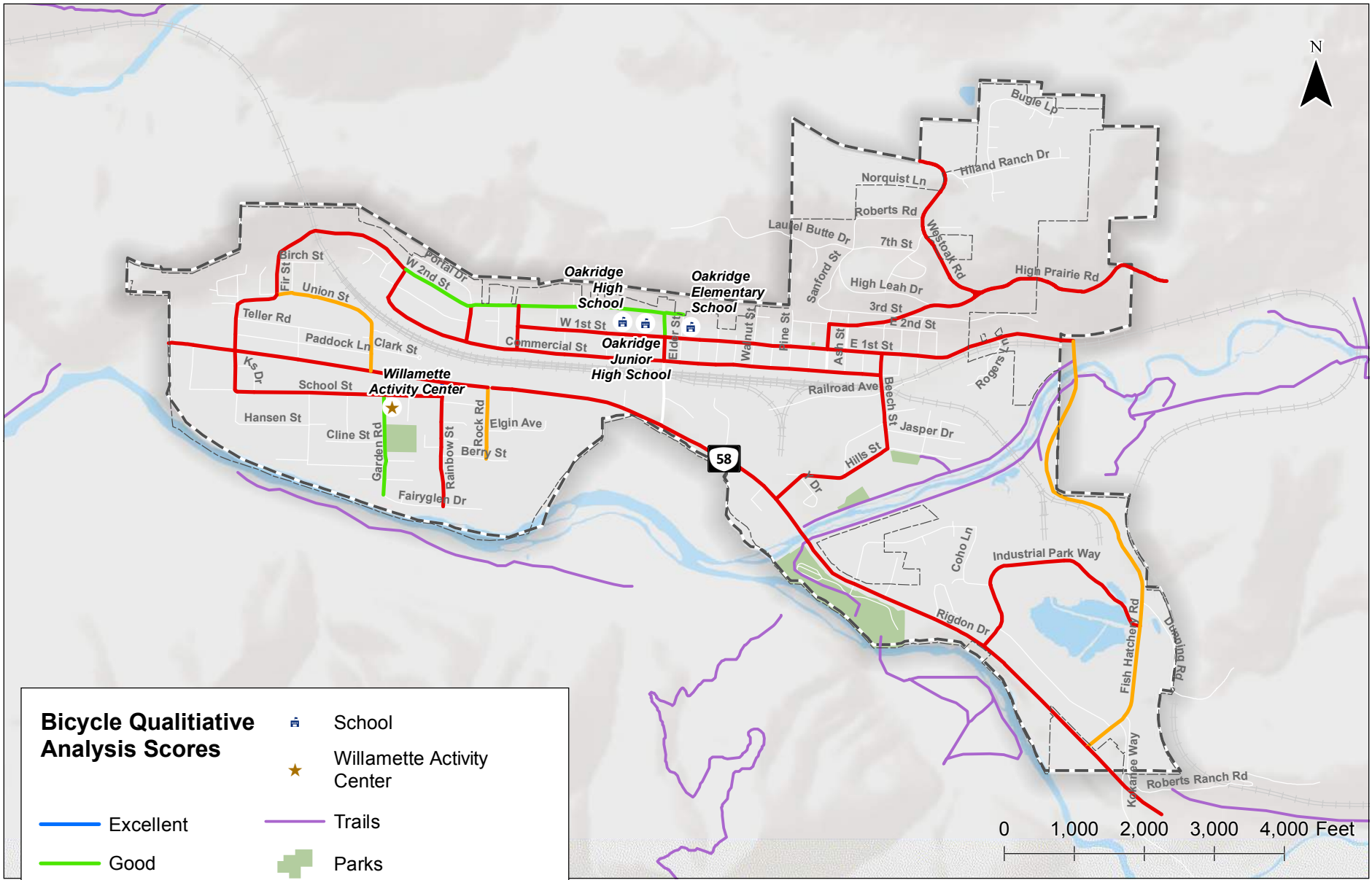

Bicycle Qualitative Analysis Scores	
<span style="color: blue;">—</span> Excellent	School
<span style="color: green;">—</span> Good	Willamette Activity Center
<span style="color: orange;">—</span> Fair	Parks
<span style="color: red;">—</span> Poor	Trails
	Oakridge City Boundary
	Urban Growth Boundary

**Bicycle Qualitative Analysis Scores  
Oakridge, Oregon**

**Figure  
30**

## PUBLIC TRANSIT SYSTEM

The Lane Transit District (LTD) provides public transportation to Oakridge via a fixed route call the "Diamond Express". The Diamond express provides service from Eugene to the cities of Oakridge and Westfir. The Diamond Express route is funded through grants provided by the Intercity Passenger Program. This program was created to provide rural communities connections to medical services, shopping, schools, and jobs in a larger metropolitan area.

Figure 31 shows a map of the services provided on this route. Within Oakridge, riders may request to board or get off at any location on the route with the exception of stopping on OR 58. Outside of Oakridge the bus only stops where riders ask to get off or at designated bus stop locations. Table 15 reports the service schedule for the Diamond Express route. This route only operates during the weekday – there are no services available on the weekends. The weekday service includes three trips – morning, afternoon, and evening.

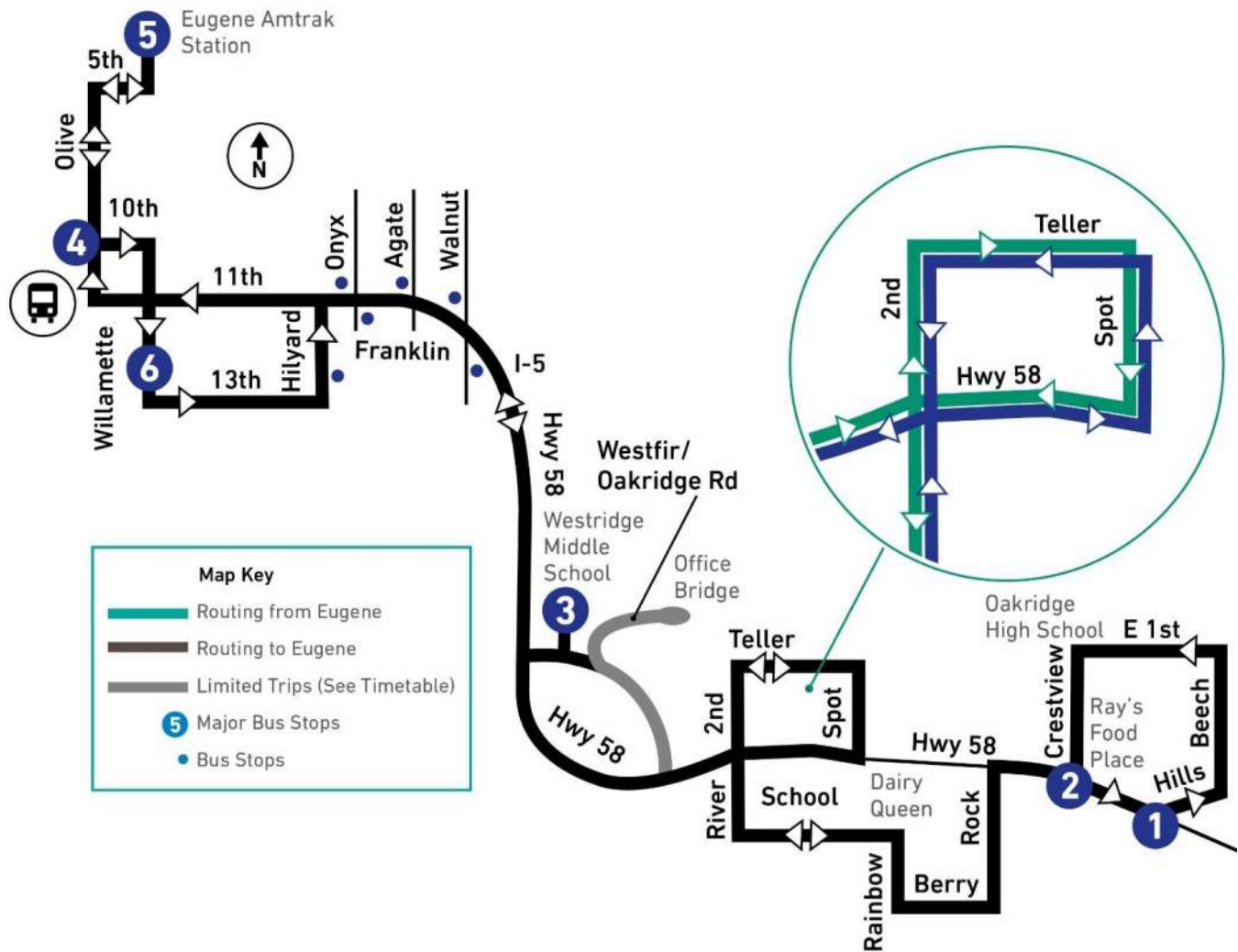

Figure 31. LTD transit map (source: [https://www.ltd.org/system-map/route\\_900/](https://www.ltd.org/system-map/route_900/))

**Table 15. Diamond Express Service Schedule**

Eugene Amtrak Station	Downtown Eugene	Westridge Middle School (Westfir)	Crestview & IR 58/Ray's Food Place
7:40 AM	7:45 AM	8:35 AM*	8:55 AM
10:40 AM	10:45 AM	11:35 AM*	11:55 AM
5:30 PM	5:40 PM	6:30 PM**	7:00 PM

\*Serves Westridge Middle School only when requested by riders.

\*\*Limited Trip Serves Westridge Middle School before serving the Westfir Office Bridge.

The Seniors and Disabled Services Center provides volunteer drivers to transport individuals in need to Diamond Express bus stop locations. These drivers are volunteers only and may not provide timely service to individuals.

## RAIL SYSTEM

The Union Pacific Railroad Company owns and operates the rail lines in Oakridge. The rail system through Oakridge connects Eugene and Klamath Falls and serves as part of a mainline between Seattle and Los Angeles. Union Pacific owns the rail yard and tracks through Oakridge.

Figure 32 shows the existing railroad facilities in Oakridge. There are two grade-separated rail crossings: one at Crestview Street and one at W 2<sup>nd</sup> Street. All other crossings are at-grade. All of the at-grade crossings have grade crossing signals with flashing lights with the exception of the private crossing at Rodgers Road. The Rogers Road crossing is stop controlled.

### FREIGHT

According to 2015 records, an average of 19 freight trains pass through Oakridge daily. There are currently no freight stops in Oakridge. The rail yard is located in the center of the City between Commercial Street and Railroad Avenue. The rail yard currently serves as a rail-car disengagement and reconfiguration staging area. A small service building is located on Railroad Avenue as a maintenance and operations station for reconfiguration assistance. A spur is located between the rail yard and Industrial Park that is reserved for private business usage upon approval of Union Pacific. This spur is currently unused.

### PASSENGER

Amtrak contracts with Union Pacific to use the track for their service through Oakridge. Although Amtrak trains travel through the City, there are no stops and therefore no passenger rail service provided in Oakridge. According to 2015 records, an average of three passenger trains travel through the City daily. Amtrak provides services throughout the northwest and Oregon. The Coast Starlight line provides passenger service from Seattle to Los Angeles by means of Salem, Eugene, and Klamath Falls. The Eugene station is the nearest Amtrak station to Oakridge. The next closest Amtrak station to the east is in Chemult.

As noted in the previous TSP, Oakridge continues to express interest in a passenger rail stop in the community. Since the line is owned and operated by Union Pacific, any passenger stop accommodations must be verified and agreed upon by Union Pacific.

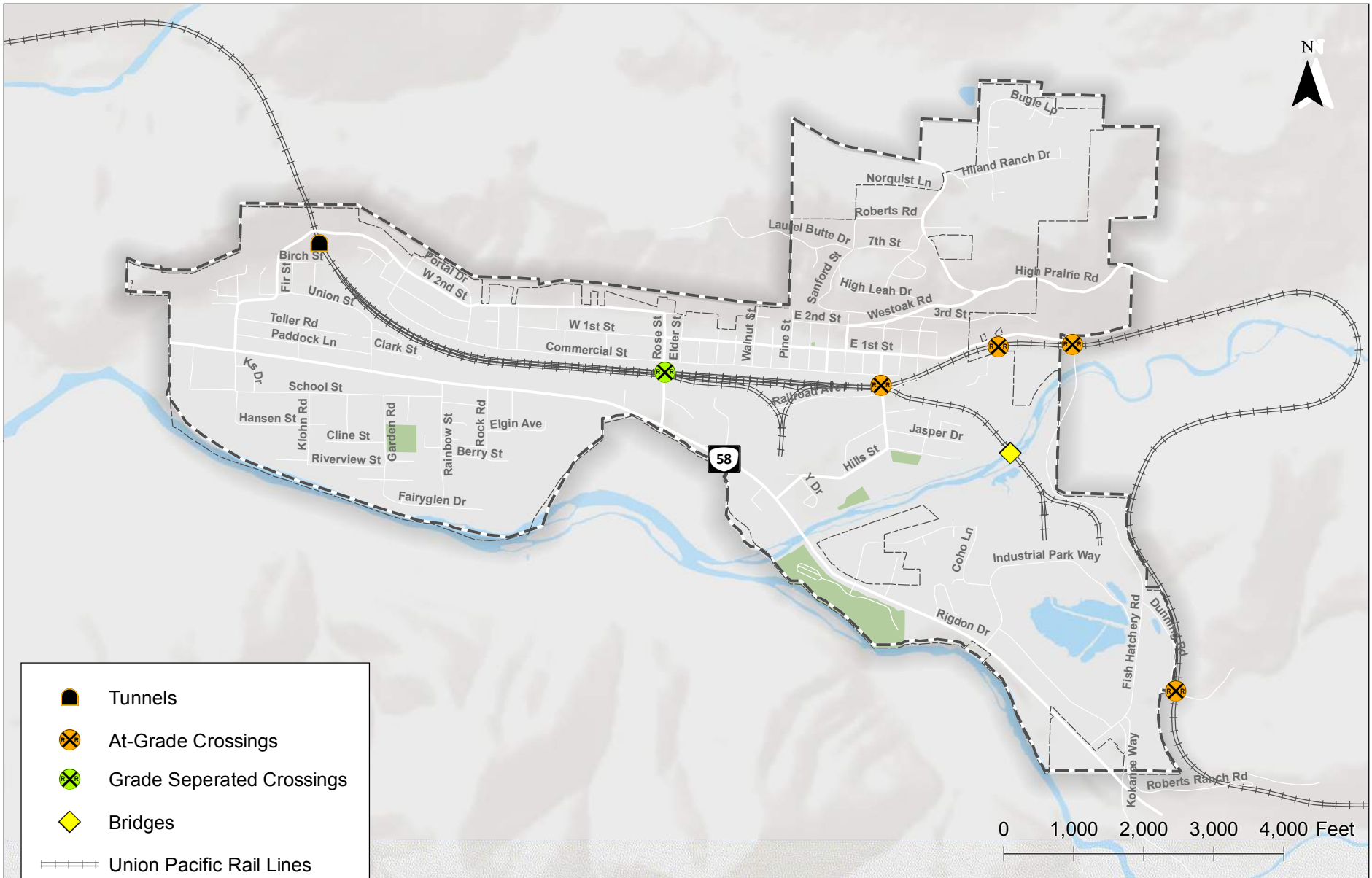

**Railroad Facilities  
Oakridge, Oregon**

**Figure  
32**

H:\22\22477 - Oakridge TSP Update\GIS\Memo 4 - System Conditions and Deficiencies\Figure 32 - Railroad Facilities.mxd - aludwig - 2:54 PM 12/14/2018

---

## AIR TRANSPORTATION SYSTEM

---

The Oakridge State Airport (5S0) is a state-owned airport located just west of the City UGB. The Airport is classified as a Class IV, Community General Aviation Airport, by the Oregon Department of Aviation. It accommodates general aviation users and local business activities, primarily used by corporate light jet and turbine traffic for general aviation/business purposes. Public passenger or freight services are not provided. It also facilitates fire support helicopters and fixed wing operations primarily during the fire seasons. The airport has 2,500 or more annual operations or more than ten aircraft based on site.

The airport has one runway that is 3,610 feet long by 50 feet wide. The runway is oriented east-west with the only access coming from Airport Road (a County owned and maintained roadway), via OR 58. A helipad is located northeast of the runway. Private hangers, public tie-downs, and parking is located northeast of the runway. As the airport is not heavily traveled, there is no air traffic control at the airport. The airport is not part of the National Plan of Integrated Airport Systems (NPIAS).

---

## ALTERNATIVE TRANSPORTATION NEEDS

---

This section summarizes the alternative transportation needs identified for Oakridge:

► Pedestrian and Bicycle Needs

- Sidewalk gaps and deficiencies exist within the Oakridge UGB, including along key arterials and collectors such as Westoak Road, W 2<sup>nd</sup> Street, and W 1<sup>st</sup> Street. The pedestrian qualitative assessment summarizes the roads that provide fair or poor condition for pedestrians.
- There are limited pedestrian facilities on local roads.
- There are existing gaps on the sidewalk system near the school including local connections from Commercial Street to 1<sup>st</sup> Street. In addition, pedestrian connections between the residential areas (south of OR 58 and northeast of the City) and the schools do not exist. A complete multimodal system is necessary for students who need to bike or walk to school.
- There are substantial gaps to the sidewalk network on OR 58 particularly east of Rainbow Street where no sidewalk exists.
- OR 58 creates a barrier and large exposure area for pedestrians and bicycles crossing the highway. The exposure area ranges from 55 to 60 feet in distance. Only one enhanced crossing with a pedestrian refuge island is available within the City. There are no marked crosswalks near the Willamette Activity Center or other trip generators such as churches or businesses.
- There are a lack of multimodal railroad crossings throughout the community. The illegal dirt path crossing between Union Street and Commercial Street indicates a demand for additional safe railroad crossings for north-south connectivity.
- There are limited dedicated bicycle facilities in Oakridge. The majority of arterials and collectors do not provide bicycle facilities. The bicycle qualitative assessment summarizes the roads that provide fair or poor conditions for bicyclists.
- Although OR 58 is one of the only east-west available and Strava data shows that cyclists ride on the road, there are no dedicated facilities for bicyclists. This create potential conflicts between vehicles and bicyclists due to the higher speeds on OR 58.
- There are limited bicycle connections between the City and popular nearby trails. Additionally, there is limited wayfinding in town to trails and key connections.



- The 2016 Pedestrian Safety Study identified crossing improvements and corridor safety treatments including street lighting, speed feedback signs, and a lane conversion of OR 58.
- ▶ Transit Needs
  - There is not a public dial-a-ride transit service in the City to provide accommodations for citizens who need additional assistance or are unable to use the Diamond Express buses.
  - The existing Diamond Express route provides limited services to Oakridge (3 stops per day, only on weekdays).
- ▶ Rail Needs
  - There are no freight rail stops in Oakridge.
  - There are no passenger rail stops in Oakridge.

## 06 | BRIDGE , MARINE AND PIPELINE SYSTEM

This section identifies the existing bridges, pipelines, and marine waterways within the City. No needs were identified for these systems.

### BRIDGE

There are two bridges located within the City UGB and two bridges located just outside of the UGB. These bridges are summarized in Table 16. Two bridges are located on OR 58. These are owned and maintained by the state. A grade separated rail crossing is located on Crestview Street. This bridge is owned and maintained by the City. Another bridge is located just outside the UGB on Fish Hatchery Road across Salmon Creek. This bridge is owned and maintained by the County. *A detailed listing of the bridges is included in Appendix I.*

A bridge sufficiency rating is calculated by the Federal Highway Administration (FHWA) based on factors such as condition, materials, load capacity, and geometry (i.e., dimensions). FHWA uses the rating as a tool to prioritize the allocation of funds for bridge repairs. In general, bridges with a sufficiency rating of less than 50 (on a scale of 0 to 100) are given priority. In reviewing the ratings, it is important to note that a low rating may be an indication of an older bridge that is narrow and not designed to the same width or height clearance of today's standards; a low sufficiency rating does not necessarily indicate a structural issue. Table 16 provides the sufficiency rating for the bridges within and just outside of the Oakridge UGB.

According to the 2018 ODOT Bridge Condition Report, there are no bridges in the Oakridge UGB with sufficiency ratings below 50 or classified as "structurally deficient."

**Table 16. Bridges within or near Oakridge UGB**

Roadway	Location of Bridge	Jurisdiction	Within UGB?	Sufficiency Rating
OR 58	Salmon Creek	ODOT	Yes	78.6
OR 58	Private Logging Road	ODOT	No	79.4
Crestview Street	Railroad	City	Yes	81.1
Fish Hatchery Road	Salmon Creek	County	No	92.8*

\*The sufficiency rating for the Fish Hatchery Road bridge was obtained from ODOT's TransGIS website on December 13, 2018.

---

## PIPELINE

---

Pipelines are vessels for transporting mass liquids or gases long distances. There are no pipeline facilities in Oakridge.

---

## MARINE

---

There are no navigable waterways within the City or surrounding area. The Willamette River is located on the southern boundary of Oakridge. There are five streams in the Oakridge area including: Salmon Creek, Salt Creek, Hills Creek, and the Middle and North Forks of the Willamette River. The Middle Fork adjacent to Greenwaters Park is used for recreational use only.

# 07 | SUMMARY OF NEEDS

This section summarizes the needs identified throughout this memorandum. These alternatives analysis will identify recommendations of projects, programs, policies, and studies to address these needs.

- ▶ Street System Inventory Needs
  - The current functional classification system lacks east-west connected and continuous arterials.
  - The freight system does not designate any City or County roads as freight routes. There are no designated freight routes serving the industrial area.
  - The Oregon Freight Plan identifies a need for passing lanes on OR 58. The multilane cross section within city limits creates a defacto passing lane.
  - The transition back to a two-lane section on the east end of town results in potential conflicts for eastbound vehicles attempting to complete passing movements in the left-lane and those waiting to turn left into the Industrial Park.
  - There are limited options for truck stops on OR 58 between Eugene and Chemult.
  - The City's current roadway standards identify sidewalks with minimum widths less than 6 feet.
- ▶ Intersection and Street Operations Needs
  - Vehicle travel speeds on OR 58 within the city limits exceed the posted speed limit by 4 to 6 mph.
- ▶ Safety Needs
  - The three reported pedestrian and bicycle crashes within the City occurred on OR 58. OR 58 has limited facilities available for travel along and across the highway. This will be further discussed in the Alternative Transportation Analysis section of the memo.
  - Several intersection and segment safety concerns were identified by the community. These locations will be further analyzed to determine risk factors and potential improvements.
- ▶ Pedestrian and Bicycle Needs
  - Sidewalk gaps and deficiencies exist within the Oakridge UGB, including along key arterials and collectors such as Westoak Road, W 2<sup>nd</sup> Street, and W 1<sup>st</sup> Street. The pedestrian qualitative assessment summarizes the roads that provide fair or poor condition for pedestrians.
  - There are limited pedestrian facilities on local roads.
  - There are existing gaps on the sidewalk system near the school including local connections from Commercial Street to 1<sup>st</sup> Street. In addition, pedestrian connections between the residential areas (south of

OR 58 and northeast of the City) and the schools do not exist. A complete multimodal system is necessary for students who need to bike or walk to school.

- There are substantial gaps to the sidewalk network on OR 58 particularly east of Rainbow Street where no sidewalk exists.
- OR 58 creates a barrier and large exposure area for pedestrians and bicycles crossing the highway. The exposure area ranges from 55 to 60 feet in distance. Only one enhanced crossing with a pedestrian refuge island is available within the City. There are no marked crosswalks near the Willamette Activity Center or other trip generators such as churches or businesses.
- There are a lack of multimodal railroad crossings throughout the community. The illegal dirt path crossing between Union Street and Commercial Street indicates a demand for additional safe railroad crossings for north-south connectivity.
- There are limited dedicated bicycle facilities in Oakridge. The majority of arterials and collectors do not provide bicycle facilities. The bicycle qualitative assessment summarizes the roads that provide fair or poor conditions for bicyclists.
- Although OR 58 is one of the only east-west available and Strava data shows that cyclists ride on the road, there are no dedicated facilities for bicyclists. This create potential conflicts between vehicles and bicyclists due to the higher speeds on OR 58.
- There are limited bicycle connections between the City and popular nearby trails. Additionally, there is limited wayfinding in town to trails and key connections.
- The 2016 Pedestrian Safety Study identified crossing improvements and corridor safety treatments including street lighting, speed feedback signs, and a lane conversion of OR 58.

► Transit Needs

- There is not a public dial-a-ride transit service in the City to provide accommodations for citizens who need additional assistance or are unable to use the Diamond Express buses.
- The existing Diamond Express route provides limited services to Oakridge (3 stops per day, only on weekdays).

► Rail Needs

- There are no freight rail stops in Oakridge.
- There are no passenger rail stops in Oakridge.

## APPENDICES

Appendix A: Traffic Counts

Appendix B: 2000 Oakridge TSP Cross Sections

Appendix C: Methodology Memorandum

Appendix D: Existing Conditions Operations Worksheets

Appendix E: Future Conditions Operations Worksheets

Appendix F: Critical Crash Rate Calculations

Appendix G: Pedestrian Qualitative Analysis Table

Appendix H: Bicycle Qualitative Analysis Table

Appendix I: Bridge Inventory

## Appendix A – Traffic Counts

**LOCATION:** 45774 -- Conversion  
**CITY/STATE:** Oakridge, OR

**QC JOB #:** 14761202  
**DATE:** Tue, Jul 10 2018

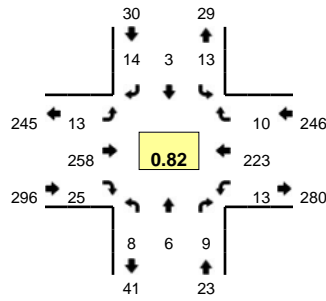

**Peak-Hour: 4:00 PM -- 5:00 PM**  
**Peak 15-Min: 4:00 PM -- 4:15 PM**

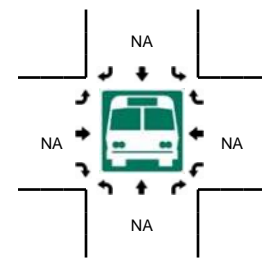
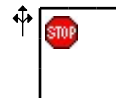
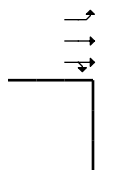
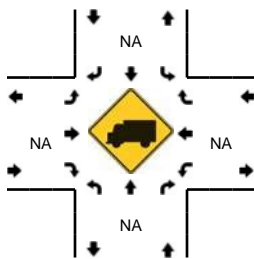
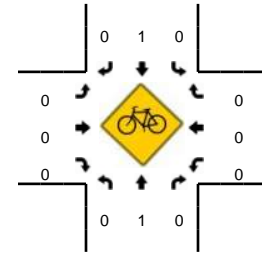
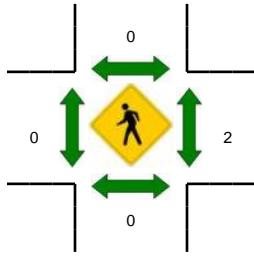
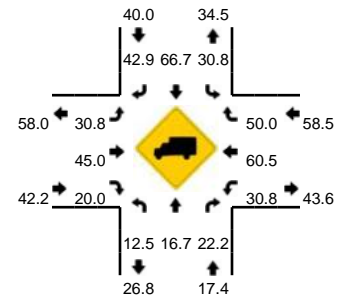

15-Min Count Period Beginning At	45774 (Northbound)				45774 (Southbound)				Conversion (Eastbound)				Conversion (Westbound)				Total	Hourly Totals
	Left	Thru	Right	U	Left	Thru	Right	U	Left	Thru	Right	U	Left	Thru	Right	U		
4:00 PM	1	2	1	0	1	1	3	0	0	90	6	0	6	68	3	0	182	
4:15 PM	3	2	0	0	6	0	6	0	5	59	5	0	4	61	3	0	154	
4:30 PM	1	2	2	0	2	1	2	0	4	55	9	0	1	54	1	0	134	
4:45 PM	3	0	6	0	4	1	3	0	4	54	5	0	2	40	3	0	125	595
5:00 PM	1	0	6	0	2	0	2	0	4	61	4	0	3	68	2	0	153	566
5:15 PM	4	0	6	0	0	1	2	0	8	65	0	0	0	47	2	0	135	547
5:30 PM	1	4	4	0	1	0	0	0	7	78	1	0	3	52	3	0	154	567
5:45 PM	2	1	2	0	2	1	2	0	10	50	8	0	3	39	3	0	123	565
Peak 15-Min Flowrates	Northbound				Southbound				Eastbound				Westbound				Total	
All Vehicles	4	8	4	0	4	4	12	0	0	360	24	0	24	272	12	0	728	
Heavy Trucks	0	0	4		4	4	8		0	144	4		12	248	4		432	
Pedestrians	0	0	0		0	0	0		0	0	0		0	0	0		0	
Bicycles	0	0	0		0	0	0		0	0	0		0	0	0		0	
Railroad																		
Stopped Buses																		

Comments:

**LOCATION:** 45775 -- Conversion  
**CITY/STATE:** Oakridge, OR

**QC JOB #:** 14761203  
**DATE:** Tue, Jul 10 2018

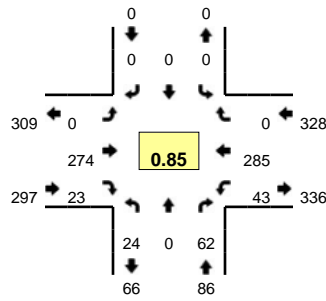

**Peak-Hour: 4:00 PM -- 5:00 PM**  
**Peak 15-Min: 4:00 PM -- 4:15 PM**

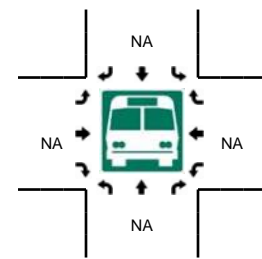
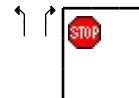
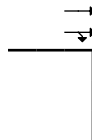
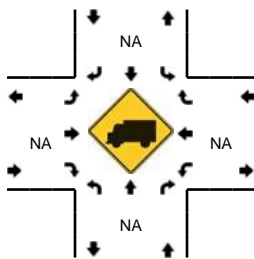
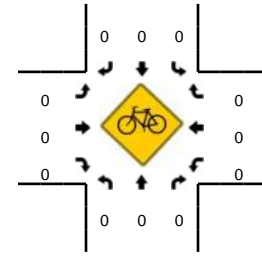
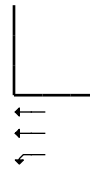
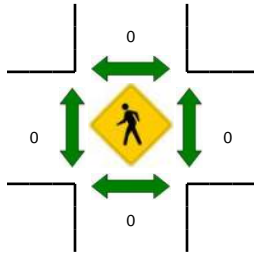
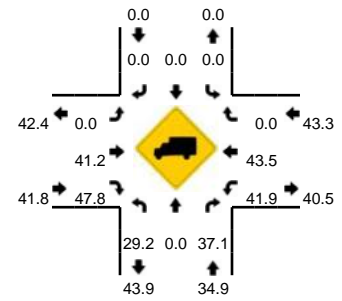

15-Min Count Period Beginning At	45775 (Northbound)				45775 (Southbound)				Conversion (Eastbound)				Conversion (Westbound)				Total	Hourly Totals
	Left	Thru	Right	U	Left	Thru	Right	U	Left	Thru	Right	U	Left	Thru	Right	U		
4:00 PM	10	0	15	0	0	0	0	0	0	85	11	0	11	77	0	0	209	
4:15 PM	5	0	20	0	0	0	0	0	0	62	5	0	14	73	0	0	179	
4:30 PM	3	0	9	0	0	0	0	0	0	70	3	0	11	70	0	0	166	
4:45 PM	6	0	18	0	0	0	0	0	0	57	4	0	7	65	0	0	157	711
5:00 PM	4	0	11	0	0	0	0	0	0	70	11	0	11	68	0	0	175	677
5:15 PM	4	0	12	0	0	0	0	0	0	70	4	0	16	64	0	0	170	668
5:30 PM	4	0	4	0	0	0	0	0	0	82	7	0	18	50	0	0	165	667
5:45 PM	8	0	2	0	0	0	0	0	0	58	1	0	45	47	0	0	161	671
<b>Peak 15-Min Flowrates</b>	<b>Northbound</b>				<b>Southbound</b>				<b>Eastbound</b>				<b>Westbound</b>				<b>Total</b>	
All Vehicles	40	0	60	0	0	0	0	0	0	340	44	0	44	308	0	0	836	
Heavy Trucks	16	0	24		0	0	0		0	144	20		12	124	0		340	
Pedestrians			0				0			0				0			0	
Bicycles	0	0	0		0	0	0		0	0	0		0	0	0		0	
Railroad																		
Stopped Buses																		

Comments:

**LOCATION:** 45773 -- Conversion  
**CITY/STATE:** Oakridge, OR

**QC JOB #:** 14761201  
**DATE:** Tue, Jul 10 2018

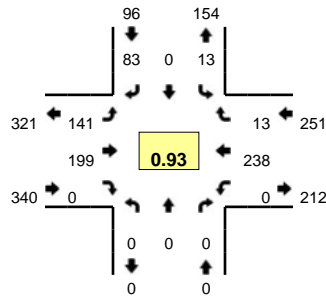

**Peak-Hour: 4:00 PM -- 5:00 PM**  
**Peak 15-Min: 4:15 PM -- 4:30 PM**

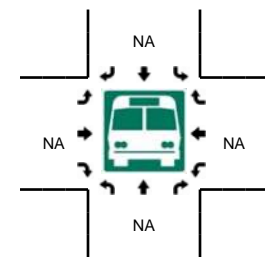
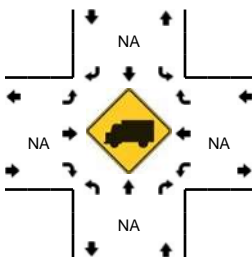
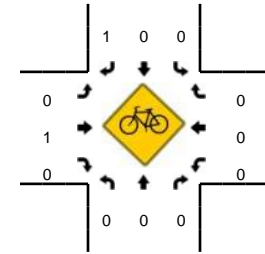
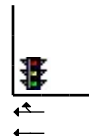
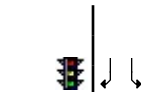
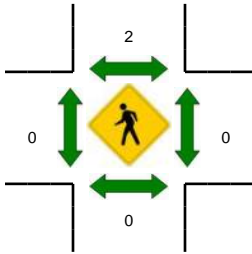
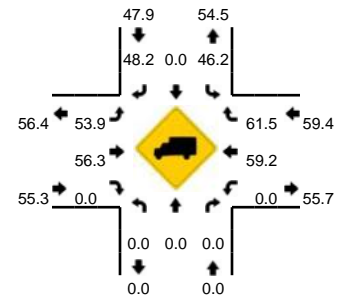

15-Min Count Period Beginning At	45773 (Northbound)				45773 (Southbound)				Conversion (Eastbound)				Conversion (Westbound)				Total	Hourly Totals
	Left	Thru	Right	U	Left	Thru	Right	U	Left	Thru	Right	U	Left	Thru	Right	U		
4:00 PM	0	0	0	0	2	0	22	0	32	48	0	0	0	73	5	0	182	
4:15 PM	0	0	0	0	6	0	27	0	44	50	0	0	0	54	4	0	185	
4:30 PM	0	0	0	0	1	0	14	0	34	51	0	0	0	58	4	0	162	
4:45 PM	0	0	0	0	4	0	20	0	31	50	0	0	0	53	0	0	158	687
5:00 PM	0	0	0	0	1	0	24	0	33	50	0	0	0	52	3	0	163	668
5:15 PM	0	0	0	0	2	0	27	0	29	44	0	0	0	56	2	0	160	643
5:30 PM	0	0	0	0	0	0	20	0	40	59	0	0	0	46	3	0	168	649
5:45 PM	0	0	0	0	1	0	17	0	28	49	0	0	0	43	6	0	144	635
<b>Peak 15-Min Flowrates</b>	<b>Northbound</b>				<b>Southbound</b>				<b>Eastbound</b>				<b>Westbound</b>				<b>Total</b>	
All Vehicles	0	0	0	0	24	0	108	0	176	200	0	0	0	216	16	0	740	
Heavy Trucks	0	0	0	0	12	0	40	0	64	108	0	0	0	148	12	0	384	
Pedestrians						4				0				0			4	
Bicycles	0	0	0	0	0	0	1	0	0	0	0	0	0	0	0	0	1	
Railroad																		
Stopped Buses																		

Comments:

**LOCATION:** 45776 -- Conversion  
**CITY/STATE:** Oakridge, OR

**QC JOB #:** 14761204  
**DATE:** Tue, Jul 10 2018

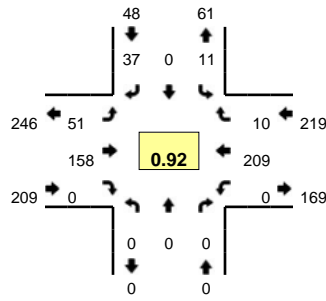

**Peak-Hour: 4:00 PM -- 5:00 PM**  
**Peak 15-Min: 4:00 PM -- 4:15 PM**

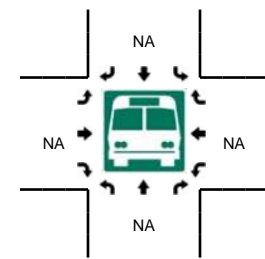
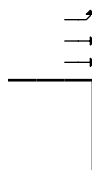
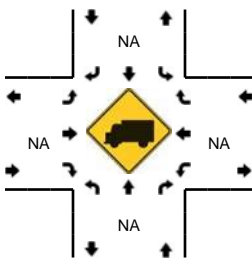
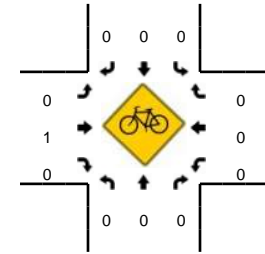
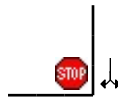
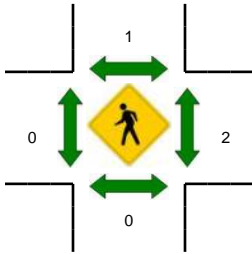
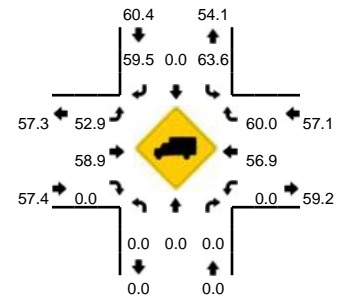

15-Min Count Period Beginning At	45776 (Northbound)				45776 (Southbound)				Conversion (Eastbound)				Conversion (Westbound)				Total	Hourly Totals
	Left	Thru	Right	U	Left	Thru	Right	U	Left	Thru	Right	U	Left	Thru	Right	U		
4:00 PM	0	0	0	0	2	0	9	0	17	34	0	0	0	67	1	0	130	
4:15 PM	0	0	0	0	1	0	11	0	10	49	0	0	0	50	3	0	124	
4:30 PM	0	0	0	0	4	0	12	0	13	42	0	0	0	44	2	0	117	
4:45 PM	0	0	0	0	4	0	5	0	11	33	0	0	0	48	4	0	105	476
5:00 PM	0	0	0	0	2	0	6	0	12	38	0	0	0	45	1	0	104	450
5:15 PM	0	0	0	0	3	0	12	0	12	33	0	0	0	43	3	0	106	432
5:30 PM	0	0	0	0	2	0	16	0	16	42	0	0	0	29	0	0	105	420
5:45 PM	0	0	0	0	0	0	8	0	16	35	0	0	0	37	6	0	102	417
Peak 15-Min Flowrates	Northbound				Southbound				Eastbound				Westbound				Total	
	Left	Thru	Right	U	Left	Thru	Right	U	Left	Thru	Right	U	Left	Thru	Right	U		
All Vehicles	0	0	0	0	8	0	36	0	68	136	0	0	0	268	4	0	520	
Heavy Trucks	0	0	0	0	4	0	16	0	40	72	0	0	0	172	4	0	308	
Pedestrians		0				0				0				4			4	
Bicycles	0	0	0		0	0	0		0	1	0		0	0	0		1	
Railroad																		
Stopped Buses																		

Comments:



**LOCATION:** 45777 -- Conversion  
**CITY/STATE:** Oakridge, OR

**QC JOB #:** 14761205  
**DATE:** Tue, Jul 10 2018

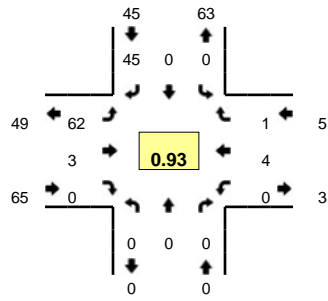

**Peak-Hour: 4:45 PM -- 5:45 PM**  
**Peak 15-Min: 4:45 PM -- 5:00 PM**

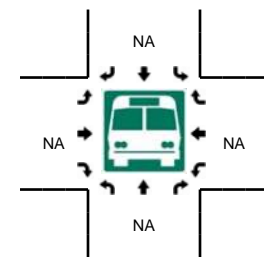
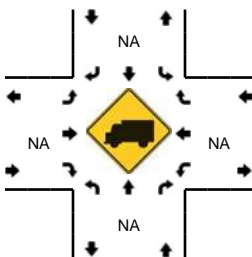
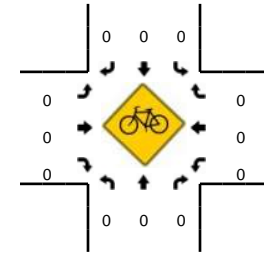
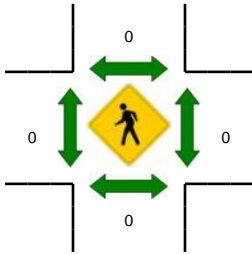
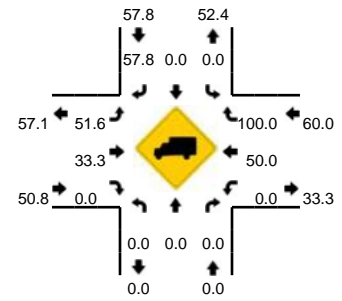

15-Min Count Period Beginning At	45777 (Northbound)				45777 (Southbound)				Conversion (Eastbound)				Conversion (Westbound)				Total	Hourly Totals
	Left	Thru	Right	U	Left	Thru	Right	U	Left	Thru	Right	U	Left	Thru	Right	U		
4:00 PM	0	0	0	0	0	0	12	0	14	1	0	0	0	0	0	0	27	
4:15 PM	0	0	0	0	1	0	9	0	24	1	0	0	0	0	0	0	35	
4:30 PM	0	0	0	0	0	0	6	0	13	0	0	0	0	0	0	0	19	
4:45 PM	0	0	0	0	0	0	11	0	17	2	0	0	0	1	0	0	31	112
5:00 PM	0	0	0	0	0	0	12	0	15	1	0	0	0	0	1	0	29	114
5:15 PM	0	0	0	0	0	0	15	0	10	0	0	0	0	1	0	0	26	105
5:30 PM	0	0	0	0	0	0	7	0	20	0	0	0	0	2	0	0	29	115
5:45 PM	0	0	0	0	0	0	13	0	14	0	0	0	0	1	0	0	28	112
Peak 15-Min Flowrates	Northbound				Southbound				Eastbound				Westbound				Total	
	Left	Thru	Right	U	Left	Thru	Right	U	Left	Thru	Right	U	Left	Thru	Right	U		
All Vehicles	0	0	0	0	0	0	44	0	68	8	0	0	0	4	0	0	124	
Heavy Trucks	0	0	0	0	0	0	28	0	28	4	0	0	0	0	0	0	60	
Pedestrians	0	0	0	0	0	0	0	0	0	0	0	0	0	0	0	0	0	
Bicycles	0	0	0	0	0	0	0	0	0	0	0	0	0	0	0	0	0	
Railroad	0	0	0	0	0	0	0	0	0	0	0	0	0	0	0	0	0	
Stopped Buses	0	0	0	0	0	0	0	0	0	0	0	0	0	0	0	0	0	

Comments:

**LOCATION:** 45778 -- Conversion  
**CITY/STATE:** Oakridge, OR

**QC JOB #:** 14761206  
**DATE:** Tue, Jul 10 2018

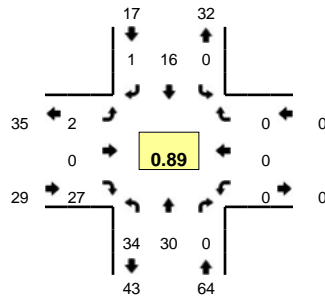

**Peak-Hour: 4:00 PM -- 5:00 PM**  
**Peak 15-Min: 4:15 PM -- 4:30 PM**

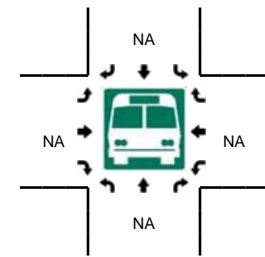
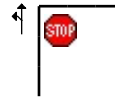
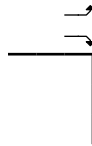
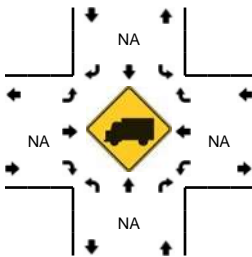
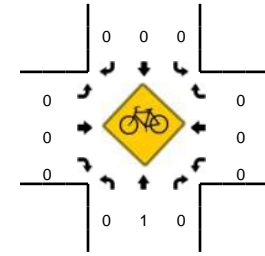
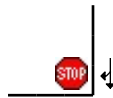
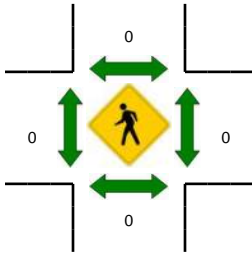
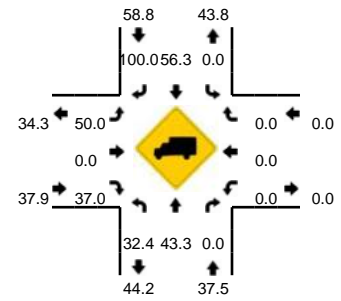

15-Min Count Period Beginning At	45778 (Northbound)				45778 (Southbound)				Conversion (Eastbound)				Conversion (Westbound)				Total	Hourly Totals
	Left	Thru	Right	U	Left	Thru	Right	U	Left	Thru	Right	U	Left	Thru	Right	U		
4:00 PM	10	6	0	0	0	1	0	0	0	0	10	0	0	0	0	0	27	
4:15 PM	4	9	0	0	0	8	1	0	0	0	9	0	0	0	0	0	31	
4:30 PM	6	8	0	0	0	5	0	0	0	0	4	0	0	0	0	0	23	
4:45 PM	14	7	0	0	0	2	0	0	2	0	4	0	0	0	0	0	29	110
5:00 PM	2	5	0	0	0	3	0	0	0	0	4	0	0	0	0	0	14	97
5:15 PM	5	4	0	0	0	2	1	0	0	0	6	0	0	0	0	0	18	84
5:30 PM	13	15	0	0	0	1	0	0	0	0	6	0	0	0	0	0	35	96
5:45 PM	6	3	0	0	0	2	1	0	0	0	8	0	0	0	0	0	20	87
Peak 15-Min Flowrates	Northbound				Southbound				Eastbound				Westbound				Total	
All Vehicles	16	36	0	0	0	32	4	0	0	0	36	0	0	0	0	0	124	
Heavy Trucks	8	8	0	0	0	12	4	0	0	0	12	0	0	0	0	0	44	
Pedestrians	0	0	0	0	0	0	0	0	0	0	0	0	0	0	0	0	0	
Bicycles	0	1	0	0	0	0	0	0	0	0	0	0	0	0	0	0	1	
Railroad																		
Stopped Buses																		

Comments:

## Transportation Development Division Transportation System Monitoring Unit Vehicular Volume

### Time settings

Date: 10/30/2018  
Hours: 2:00 PM-4:00 PM  
Weather: Cloudy

### Source

Site Number: 48571  
Mile Point: 0.24  
Street Number: 1628  
Vehicle Type: Vehicles  
Crossing Flow: Pedestrians

### Source Description

Location Description: Crestview Street at 1st Street/Rose Street  
County: Lane  
City: Oakridge

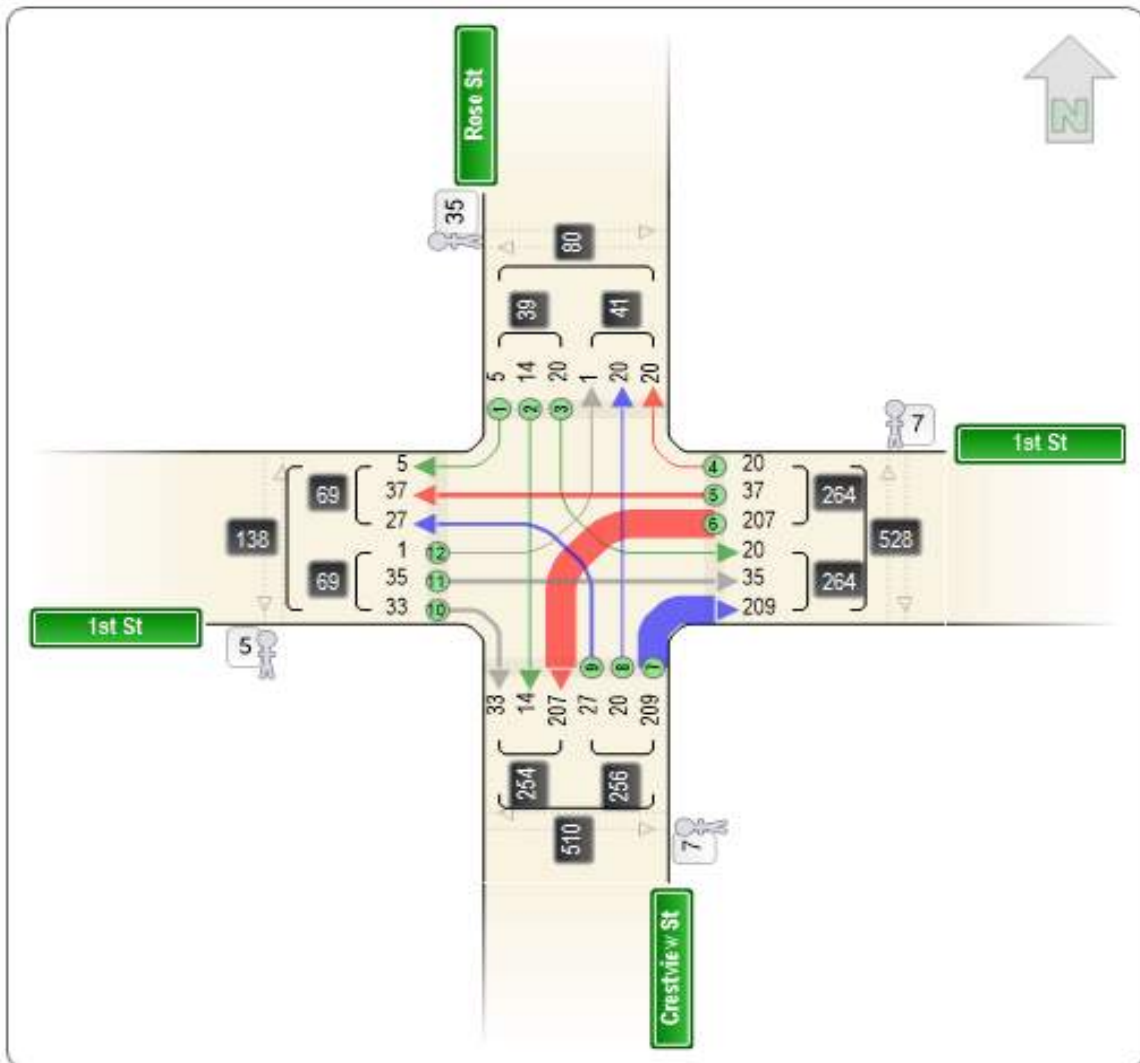

<b>LOCATION:</b> 45771 Conversion <b>SPECIFIC LOCATION:</b> 45771 Conversion <b>CITY/STATE:</b> Oakridge, OR						<b>QC JOB #:</b> 14761213 <b>DIRECTION:</b> EB/WB <b>DATE:</b> Jul 10 2018 - Jul 12 2018				
Start Time	Mon 10-Jul-18	Tue 11-Jul-18	Wed 12-Jul-18	Thu 12-Jul-18	Fri	Average Weekday Hourly Traffic	Sat	Sun	Average Week Hourly Traffic	Average Week Profile
12:00 AM		0	49	51		33			33	
1:00 AM		0	37	46		28			28	
2:00 AM		0	23	34		19			19	
3:00 AM		0	44	42		29			29	
4:00 AM		37	67	60		55			55	
5:00 AM		116	122	114		117			117	
6:00 AM		205	207	83		165			165	
7:00 AM		300	324	0		208			208	
8:00 AM		422	431	0		284			284	
9:00 AM		553	596	0		383			383	
10:00 AM		678	615	0		431			431	
11:00 AM		672	707	0		460			460	
12:00 PM		710	759	0		490			490	
1:00 PM		683	732	0		472			472	
2:00 PM		662	753	0		472			472	
3:00 PM		693	708	0		467			467	
4:00 PM		665	677	0		447			447	
5:00 PM		613	611	0		408			408	
6:00 PM		496	469	0		322			322	
7:00 PM		414	397	0		270			270	
8:00 PM		279	309	0		196			196	
9:00 PM		207	233	0		147			147	
10:00 PM		100	131	0		77			77	
11:00 PM		63	79	0		47			47	
<b>Day Total</b>		8568	9080	430		6027			6027	
% Weekday Average		142.2%	150.7%	7.1%						
% Week Average		142.2%	150.7%	7.1%		100.0%				
AM Peak		10:00 AM	11:00 AM	5:00 AM		11:00 AM			11:00 AM	
Volume		678	707	114		460			460	
PM Peak		12:00 PM	12:00 PM	12:00 PM		12:00 PM			12:00 PM	
Volume		710	759	0		490			490	
<i>Comments:</i>										

<b>LOCATION:</b> 45770 Conversion <b>SPECIFIC LOCATION:</b> 45770 Conversion <b>CITY/STATE:</b> Oakridge, OR						<b>QC JOB #:</b> 14761214 <b>DIRECTION:</b> EB/WB <b>DATE:</b> Jul 10 2018 - Jul 12 2018				
Start Time	Mon 10-Jul-18	Tue 11-Jul-18	Wed 12-Jul-18	Thu 12-Jul-18	Fri	Average Weekday Hourly Traffic	Sat	Sun	Average Week Hourly Traffic	Average Week Profile
12:00 AM		0	43	38		27			27	
1:00 AM		0	33	41		25			25	
2:00 AM		0	21	27		16			16	
3:00 AM		0	41	34		25			25	
4:00 AM		49	48	45		47			47	
5:00 AM		88	86	87		87			87	
6:00 AM		138	156	63		119			119	
7:00 AM		222	242	0		155			155	
8:00 AM		289	292	0		194			194	
9:00 AM		389	411	0		267			267	
10:00 AM		477	410	0		296			296	
11:00 AM		469	474	0		314			314	
12:00 PM		486	531	0		339			339	
1:00 PM		447	497	0		315			315	
2:00 PM		451	524	0		325			325	
3:00 PM		474	483	0		319			319	
4:00 PM		454	469	0		308			308	
5:00 PM		396	406	0		267			267	
6:00 PM		329	283	0		204			204	
7:00 PM		269	271	0		180			180	
8:00 PM		182	197	0		126			126	
9:00 PM		127	146	0		91			91	
10:00 PM		77	97	0		58			58	
11:00 PM		42	58	0		33			33	
<b>Day Total</b>		5855	6219	335		4137			4137	
% Weekday Average		141.5%	150.3%	8.1%						
% Week Average		141.5%	150.3%	8.1%		100.0%				
AM Peak		10:00 AM	11:00 AM	5:00 AM		11:00 AM			11:00 AM	
Volume		477	474	87		314			314	
PM Peak		12:00 PM	12:00 PM	12:00 PM		12:00 PM			12:00 PM	
Volume		486	531	0		339			339	
<i>Comments:</i>										

<b>LOCATION:</b> 45772 Conversion <b>SPECIFIC LOCATION:</b> 45772 Conversion <b>CITY/STATE:</b> Oakridge, OR						<b>QC JOB #:</b> 14761211 <b>DIRECTION:</b> NB/SB <b>DATE:</b> Jul 10 2018 - Jul 12 2018				
Start Time	Mon 10-Jul-18	Tue 11-Jul-18	Wed 12-Jul-18	Thu 12-Jul-18	Fri	Average Weekday Hourly Traffic	Sat	Sun	Average Week Hourly Traffic	Average Week Profile
12:00 AM		0	3	1		1			1	
1:00 AM		0	0	0		0			0	
2:00 AM		0	2	1		1			1	
3:00 AM		0	1	0		0			0	
4:00 AM		0	1	0		0			0	
5:00 AM		4	4	5		4			4	
6:00 AM		4	8	7		6			6	
7:00 AM		11	12	0		8			8	
8:00 AM		11	20	0		10			10	
9:00 AM		28	29	0		19			19	
10:00 AM		20	29	0		16			16	
11:00 AM		26	32	0		19			19	
12:00 PM		23	28	0		17			17	
1:00 PM		29	28	0		19			19	
2:00 PM		26	26	0		17			17	
3:00 PM		28	36	0		21			21	
4:00 PM		26	23	0		16			16	
5:00 PM		16	25	0		14			14	
6:00 PM		25	20	0		15			15	
7:00 PM		15	16	0		10			10	
8:00 PM		16	18	0		11			11	
9:00 PM		5	6	0		4			4	
10:00 PM		4	1	0		2			2	
11:00 PM		3	0	0		1			1	
<b>Day Total</b>		320	368	14		231			231	
% Weekday Average		138.5%	159.3%	6.1%						
% Week Average		138.5%	159.3%	6.1%		100.0%				
AM Peak		9:00 AM	11:00 AM	6:00 AM		9:00 AM			9:00 AM	
Volume		28	32	7		19			19	
PM Peak		1:00 PM	3:00 PM	12:00 PM		3:00 PM			3:00 PM	
Volume		29	36	0		21			21	
<i>Comments:</i>										

<b>LOCATION:</b> 20915 (24HR) Conversion (On Beech St, 0.02 mile south of Railroad Ave) <b>SPECIFIC LOCATION:</b> 20915 (24HR) Conversion (On Beech St, 0.02 mile south of Railroad Ave) <b>CITY/STATE:</b> Oakridge, OR						<b>QC JOB #:</b> 14761215 <b>DIRECTION:</b> NB/SB <b>DATE:</b> Jul 10 2018 - Jul 10 2018				
Start Time	Mon	Tue 10-Jul-18	Wed	Thu	Fri	Average Weekday Hourly Traffic	Sat	Sun	Average Week Hourly Traffic	Average Week Profile
12:00 AM		4				4			4	
1:00 AM		4				4			4	
2:00 AM		6				6			6	
3:00 AM		3				3			3	
4:00 AM		11				11			11	
5:00 AM		21				21			21	
6:00 AM		29				29			29	
7:00 AM		59				59			59	
8:00 AM		75				75			75	
9:00 AM		85				85			85	
10:00 AM		88				88			88	
11:00 AM		103				103			103	
12:00 PM		94				94			94	
1:00 PM		101				101			101	
2:00 PM		95				95			95	
3:00 PM		85				85			85	
4:00 PM		87				87			87	
5:00 PM		74				74			74	
6:00 PM		53				53			53	
7:00 PM		43				43			43	
8:00 PM		38				38			38	
9:00 PM		29				29			29	
10:00 PM		16				16			16	
11:00 PM		8				8			8	
<b>Day Total</b>		1211				1211			1211	
% Weekday Average		100.0%								
% Week Average		100.0%				100.0%				
AM Peak		11:00 AM				11:00 AM			11:00 AM	
Volume		103				103			103	
PM Peak		1:00 PM				1:00 PM			1:00 PM	
Volume		101				101			101	
<i>Comments:</i>										

<b>LOCATION:</b> 45771 Conversion <b>SPECIFIC LOCATION:</b> 45771 Conversion <b>CITY/STATE:</b> Oakridge, OR															<b>QC JOB #:</b> 14761213 <b>DIRECTION:</b> EB/WB <b>DATE:</b> Jul 10 2018			
Start Time	1 15	16 20	21 25	26 30	31 35	36 40	41 45	46 50	51 55	56 60	61 65	66 70	71 75	76 999	Total	Pace Speed	Number in Pace	
12:00 AM	0	0	0	0	0	0	0	0	0	0	0	0	0	0	0	1-10	0	
1:00 AM	0	0	0	0	0	0	0	0	0	0	0	0	0	0	0	1-10	0	
2:00 AM	0	0	0	0	0	0	0	0	0	0	0	0	0	0	0	1-10	0	
3:00 AM	0	0	0	0	0	0	0	0	0	0	0	0	0	0	0	1-10	0	
4:00 AM	1	4	7	5	9	9	2	0	0	0	0	0	0	0	37	31-40	18	
5:00 AM	3	2	10	14	20	34	28	4	1	0	0	0	0	0	116	36-45	61	
6:00 AM	8	5	33	26	36	62	29	5	1	0	0	0	0	0	205	31-40	98	
7:00 AM	8	7	28	50	53	102	42	9	1	0	0	0	0	0	300	31-40	155	
8:00 AM	9	8	50	75	91	125	52	11	1	0	0	0	0	0	422	31-40	216	
9:00 AM	5	21	55	109	128	174	50	10	1	0	0	0	0	0	553	31-40	302	
10:00 AM	11	19	95	146	135	191	65	13	1	1	0	0	1	0	678	31-40	326	
11:00 AM	11	17	74	150	143	184	74	19	0	0	0	0	0	0	672	31-40	327	
12:00 PM	8	17	81	136	171	201	77	17	1	0	0	0	0	1	710	31-40	372	
1:00 PM	9	15	96	128	173	182	53	19	8	0	0	0	0	0	683	31-40	354	
2:00 PM	3	19	80	137	169	172	74	6	0	2	0	0	0	0	662	31-40	340	
3:00 PM	6	18	73	111	146	211	99	26	1	1	1	0	0	0	693	31-40	357	
4:00 PM	19	13	54	141	165	180	72	21	0	0	0	0	0	0	665	31-40	345	
5:00 PM	8	8	53	112	150	186	77	17	2	0	0	0	0	0	613	31-40	336	
6:00 PM	2	6	55	92	126	130	57	17	7	1	1	2	0	0	496	31-40	256	
7:00 PM	3	5	35	88	90	121	49	16	3	3	1	0	0	0	414	31-40	210	
8:00 PM	0	6	35	48	74	88	21	3	3	0	1	0	0	0	279	31-40	162	
9:00 PM	4	1	16	48	58	60	17	1	1	0	0	0	1	0	207	31-40	118	
10:00 PM	0	1	7	15	29	35	12	0	1	0	0	0	0	0	100	31-40	64	
11:00 PM	0	1	6	9	19	20	7	1	0	0	0	0	0	0	63	31-40	39	
<b>Day Total</b>	118	193	943	1640	1985	2467	957	215	33	8	4	2	2	1	8568	31-40	4451	
<b>Percent</b>	1.4%	2.3%	11.0%	19.1%	23.2%	28.8%	11.2%	2.5%	0.4%	0.1%	0.0%	0.0%	0.0%	0.0%				
<b>ADT</b> 8568																		
<b>AM Peak</b> Volume	10:00 AM	9:00 AM	10:00 AM	11:00 AM	11:00 AM	10:00 AM	11:00 AM	11:00 AM	5:00 AM	10:00 AM			10:00 AM		10:00 AM			
	11	21	95	150	143	191	74	19	1	1			1		678			
<b>PM Peak</b> Volume	4:00 PM	2:00 PM	1:00 PM	4:00 PM	1:00 PM	3:00 PM	3:00 PM	3:00 PM	1:00 PM	7:00 PM	3:00 PM	6:00 PM	9:00 PM	12:00 PM	12:00 PM			
	19	19	96	141	173	211	99	26	8	3	1	2	1	1	710			
<i>Comments:</i>																		



<b>LOCATION:</b> 45771 Conversion <b>SPECIFIC LOCATION:</b> 45771 Conversion <b>CITY/STATE:</b> Oakridge, OR															<b>QC JOB #:</b> 14761213 <b>DIRECTION:</b> EB/WB <b>DATE:</b> Jul 11 2018				
Start Time	1 15	16 20	21 25	26 30	31 35	36 40	41 45	46 50	51 55	56 60	61 65	66 70	71 75	76 999	Total	Pace Speed	Number in Pace		
12:00 AM	0	0	3	1	14	26	4	1	0	0	0	0	0	0	49	31-40	40		
1:00 AM	0	0	3	2	4	20	6	2	0	0	0	0	0	0	37	36-45	26		
2:00 AM	0	0	1	2	6	11	2	1	0	0	0	0	0	0	23	31-40	17		
3:00 AM	0	0	3	2	6	20	9	4	0	0	0	0	0	0	44	36-45	28		
4:00 AM	1	1	5	9	19	19	10	2	0	0	0	0	1	0	67	31-40	37		
5:00 AM	1	5	17	13	19	41	17	6	2	1	0	0	0	0	122	31-40	60		
6:00 AM	4	5	20	25	34	76	34	7	2	0	0	0	0	0	207	36-45	110		
7:00 AM	8	6	26	42	66	105	62	8	1	0	0	0	0	0	324	31-40	171		
8:00 AM	15	7	45	86	88	137	47	6	0	0	0	0	0	0	431	31-40	224		
9:00 AM	12	15	74	116	118	160	78	22	1	0	0	0	0	0	596	31-40	278		
10:00 AM	13	19	74	134	154	142	64	9	3	2	0	0	0	1	615	31-40	295		
11:00 AM	13	19	75	150	161	203	68	13	4	1	0	0	0	0	707	31-40	364		
12:00 PM	13	13	109	149	162	215	89	7	2	0	0	0	0	0	759	31-40	377		
1:00 PM	11	20	100	151	171	176	91	10	1	0	0	0	0	1	732	31-40	347		
2:00 PM	10	14	75	140	178	213	100	18	2	1	0	0	2	0	753	31-40	391		
3:00 PM	6	13	72	142	155	193	89	30	6	2	0	0	0	0	708	31-40	348		
4:00 PM	9	13	62	135	148	189	97	20	1	1	1	0	0	1	677	31-40	336		
5:00 PM	0	8	52	135	119	189	87	17	3	1	0	0	0	0	611	31-40	308		
6:00 PM	3	4	51	87	99	147	52	20	5	1	0	0	0	0	469	31-40	245		
7:00 PM	3	7	24	72	89	139	45	14	3	0	0	0	1	0	397	31-40	228		
8:00 PM	2	4	23	74	61	104	27	11	1	2	0	0	0	0	309	31-40	165		
9:00 PM	1	1	30	52	61	69	13	5	1	0	0	0	0	0	233	31-40	130		
10:00 PM	1	1	9	20	37	41	16	5	0	0	0	1	0	0	131	31-40	78		
11:00 PM	0	0	6	14	18	27	9	3	2	0	0	0	0	0	79	31-40	45		
<b>Day Total</b>	126	175	959	1753	1987	2662	1116	241	40	12	1	1	4	3	9080	31-40	4648		
<b>Percent</b>	1.4%	1.9%	10.6%	19.3%	21.9%	29.3%	12.3%	2.7%	0.4%	0.1%	0.0%	0.0%	0.0%	0.0%					
<b>ADT 9080</b>																			
<b>AM Peak Volume</b>	8:00 AM	10:00 AM	11:00 AM	11:00 AM	11:00 AM	11:00 AM	9:00 AM	9:00 AM	11:00 AM	10:00 AM					4:00 AM	10:00 AM	11:00 AM		
<b>PM Peak Volume</b>	12:00 PM	1:00 PM	12:00 PM	1:00 PM	2:00 PM	12:00 PM	2:00 PM	3:00 PM	3:00 PM	3:00 PM	4:00 PM	10:00 PM	2:00 PM	1:00 PM	12:00 PM				
<b>Volume</b>	15	19	75	150	161	203	78	22	4	2	1	1	2	1	759				
<i>Comments:</i>																			

<b>LOCATION:</b> 45771 Conversion <b>SPECIFIC LOCATION:</b> 45771 Conversion <b>CITY/STATE:</b> Oakridge, OR															<b>QC JOB #:</b> 14761213 <b>DIRECTION:</b> EB/WB <b>DATE:</b> Jul 12 2018		
Start Time	1 15	16 20	21 25	26 30	31 35	36 40	41 45	46 50	51 55	56 60	61 65	66 70	71 75	76 999	Total	Pace Speed	Number in Pace
12:00 AM	0	0	7	7	10	18	5	2	1	1	0	0	0	0	51	31-40	28
1:00 AM	0	0	5	4	10	10	9	4	3	0	1	0	0	0	46	31-40	20
2:00 AM	0	0	2	7	5	11	6	2	0	1	0	0	0	0	34	36-45	17
3:00 AM	0	0	5	2	8	19	7	1	0	0	0	0	0	0	42	35-44	26
4:00 AM	1	0	4	11	10	22	8	3	1	0	0	0	0	0	60	33-42	31
5:00 AM	1	0	18	11	19	41	20	3	1	0	0	0	0	0	114	36-45	61
6:00 AM	5	3	7	11	15	27	12	3	0	0	0	0	0	0	83	31-40	42
7:00 AM	0	0	0	0	0	0	0	0	0	0	0	0	0	0	0	1-10	0
8:00 AM	0	0	0	0	0	0	0	0	0	0	0	0	0	0	0	1-10	0
9:00 AM	0	0	0	0	0	0	0	0	0	0	0	0	0	0	0	1-10	0
10:00 AM	0	0	0	0	0	0	0	0	0	0	0	0	0	0	0	1-10	0
11:00 AM	0	0	0	0	0	0	0	0	0	0	0	0	0	0	0	1-10	0
12:00 PM	0	0	0	0	0	0	0	0	0	0	0	0	0	0	0	1-10	0
1:00 PM	0	0	0	0	0	0	0	0	0	0	0	0	0	0	0	1-10	0
2:00 PM	0	0	0	0	0	0	0	0	0	0	0	0	0	0	0	1-10	0
3:00 PM	0	0	0	0	0	0	0	0	0	0	0	0	0	0	0	1-10	0
4:00 PM	0	0	0	0	0	0	0	0	0	0	0	0	0	0	0	1-10	0
5:00 PM	0	0	0	0	0	0	0	0	0	0	0	0	0	0	0	1-10	0
6:00 PM	0	0	0	0	0	0	0	0	0	0	0	0	0	0	0	1-10	0
7:00 PM	0	0	0	0	0	0	0	0	0	0	0	0	0	0	0	1-10	0
8:00 PM	0	0	0	0	0	0	0	0	0	0	0	0	0	0	0	1-10	0
9:00 PM	0	0	0	0	0	0	0	0	0	0	0	0	0	0	0	1-10	0
10:00 PM	0	0	0	0	0	0	0	0	0	0	0	0	0	0	0	1-10	0
11:00 PM	0	0	0	0	0	0	0	0	0	0	0	0	0	0	0	1-10	0
<b>Day Total</b>	7	3	48	53	77	148	67	18	6	2	1	0	0	0	430	31-40	225
<b>Percent</b>	1.6%	0.7%	11.2%	12.3%	17.9%	34.4%	15.6%	4.2%	1.4%	0.5%	0.2%	0.0%	0.0%	0.0%			
<b>ADT</b> 430																	
<b>AM Peak</b> Volume	6:00 AM	6:00 AM	5:00 AM	4:00 AM	5:00 AM	5:00 AM	5:00 AM	1:00 AM	1:00 AM	12:00 AM	1:00 AM	5:00 AM					
	5	3	18	11	19	41	20	4	3	1	1	114					
<b>PM Peak</b> Volume															12:00 PM		
															0		
<i>Comments:</i>																	

<b>LOCATION:</b> 45771 Conversion														<b>QC JOB #:</b> 14761213			
<b>SPECIFIC LOCATION:</b> 45771 Conversion														<b>DIRECTION:</b> EB/WB			
<b>CITY/STATE:</b> Oakridge, OR														<b>DATE:</b> Jul 10 2018 - Jul 12 2018			
Start Time	1 15	16 20	21 25	26 30	31 35	36 40	41 45	46 50	51 55	56 60	61 65	66 70	71 75	76 999	Total	Pace Speed	Number in Pace
<b>Grand Total</b>	251	371	1950	3446	4049	5277	2140	474	79	22	6	3	6	4	18078	31-40	9326
<b>Percent</b>	1.4%	2.1%	10.8%	19.1%	22.4%	29.2%	11.8%	2.6%	0.4%	0.1%	0.0%	0.0%	0.0%	0.0%			
<b>Cumulative Percent</b>	1.4%	3.4%	14.2%	33.3%	55.7%	84.9%	96.7%	99.3%	99.8%	99.9%	99.9%	99.9%	100.0%	100.0%			
<b>ADT 6026</b>															<b>85th Percentile</b> 40 MPH <b>Mean Speed(Average)</b> 33 MPH		
<i>Comments:</i>															<b>Median</b> 33 MPH <b>Mode:</b> 38 MPH		



LOCATION: 45770 Conversion															QC JOB #: 14761214			
SPECIFIC LOCATION: 45770 Conversion															DIRECTION: EB/WB			
CITY/STATE: Oakridge, OR															DATE: Jul 10 2018			
Start Time	1 15	16 20	21 25	26 30	31 35	36 40	41 45	46 50	51 55	56 60	61 65	66 70	71 75	76 999	Total	Pace Speed	Number in Pace	
12:00 AM	0	0	0	0	0	0	0	0	0	0	0	0	0	0	0	1-10	0	
1:00 AM	0	0	0	0	0	0	0	0	0	0	0	0	0	0	0	1-10	0	
2:00 AM	0	0	0	0	0	0	0	0	0	0	0	0	0	0	0	1-10	0	
3:00 AM	0	0	0	0	0	0	0	0	0	0	0	0	0	0	0	1-10	0	
4:00 AM	2	1	2	7	13	17	6	1	0	0	0	0	0	0	49	31-40	29	
5:00 AM	1	0	2	4	19	35	23	4	0	0	0	0	0	0	88	36-45	57	
6:00 AM	1	2	6	5	28	60	25	10	1	0	0	0	0	0	138	31-40	88	
7:00 AM	1	6	13	15	50	88	42	7	0	0	0	0	0	0	222	31-40	138	
8:00 AM	1	6	9	18	79	103	59	13	1	0	0	0	0	0	289	31-40	182	
9:00 AM	4	12	23	40	104	136	53	16	1	0	0	0	0	0	389	31-40	239	
10:00 AM	4	15	18	65	143	145	70	8	7	2	0	0	0	0	477	31-40	288	
11:00 AM	5	17	21	54	117	158	75	19	2	1	0	0	0	0	469	31-40	275	
12:00 PM	0	15	13	51	137	175	76	17	1	1	0	0	0	0	486	31-40	312	
1:00 PM	3	14	19	45	131	146	69	15	5	0	0	0	0	0	447	31-40	277	
2:00 PM	5	13	22	60	110	168	60	8	4	1	0	0	0	0	451	31-40	278	
3:00 PM	4	15	17	54	102	172	85	22	3	0	0	0	0	0	474	31-40	273	
4:00 PM	5	12	29	55	118	148	67	18	1	1	0	0	0	0	454	31-40	266	
5:00 PM	4	8	13	33	103	153	67	13	2	0	0	0	0	0	396	31-40	256	
6:00 PM	5	9	16	45	73	115	48	12	4	1	0	1	0	0	329	31-40	188	
7:00 PM	0	7	9	23	77	97	37	12	5	2	0	0	0	0	269	31-40	173	
8:00 PM	0	7	2	21	61	67	16	5	1	2	0	0	0	0	182	31-40	128	
9:00 PM	0	2	2	14	47	44	14	3	1	0	0	0	0	0	127	31-40	91	
10:00 PM	0	2	4	9	19	33	8	1	1	0	0	0	0	0	77	31-40	51	
11:00 PM	0	0	0	1	12	23	5	1	0	0	0	0	0	0	42	31-40	35	
Day Total	45	163	240	619	1543	2083	905	205	40	11	0	1	0	0	5855	31-40	3626	
Percent	0.8%	2.8%	4.1%	10.6%	26.4%	35.6%	15.5%	3.5%	0.7%	0.2%	0.0%	0.0%	0.0%	0.0%				
ADT 5855																		
AM Peak Volume	11:00 AM	11:00 AM	9:00 AM	10:00 AM	10:00 AM	11:00 AM	11:00 AM	11:00 AM	10:00 AM	10:00 AM						10:00 AM		
	5	17	23	65	143	158	75	19	7	2						477		
PM Peak Volume	2:00 PM	12:00 PM	4:00 PM	2:00 PM	12:00 PM	12:00 PM	3:00 PM	3:00 PM	1:00 PM	7:00 PM	6:00 PM					12:00 PM		
	5	15	29	60	137	175	85	22	5	2	1					486		
Comments:																		

LOCATION: 45770 Conversion															QC JOB #: 14761214			
SPECIFIC LOCATION: 45770 Conversion															DIRECTION: EB/WB			
CITY/STATE: Oakridge, OR															DATE: Jul 11 2018			
Start Time	1 15	16 20	21 25	26 30	31 35	36 40	41 45	46 50	51 55	56 60	61 65	66 70	71 75	76 999	Total	Pace Speed	Number in Pace	
12:00 AM	0	0	0	1	14	21	5	0	1	1	0	0	0	0	43	31-40	35	
1:00 AM	0	0	0	1	6	21	3	2	0	0	0	0	0	0	33	31-40	27	
2:00 AM	0	0	1	0	6	8	5	1	0	0	0	0	0	0	21	31-40	14	
3:00 AM	0	0	1	1	8	17	9	5	0	0	0	0	0	0	41	36-45	25	
4:00 AM	0	2	1	3	8	19	10	4	0	0	0	1	0	0	48	36-45	29	
5:00 AM	0	0	2	2	22	35	17	4	3	1	0	0	0	0	86	31-40	57	
6:00 AM	1	2	3	6	34	71	29	6	4	0	0	0	0	0	156	31-40	104	
7:00 AM	0	3	9	16	57	94	48	15	0	0	0	0	0	0	242	31-40	151	
8:00 AM	1	7	15	27	79	116	39	8	0	0	0	0	0	0	292	31-40	194	
9:00 AM	1	13	12	42	96	152	66	26	3	0	0	0	0	0	411	31-40	247	
10:00 AM	3	10	14	61	110	127	70	14	0	1	0	0	0	0	410	31-40	236	
11:00 AM	4	12	16	49	131	169	65	19	7	2	0	0	0	0	474	31-40	300	
12:00 PM	9	23	28	59	148	179	69	15	1	0	0	0	0	0	531	31-40	327	
1:00 PM	8	19	31	67	125	158	76	13	0	0	0	0	0	0	497	31-40	283	
2:00 PM	6	13	30	59	135	177	72	27	3	1	0	0	1	0	524	31-40	311	
3:00 PM	6	13	22	50	110	164	82	24	12	0	0	0	0	0	483	31-40	274	
4:00 PM	3	10	17	41	123	176	75	20	3	1	0	0	0	0	469	31-40	299	
5:00 PM	6	9	11	42	91	163	64	18	1	0	1	0	0	0	406	31-40	254	
6:00 PM	1	5	11	23	71	102	49	15	4	2	0	0	0	0	283	31-40	172	
7:00 PM	1	10	11	16	70	99	47	14	3	0	0	0	0	0	271	31-40	169	
8:00 PM	2	3	3	15	58	77	25	11	3	0	0	0	0	0	197	31-40	135	
9:00 PM	1	1	4	12	56	49	16	5	1	1	0	0	0	0	146	31-40	105	
10:00 PM	1	0	2	12	24	37	17	4	0	0	0	0	0	0	97	31-40	61	
11:00 PM	0	1	0	2	20	21	10	2	2	0	0	0	0	0	58	31-40	41	
Day Total	54	156	244	607	1602	2252	968	272	51	10	1	1	1	0	6219	31-40	3853	
Percent	0.9%	2.5%	3.9%	9.8%	25.8%	36.2%	15.6%	4.4%	0.8%	0.2%	0.0%	0.0%	0.0%	0.0%				
ADT 6219																		
AM Peak Volume	11:00 AM	9:00 AM	11:00 AM	10:00 AM	11:00 AM	11:00 AM	10:00 AM	9:00 AM	11:00 AM	11:00 AM	4:00 AM				11:00 AM			
	4	13	16	61	131	169	70	26	7	2	1				474			
PM Peak Volume	12:00 PM	12:00 PM	1:00 PM	1:00 PM	12:00 PM	12:00 PM	3:00 PM	2:00 PM	3:00 PM	6:00 PM	5:00 PM	2:00 PM			12:00 PM			
	9	23	31	67	148	179	82	27	12	2	1	1			531			
Comments:																		

<b>LOCATION:</b> 45770 Conversion <b>SPECIFIC LOCATION:</b> 45770 Conversion <b>CITY/STATE:</b> Oakridge, OR															<b>QC JOB #:</b> 14761214 <b>DIRECTION:</b> EB/WB <b>DATE:</b> Jul 12 2018		
Start Time	1 15	16 20	21 25	26 30	31 35	36 40	41 45	46 50	51 55	56 60	61 65	66 70	71 75	76 999	Total	Pace Speed	Number in Pace
12:00 AM	0	0	0	3	12	13	7	1	1	1	0	0	0	0	38	31-40	25
1:00 AM	0	1	1	1	12	11	9	2	3	0	1	0	0	0	41	31-40	23
2:00 AM	0	0	0	2	9	9	4	1	0	1	1	0	0	0	27	31-40	18
3:00 AM	1	0	1	3	5	17	6	1	0	0	0	0	0	0	34	36-45	23
4:00 AM	0	0	0	4	11	16	10	3	1	0	0	0	0	0	45	31-40	27
5:00 AM	0	0	2	6	15	38	22	4	0	0	0	0	0	0	87	36-45	60
6:00 AM	2	1	1	6	7	30	13	3	0	0	0	0	0	0	63	36-45	42
7:00 AM	0	0	0	0	0	0	0	0	0	0	0	0	0	0	0	1-10	0
8:00 AM	0	0	0	0	0	0	0	0	0	0	0	0	0	0	0	1-10	0
9:00 AM	0	0	0	0	0	0	0	0	0	0	0	0	0	0	0	1-10	0
10:00 AM	0	0	0	0	0	0	0	0	0	0	0	0	0	0	0	1-10	0
11:00 AM	0	0	0	0	0	0	0	0	0	0	0	0	0	0	0	1-10	0
12:00 PM	0	0	0	0	0	0	0	0	0	0	0	0	0	0	0	1-10	0
1:00 PM	0	0	0	0	0	0	0	0	0	0	0	0	0	0	0	1-10	0
2:00 PM	0	0	0	0	0	0	0	0	0	0	0	0	0	0	0	1-10	0
3:00 PM	0	0	0	0	0	0	0	0	0	0	0	0	0	0	0	1-10	0
4:00 PM	0	0	0	0	0	0	0	0	0	0	0	0	0	0	0	1-10	0
5:00 PM	0	0	0	0	0	0	0	0	0	0	0	0	0	0	0	1-10	0
6:00 PM	0	0	0	0	0	0	0	0	0	0	0	0	0	0	0	1-10	0
7:00 PM	0	0	0	0	0	0	0	0	0	0	0	0	0	0	0	1-10	0
8:00 PM	0	0	0	0	0	0	0	0	0	0	0	0	0	0	0	1-10	0
9:00 PM	0	0	0	0	0	0	0	0	0	0	0	0	0	0	0	1-10	0
10:00 PM	0	0	0	0	0	0	0	0	0	0	0	0	0	0	0	1-10	0
11:00 PM	0	0	0	0	0	0	0	0	0	0	0	0	0	0	0	1-10	0
<b>Day Total</b>	3	2	5	25	71	134	71	15	5	2	2	0	0	0	335	31-40	205
<b>Percent</b>	0.9%	0.6%	1.5%	7.5%	21.2%	40.0%	21.2%	4.5%	1.5%	0.6%	0.6%	0.0%	0.0%	0.0%			
<b>ADT</b> 335																	
<b>AM Peak</b> Volume	6:00 AM	1:00 AM	5:00 AM	5:00 AM	5:00 AM	5:00 AM	5:00 AM	5:00 AM	1:00 AM	12:00 AM	1:00 AM	5:00 AM	87				
<b>PM Peak</b> Volume												12:00 PM	0				
<i>Comments:</i>																	

<b>LOCATION:</b> 45770 Conversion														<b>QC JOB #:</b> 14761214			
<b>SPECIFIC LOCATION:</b> 45770 Conversion														<b>DIRECTION:</b> EB/WB			
<b>CITY/STATE:</b> Oakridge, OR														<b>DATE:</b> Jul 10 2018 - Jul 12 2018			
Start Time	1 15	16 20	21 25	26 30	31 35	36 40	41 45	46 50	51 55	56 60	61 65	66 70	71 75	76 999	Total	Pace Speed	Number in Pace
<b>Grand Total</b>	102	321	489	1251	3216	4469	1944	492	96	23	3	2	1	0	12409	31-40	7684
<b>Percent</b>	0.8%	2.6%	3.9%	10.1%	25.9%	36.0%	15.7%	4.0%	0.8%	0.2%	0.0%	0.0%	0.0%	0.0%			
<b>Cumulative Percent</b>	0.8%	3.4%	7.3%	17.4%	43.3%	79.4%	95.0%	99.0%	99.8%	100.0%	100.0%	100.0%	100.0%	100.0%			
<b>ADT 4136</b>															<b>85th Percentile</b> 41 MPH <b>Mean Speed(Average)</b> 35 MPH		
<i>Comments:</i>															<b>Median</b> 35 MPH <b>Mode:</b> 38 MPH		



## Appendix B – 2000 Oakridge TSP Cross Sections



# Arterials

## Minimum (no parking)

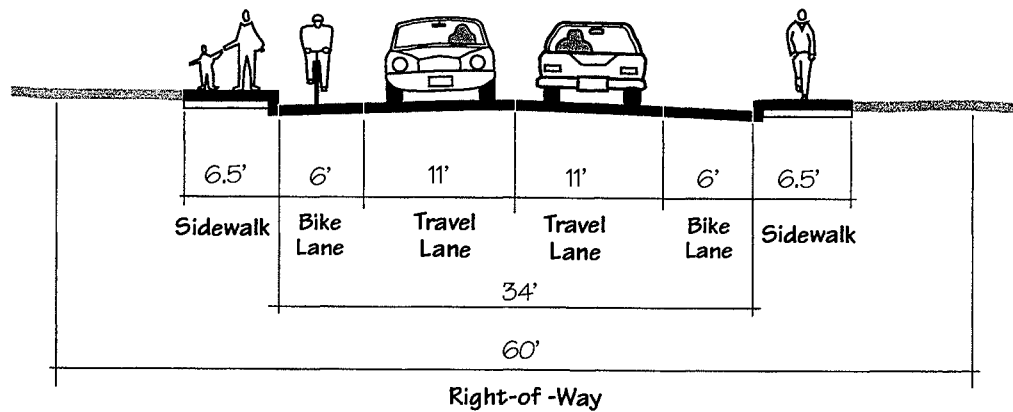

## Maximum (on-street parking allowed)

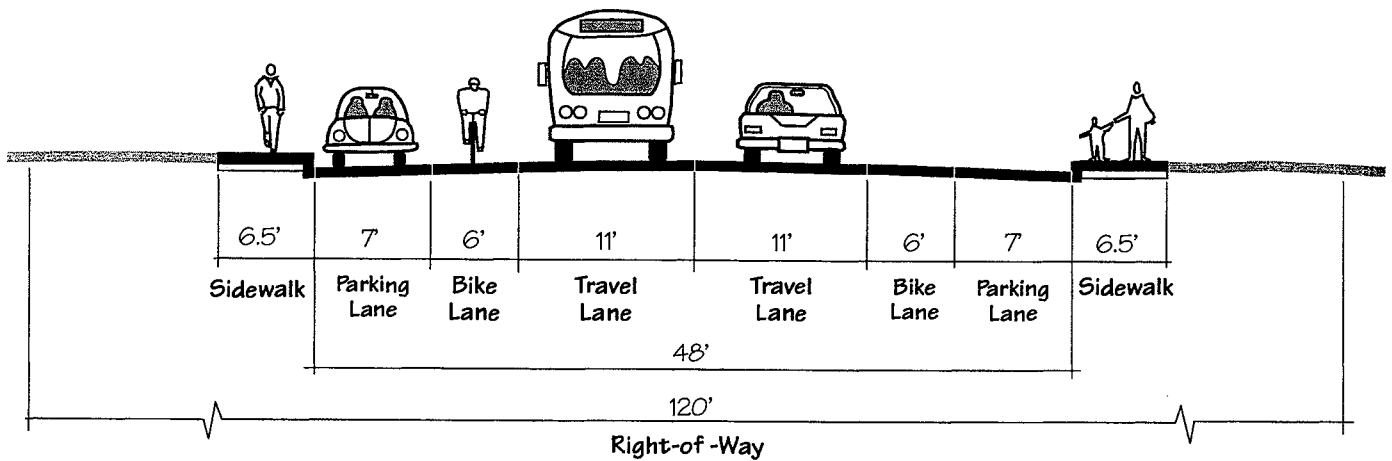

## Typical (with center turn lane)

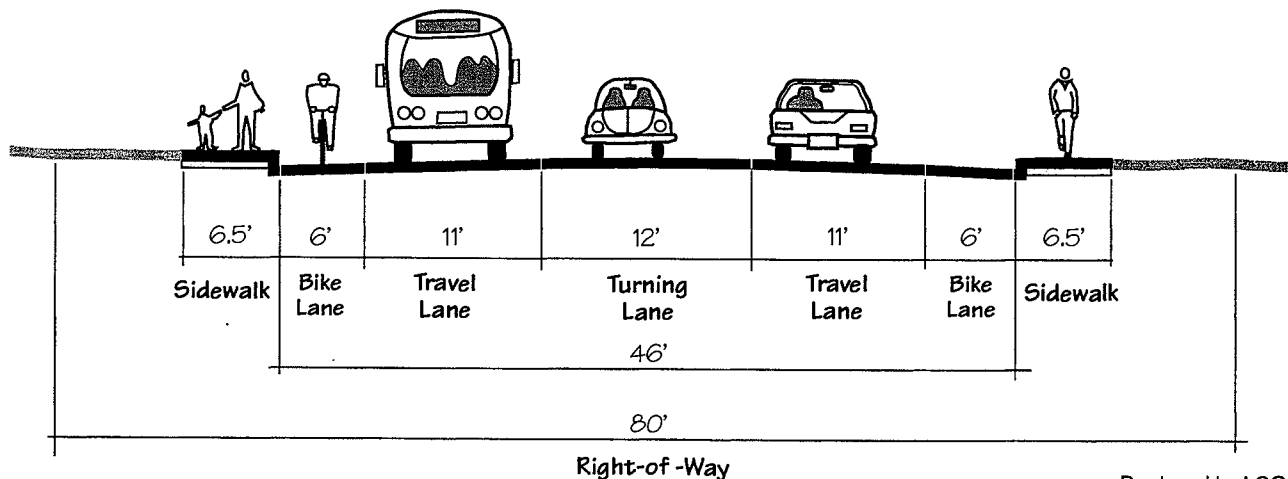

Produced by LCOG, 7/00

Streets, bike lanes, and pedestrian facilities shall conform to the following standards, unless otherwise indicated on a development plan or approved by the Planning Commission by way of variance, exceptions, or feasible alternatives.

**Oakridge Transportation System Plan**  
**Figure 4 - Street Standards**

# Major Collectors

## Minimum (with bike lanes and no parking)

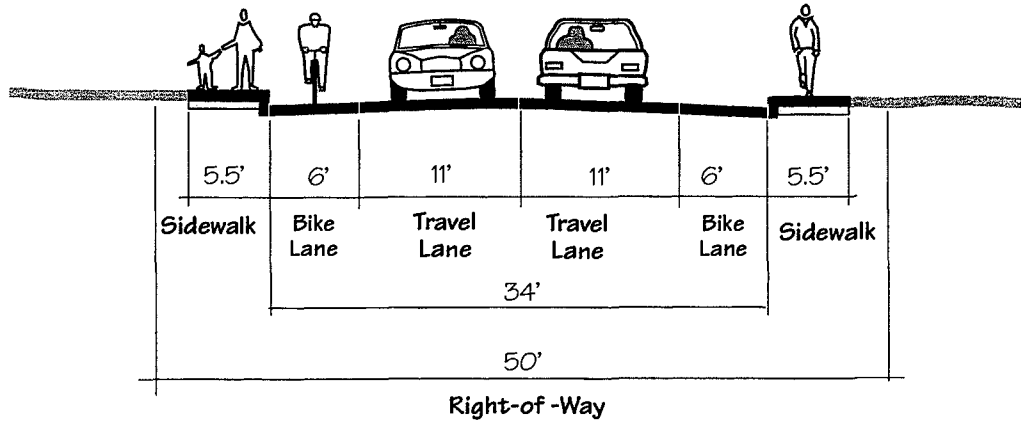

## Maximum (with bike lanes and on-street parking allowed)

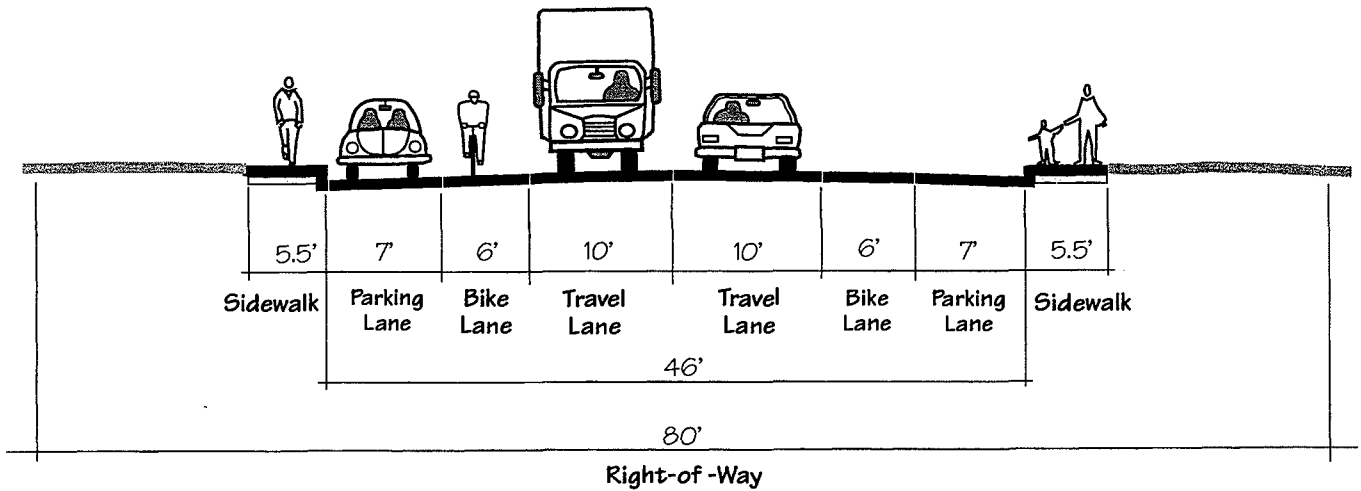

Produced by LCOG, 7/00

Streets, bike lanes, and pedestrian facilities shall conform to the following standards, unless otherwise indicated on a development plan or approved by the Planning Commission by way of variance, exceptions, or feasible alternatives.

**Oakridge Transportatic System Plan**  
**Figure 5 - Street Standards**

# Minor Collectors

## Minimum (with bike lanes\* and no parking)

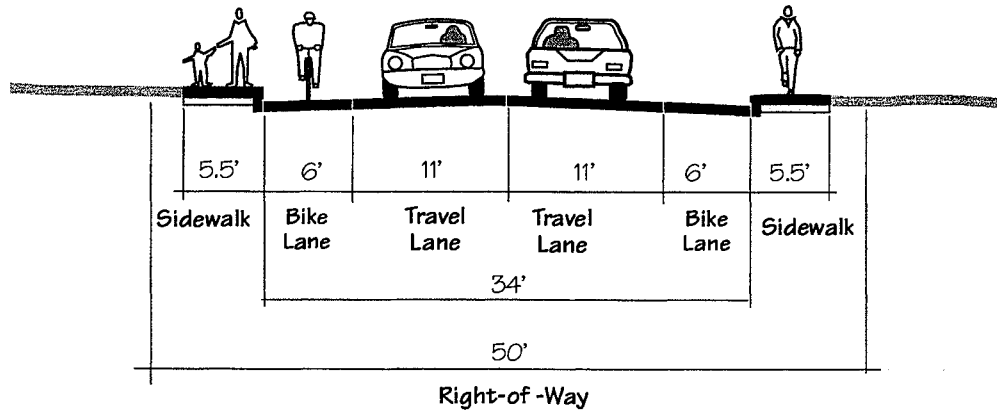

## Maximum (with bike lanes\* and on-street parking allowed)

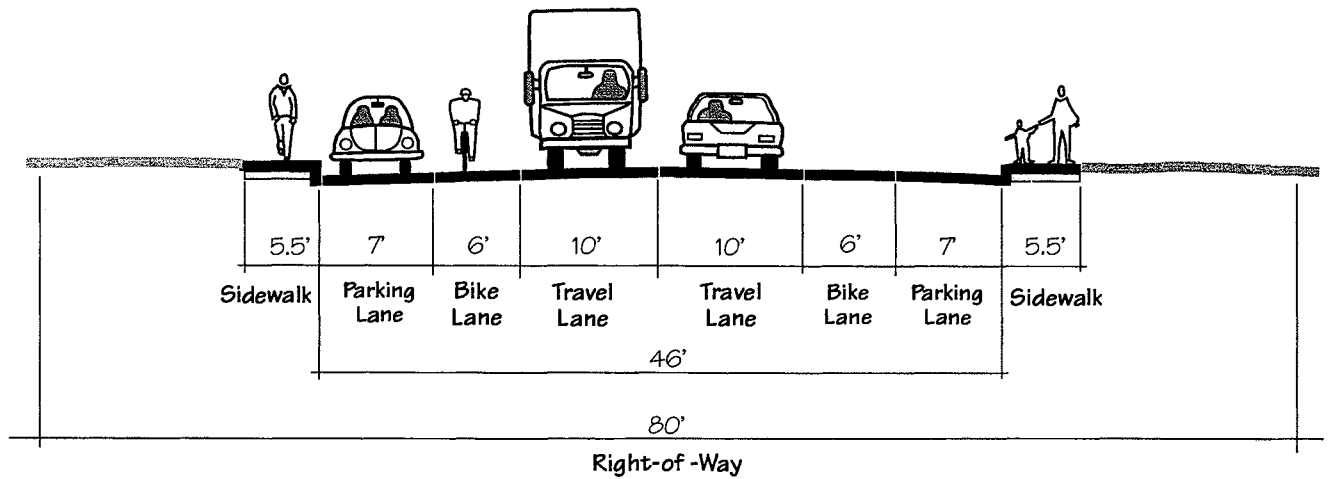

## Typical (without bike lanes)

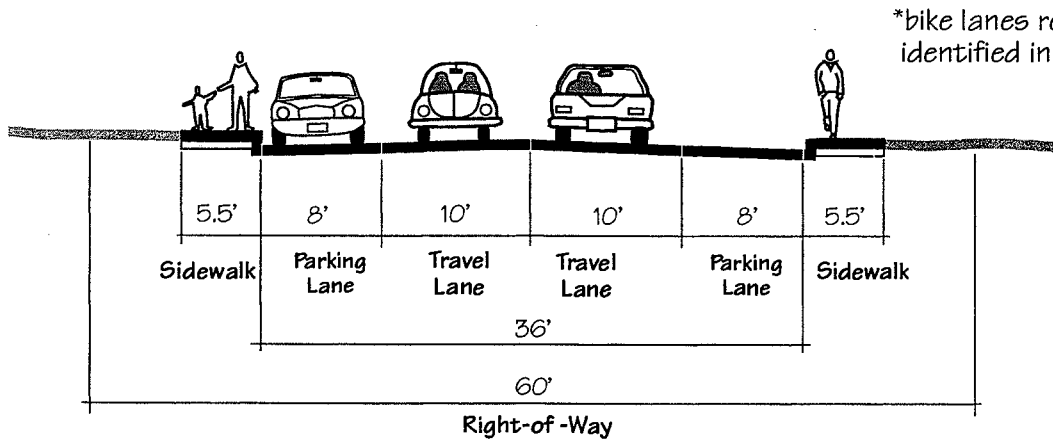

\*bike lanes required only if identified in bicycle plan

Produced by LCOG, 7/00

Streets, bike lanes, and pedestrian facilities shall conform to the following standards, unless otherwise indicated on a development plan or approved by the Planning Commission by way of variance, exceptions, or feasible alternatives.

**Oakridge Transportation System Plan**  
**Figure 6 - Street Standards**

# Local Streets

## Minimum (no parking)

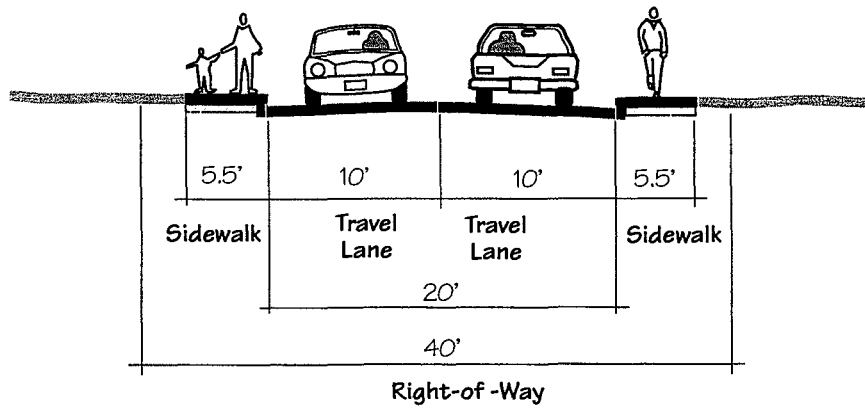

## Maximum (on-street parking)

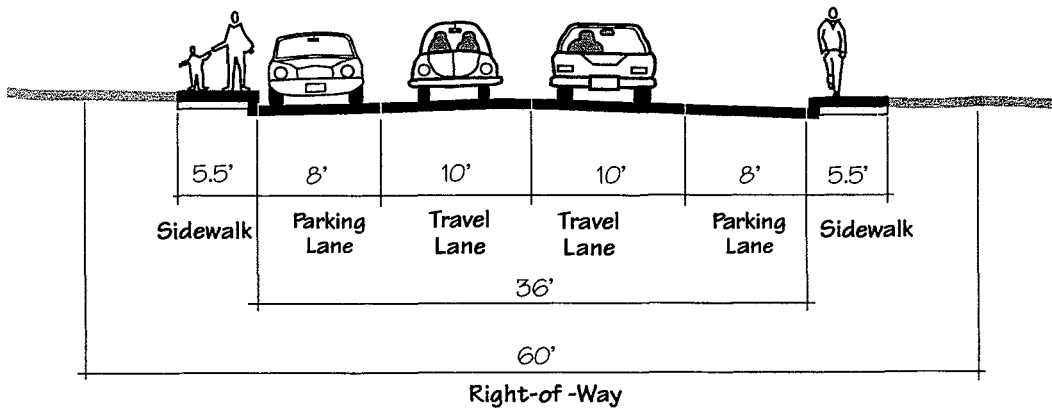

## Typical (on-street parking)

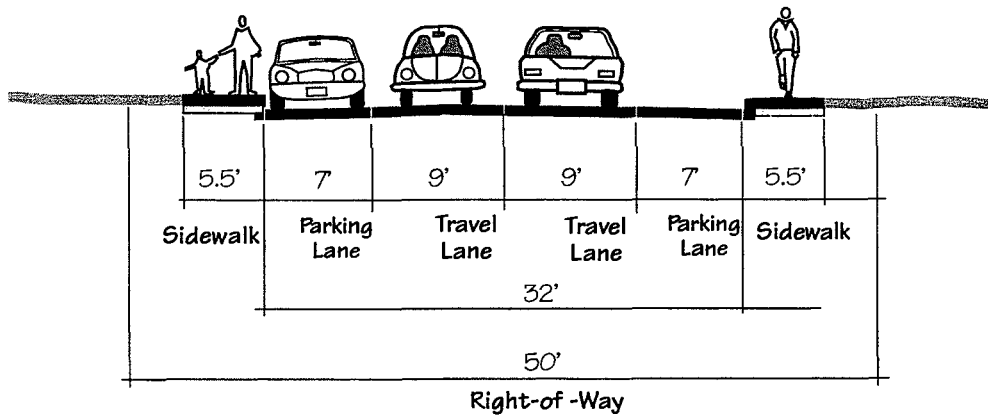

Produced by LCOG, 7/00

Streets, bike lanes, and pedestrian facilities shall conform to the following standards, unless otherwise indicated on a development plan or approved by the Planning Commission by way of variance, exceptions, or feasible alternatives.

**Oakridge Transportation System Plan**  
**Figure 7 - Street Standards**

## Appendix C – Methodology Memorandum

## MEMORANDUM

**Date:** December 14, 2018

Project #: 22477

**To:** Rick Zylstra (City of Oakridge)  
Louis Gomez (City of Oakridge)  
David Helton (Oregon Department of Transportation)

**From:** Ashleigh Ludwig, PE, Marc Butorac, PE and Jacki Gulczynski (Kittelison & Associates, Inc.)

**Project:** City of Oakridge Transportation System Plan Update

**Subject:** Transportation Analysis Methodology and Assumptions Memorandum

---

## MEMORANDUM OVERVIEW

---

This memorandum documents the methodology and assumptions that will be used to complete the existing and future transportation conditions and alternative analyses for the City of Oakridge Transportation System Plan (TSP) update. The methodology and assumptions included in this memorandum are based on guidance provided in the Oregon Department of Transportation (ODOT) Transportation System Plan Guidelines (Reference 1), the ODOT Analysis Procedures Manual (APM – Reference 2), and direction provided by the City of Oakridge and ODOT staff. The methodology and assumptions described in this memorandum will be used to help identify potential gaps and deficiencies in the transportation system, including:

- ▶ Traffic operations at the study intersections under existing and future traffic conditions,
- ▶ Traffic safety at the study intersections and along study area roadways,
- ▶ Gaps and deficiencies in the bicycle and pedestrian network,
- ▶ Gaps and deficiencies in the transit service (service frequency, hours, coverage, etc.), and
- ▶ Gaps and deficiencies in other travel modes.

This information will serve as a baseline for identifying a comprehensive list of needs (gaps and deficiencies) to be addressed as part of the TSP update. It will also serve as a baseline for identifying and evaluating potential solutions to address the needs and to develop a prioritized list of improvements for the TSP update.

## 01 | STUDY AREA

### STUDY INTERSECTIONS

Figure 1 identifies the study area and study intersections and segments. Two-hour weekday p.m. peak hour traffic counts (4:00 - 6:00 p.m.) were collected by ODOT on July 10, 2018 and include vehicle turning movements, pedestrian volumes, bicycle volumes, and truck volumes. Two-hour weekday afternoon (2:00 – 4:00 p.m.) counts will be conducted by ODOT during a typical weekday in October 2018 at the intersection of W 1<sup>st</sup> Street/Crestview Street, based on the proximity to the elementary, middle, and high schools.

The study intersections are as follows:

- OR 58 / River Road / W 2<sup>nd</sup> Street
- OR 58 / Rainbow Road
- OR 58 / Crestview Street
- OR 58 / Hills Street
- E 2<sup>nd</sup> Street / Westfir-Oakridge Road
- Westfir-Oakridge Road / High Prairie Road
- W 1<sup>st</sup> Street / Crestview Street<sup>1</sup>

In addition to the turning movement counts, 48-hour tube counts were collected at the following locations between July 10<sup>th</sup> and July 12<sup>th</sup> in 2018:

- OR 58 (Willamette Highway) – Milepost 35.50 (east of Crestview Street)
- OR 58 (Willamette Highway) – Milepost 35.40 (west of Crestview Street)
- Fish Hatchery Road – south of Union Pacific Rail Crossing

Additionally, a 24-hour tube count was collected at Beech Street – south of Union Pacific Rail Crossing on July 10<sup>th</sup>, 2018.

The data collected includes vehicle speed, classification, and total volume. Both the turning movement counts and the tube counts were collected consistent with Task 2.5.ii of the ODOT scope.

---

<sup>1</sup> This location will be analyzed separately (during the a.m. and afternoon peak hours rather than the p.m. peak hour) to account for the start and dismal periods of the school.

H:\2222477 - Oakridge TSP Update\GIS\Memo 4 - System Conditions and Deficiencies\Figure 1 - Study Area.mxd - aludwig - 2:57 PM 12/14/2018

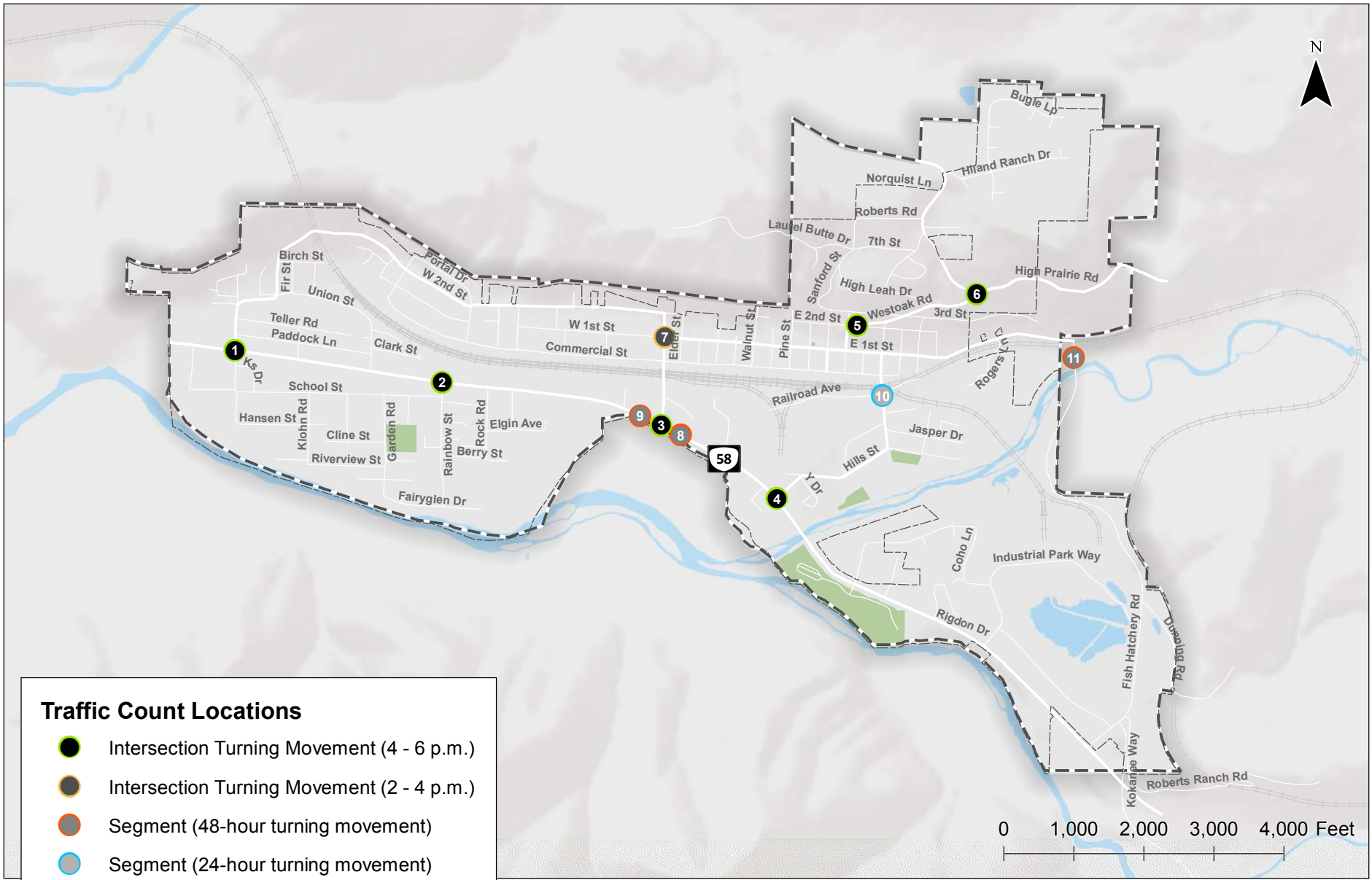

**Traffic Count Locations**

- Intersection Turning Movement (4 - 6 p.m.)
- Intersection Turning Movement (2 - 4 p.m.)
- Segment (48-hour turning movement)
- Segment (24-hour turning movement)
- Oakridge City Boundary
- Urban Growth Boundary

**Study Area  
Oakridge, Oregon**

**Figure  
1**



## TRAFFIC COUNTS

Turning movement counts were conducted by ODOT at the majority of the study intersections and segments in July 2018. The counts were conducted on a typical mid-week day during the summer season while school was out of session. Intersection counts were conducted over a 2-hour period between 4:00 p.m. and 6:00 p.m. Intersection counts include the total number of pedestrians, bicyclists, and motor vehicles that entered the intersections in 15-minute intervals throughout the study periods.

Segment data was collected over a 48-hour period from 4:30 a.m. on Tuesday July 10<sup>th</sup> to 4:30 a.m. on Thursday July 12<sup>th</sup>. Segment data has been classified by directional volume, speed, and vehicle classification. *The traffic count worksheets are provided in Attachment A.*

## PEAK HOUR DEVELOPMENT

Individual and system peak hours were evaluated at the study intersections. Of the six study intersections, five were reported as having a peak hour period between 4:00-5:00 p.m. The Westfir-Oakridge Road/E 2<sup>nd</sup> Street intersection peaked between 4:45 and 5:45 p.m. Table 1 illustrates the individual peak hours of each study intersection.

**Table 1. Study Intersection Individual Peak Hour**

Map ID	Intersection	Individual Peak Hour	System Peak Hour
1	W 2 <sup>nd</sup> Street/River Road/OR 58	4:00-5:00 p.m.	4:00-5:00 p.m.
2	Rainbow Road/OR 58	4:00-5:00 p.m.	4:00-5:00 p.m.
3	Crestview Street/OR 58	4:00-5:00 p.m.	4:00-5:00 p.m.
4	Hill Street/OR 58	4:00-5:00 p.m.	4:00-5:00 p.m.
5	Westfir-Oakridge Road/E 2 <sup>nd</sup> Street	4:45-5:45 p.m.	4:00-5:00 p.m.
6	Westfir-Oakridge Road/High Prairie Road	4:00-5:00 p.m.	4:00-5:00 p.m.

The Total entering Vehicles (TEV) at Westfir-Oakridge Road/E 2<sup>nd</sup> Street was less than one percent higher during the individual peak compared to the system peak. Therefore, a system peak was applied to all of the study intersections with the exception of W 1<sup>st</sup> Street/Crestview Street, where the school peak period (during the weekday afternoon time periods) will be determined and analyzed.

## SEASONAL ADJUSTMENT FACTOR

Thirtieth (30<sup>th</sup>) highest hour volumes (30 HV) for the TSP update will be developed based on the traffic counts collected at the study intersections and the application of seasonal adjustment factors consistent with the methodology identified in the APM. The APM provides three methods for identifying seasonal adjustment factors for highway traffic volumes. All three methods utilize information provided by Automatic Traffic Recorders (ATRs) positioned in select locations throughout the State Highway System that collect traffic data 24-hours a day, 365 days a year.

The On-Site ATR method requires that the ATR be located within or near the project area. If the ATR is located outside the project area, there should be no major intersections between the ATR and the project area, and the Average Annual Daily Traffic (AADT) collected by the ATR must be within 10 percent of the AADT within the project area. There is one ATR located on OR 58 near the City of Oakridge. This station (ATR #20-017) is located approximately 0.25 miles east of Fish Hatchery Road. The ADT at the in ATR station is more than 10 percent less than the ADT in the project area.

Since the On-site ADT is more than 10 percent less than that study area, the APM recommends using the ATR Characteristic Table Method. After analyzing the table, there are no ATR locations with a summer seasonal traffic trend and four travel lanes with an ADT within 10-percent of collected counts on OR 58. The most comparable location was Interstate-84 in Baker County. Given the variation in both ADT and highway classification, the ATR Characteristics Table was not recommended for use of seasonal adjustment factors in Oakridge.

As directed by the APM, if the On-Site ATR and Characteristic Table do not apply, the Seasonal Trend Table should be used to develop a season adjustment factor. The On-site ATR is classified in the ATR Characteristics Table as a Recreational Summer Location. The Seasonal Trends Table separates each month by two periods – the 1<sup>st</sup> of the month and the 15<sup>th</sup> of the month. If counts were collected prior a date in the table, they are classified in the previous date category (i.e. January 20<sup>th</sup> would be classified under the January 15<sup>th</sup> category). Based on the table, the peak recreational summer period is July 15<sup>th</sup>. The traffic counts were collected on July 10<sup>th</sup>. Therefore, a seasonal adjustment must be applied to the counts. Table 2 shows the table values from the most recent APM Seasonal Trend Table. Based on the table results, a seasonal adjustment factor of 1.08 will be applied to study intersections. *Attachment B includes the Seasonal Trend Table (Updated in August 2018).*

**Table 2. Seasonal Adjustment Factor Calculations – Seasonal Trend Table Data**

Trend	July 1 <sup>st</sup> (Count Period)	July 15 <sup>th</sup> (Peak Period)	Seasonal Adjustment
Recreational Summer	0.7650	0.7071	<b>1.08</b>

## FORECAST TRAFFIC VOLUMES

The TSP horizon year will be 2040. Future year 2040 traffic volumes will be developed using the Lane County of Governments (LCOG) EMME/2 travel forecast model, as discussed in the following sections. Two additional methods were evaluated as possible methods of forecasting traffic volumes but were ultimately found to be inappropriate methods. These are also discussed below.

### Historical Trends Method Using ODOT Future Volumes Tables

The ODOT APM recommends using the historical trends method, which relies on traffic volumes from previous years to develop a growth pattern for use in projected future volumes. ODOT maintains Future Volumes Tables that summarize current and future year traffic volumes for state roadways throughout the state. These forecasts provide a base year 2016 and forecast year 2036. The ODOT APM guidance states that data with an R-squared value (RSQ, a measure of fit) of less than 0.75 should not be used when calculating future growth. All of the traffic volume data points along OR 58 in Oakridge, including the ATR #20-017 station, exhibit RSQ values less than 0.55. In addition, the resulting annual average growth rate based on these locations is 0.08 percent per year. The low RSQ values of the volume projections in the Future Volumes Tables, along with the unreasonably low annual growth rates resulting from this data, indicates that the future volume tables are not a reliable projection of the future growth on OR 58 near or within the City limits.

### Historical Trends Method Using Historic Count Data

The City of Oakridge does not collect traffic counts on a regular basis; the only traffic volume data the City has available is data collected by ODOT for the TSP update or other projects. The project team used traffic volume data collected in 1998 and documented in the City's 2000 TSP to compare against counts conducted in 2018 to develop annual growth rates. The comparison of 1998 TSP traffic volumes on OR 58 with those collected at similar locations in 2018 (after seasonal adjustment factors were applied) showed a decrease in total traffic volumes between 1998 and 2018. The project team felt that projecting zero growth or a decline in traffic volumes is not reasonable for the City, which is experiencing an increase in recreational traffic and serves as an important statewide connection. Therefore, this method was determined to be unreliable for developing future traffic forecasts.

### Future Projections Using Travel Demand Model

The City of Oakridge has a travel demand model that is owned by the Lane Council of Governments (LCOG). The model accounts for expected growth throughout the region and is coordinated with statewide population and employment forecasts. The model was last updated in the mid-2000s with a horizon year of 2025. Although the model has not been maintained in recent years, there have not been major developments or changes in land use that

would substantially modify traffic patterns since the model was developed. Therefore, the travel demand model was determined to be the most appropriate method available for calculating future volume projections.

Growth factors identified in Table 3 will be applied to ODOT and City study intersections and study segments. Several locations along OR 58 were averaged to develop a growth rate along the corridor. Additionally, roadway facilities throughout the city were averaged to develop a rate to be applied to City and County roads. As shown, the average annual growth rate for ODOT and City facilities was 1.19% and 0.44%, respectively. To provide a conservative approach, a 1.25% growth rate will be applied to ODOT facilities, and a 0.50% growth rate will be applied to City facilities. Population growth projections developed for the County<sup>2</sup> indicate the City of Oakridge is anticipated to grow by approximately 0.2% per year from 2015 to 2065. The traffic volume projects appear to provide a reasonable, conservative estimate of future volume growth relative to the population growth forecasts.

**Table 3. Growth Factors**

Location	Direction	2002 Model Volume	2025 Model Volume	20-Year Growth Factor	Annual Growth Rate
OR 58 (West of Crestview Street)	Eastbound	4830	5919	1.23	0.98%
	Westbound	4861	5989	1.23	1.05%
OR 58 (East of Crestview Street)	Eastbound	3566	4711	1.32	1.46%
	Westbound	3544	4732	1.34	1.52%
OR 58 (East of 2 <sup>nd</sup> Street)	Eastbound	3803	4670	1.23	1.04%
	Westbound	3805	4690	1.23	1.06%
<b>ODOT Facility Average</b>				<b>1.26</b>	<b>1.19%</b>
Hill Street (North of OR 58)	Northbound	1098	1324	1.21	0.89%
	Southbound	1088	1300	1.19	0.85%
Commercial Street (East of Crestview Street)	Eastbound	64	68	1.06	0.27%
	Westbound	52	54	1.04	0.17%
2 <sup>nd</sup> Street (North of OR 58)	Northbound	478	501	1.05	0.21%
	Southbound	453	479	1.06	0.25%
<b>City Facility Average</b>				<b>1.10</b>	<b>0.44%</b>

## 02 | INTERSECTION OPERATIONAL STANDARDS

### ODOT FACILITIES

ODOT uses volume-to-capacity (V/C) ratios to assess intersection operations. Table 6 of the *Oregon Highway Plan* (OHP – Reference 3) and Table 10-2 of the *Oregon Highway Design Manual* (HDM – Reference 4) provide maximum volume-to-capacity ratios for all signalized and unsignalized intersections located outside the Portland metropolitan area. The OHP ratios are used to evaluate existing and future no-build conditions, while the HDM ratios are used in the creation of future TSP alternatives which involve projects along state highways. OR 58 is the only ODOT controlled facility within the study area. OR 58 is designated as an OHP Statewide Highway, an OHP Freight Route, and has a federal functional classification of Other Rural Principal Arterial. The posted speed limit of OR 58 within the city limits (at all TSP study intersections) is 35 miles per hour (mph). It is noted that a speed transition zone is located within city limits where the westbound speed limit is reduces from 55mph to 35mph. This transition zone is located between Industrial Park Way and Hyland Lane.

<sup>2</sup> Coordinated Population Forecast for Lane County, Portland Research Center, Portland State University, 2015

All side street roadways at intersections on OR 58 are City roadways and therefore classified under ODOT District Highway/Local Interest Roads when applying the performance targets from the OHP. The speed limits on these roads is less than 35 mph.

As the City of Oakridge is not within a Metropolitan Planning Organization (MPO) area, the Non-MPO performance targets were applied to all of the study intersections. Table 4 summarizes the volume-to-capacity (v/c) ratios that will be used to identify the existing and potential future operational issues at the ODOT study intersections.

- For unsignalized intersections, the OHP indicates that the v/c ratios apply to the corresponding approach to the intersection. In addition, Chapter 12 of the ODOT Analysis and Procedures Manual (APM), page 12-11, indicates that the v/c ratio for the controlling movement often controls the intersection performance and is therefore the one reported and evaluated against the mobility standard for two-way stop-controlled intersections. Therefore, the v/c ratio will be reported for the critical lane group at two-way stop-controlled (TWSC) intersections.
- For signalized intersections, OHP 1F.1 indicates that the “overall intersection v/c ratio is expected to meet or not to exceed” the v/c ratio. The mobility target for a signalized intersection is identified as the highest order, most restrictive approach (i.e. at the signalized intersection of a state highway and a local road, the mobility target of the state highway is selected as the overall intersection v/c ration threshold).

Map ID	Intersection	Traffic Control	OHP Mobility Target (v/c ratio)	HDM Standard (v/c ratio)
1	River Road/OR 58	TWSC	0.95 N-S/0.85 E-W	0.80 N-S/0.70 E-W
2	Rainbow Road/OR 58	TWSC	0.95 N-S/0.85 E-W	0.80 N-S/0.70 E-W
3	Crestview Street/OR 58	Traffic Signal	0.85 (overall intersection)	0.70 (overall intersection)
4	Hill Street/OR 58	TWSC	0.95 N-S/0.85 E-W	0.80 N-S/0.70 E-W

## COUNTY FACILITIES

While Westfir-Oakridge Road is owned by the County, the study intersections are within the City of Oakridge Urban Growth Boundary (UGB). The County holds jurisdictional responsibility over the maintenance and mobility standards for County roads within the UGB.

The County uses Level of Service (LOS) and Volume to Capacity (v/c) ratios to assess intersection operations. For intersections within the City's UGB, the County's current TSP sets a maximum LOS Standard of "E" and a v/c ratio no greater than 0.95 as the performance standards. The TSP does not specify whether the standards should be applied to the overall intersection or critical approach. Therefore, the standards will be applied to the critical approach. For intersections outside the City's UGB, the performance standards are a maximum LOS of "D" and a v/c ratio no greater than 0.80. Table 5 summarizes the LOS standards that will be used to identify existing and potential future operational issues at the County study intersections.

Map ID	Intersection	Traffic Control	Mobility Standard
5	Westfir-Oakridge Road/E 2 <sup>nd</sup> Street	TWSC	LOS E, v/c=0.95
6	Westfir-Oakridge Road/High Prairie Road	TWSC	LOS E, v/c=0.95

Traffic operations at the study intersections will be evaluated based on the mobility targets and standards shown in Tables 4 and 5. Potential solutions will be identified and evaluated for the study intersections that are found to exceed the mobility targets and standards under existing and future traffic conditions.

## CITY FACILITIES

The City does not have mobility standards for their roadways. Therefore, the County mobility standards will be applied to the intersection of Crestview Street/E 1<sup>st</sup> Street to assess the existing and future operations. Table 6 indicates the mobility standards that will be applied to the study intersection within the City's jurisdiction.

**Table 6. City Mobility Standards**

Map ID	Intersection	Traffic Control	Mobility Standard
7	Crestview Street/E 1 <sup>st</sup> Street	TWSC	LOS E, v/c=0.95

## 03 | ANALYSIS ASSUMPTIONS

### ANALYSIS MODEL PARAMETERS

The bullets below identify the specific sources of data and methodologies proposed to conduct the operational analyses. Analyses of all state facilities will be conducted according to the APM, unless otherwise agreed upon by the City and ODOT.

1. Intersection/Roadway Geometry (lane numbers and arrangements, cross-section elements, signal phasing, etc.) will be collected through aerial photography and confirmed through a site visit. The analysis models will be built on scaled roadway line work from GIS or aerial photography.
2. Operational Data (such as posted speeds, intersection control, parking, transit stops, rail crossings, right-turn on red, etc.) will be collected through a site visit. Data will be reviewed and supplemented by available GIS data, traffic count DVDs, aeriels, and photos.
3. Peak Hour Factors (PHF) will be calculated for each intersection and applied to the existing conditions analyses. Per the APM, PHFs of 0.95 will be used for the year 2040 analysis for high-order facilities (arterials), with 0.90 applied to medium-order facilities (collectors) and 0.85 applied to local roads. If the existing PHF is greater than these default future values, the existing PHF will be applied.
4. Traffic Volume development is described above.
5. Traffic Operations
  - a. The Highway Capacity Manual 6<sup>th</sup> Edition (HCM 6) methodology will be used to analyze traffic operations at all the study intersections.
  - b. The existing and future no-build traffic operations analyses will use Synchro 10 software using HCM 6 reports for all two-way stop-controlled intersections. Level-of-service, delay, and volume-to-capacity ratios will be reported for the critical movement at each of the study intersections regardless of roadway jurisdiction. The existing and future no-build traffic operations analysis for the signalized intersection will use Synchro 10 software using HCM 6 reports. In addition to performance metrics for the critical approach, the overall intersection LOS, delay, and v/c ratios will be reported.
  - c. Queuing analysis methodology will be based on Synchro 95<sup>th</sup> percentile queue lengths. Microsimulation is not proposed as part of this long-range planning effort.

## TRAFFIC ANALYSIS SOFTWARE AND INPUT ASSUMPTIONS

Synchro 10 software will be used for the intersection analysis. The reported results will be the critical approach level of service, delay, and v/c ratios generated by the HCM report. Analysis assumptions are listed in Table 6.

**Table 6. Synchro Operations Parameters/Assumptions**

Arterial Intersection Parameters	Existing Conditions
Peak Hour Factor	From traffic counts
Conflicting Bikes and Pedestrian per Hour	From traffic counts, as available
Area Type	Other
Ideal Saturation Flow Rate (for all movements)	1,750 passenger cars per hour green per lane
Lane Width	12 feet unless field observations suggest otherwise
Percent Heavy Vehicles	From traffic counts by movement, as available
Percent Grade	Estimated based on field observations
95 <sup>th</sup> percentile vehicle queues	Synchro 10 summary output

## 04 | MULTI-MODAL AND CRASH ANALYSIS

### MULTI-MODAL

Per the scope, the non-automobile transportation analysis will include a review of collector and arterial roadways to identify deficiencies (availability of sidewalks and bicycle lanes, and gaps in primary routes) based on available GIS data, field observations, and online mapping. A qualitative analysis will be completed for pedestrian, bicycle, and transit mobility. This will include inventory of existing facilities and future planned improvements per the City's Comprehensive Plan, growth projections, and development of planned public facilities.

A Bicycle and Pedestrian Level of Traffic Stress analysis will not be completed as part of the TSP; however, the qualitative assessment will include:

- ▶ Availability of sidewalks and bicycle lanes
- ▶ General condition of existing sidewalks and bicycle lanes
- ▶ Gaps in primary routes
- ▶ High risk crossing locations

### CRASH

The most recent five years (2012 through 2016) of reported crash data will be reviewed at the study intersections and study segments. Reported crash data will be obtained from ODOT's crash database. According to section 4.3.1 of the AMP, the top 5% and 10% Safety Priority Index System (SPIS) sites on OR 58 will be identified and further analyzed as well. The data will be analyzed for a variety of factors including crash type, severity, general conditions, and location to identify potential crash patterns or anomalies. Any issues that are identified through the overall review at the City, corridor/segment, and intersection level will be summarized. Summaries for fatal, serious injury crashes and crashes involving pedestrians and bicyclists will also be provided.

Intersection crash rates will be calculated and compared to statewide 90<sup>th</sup> percentile crash rates for similar intersection types to determine which intersections have crash rates higher than similar facilities. Given the limited number of study intersections to be studied, calculation of a critical crash rate based on the Highway Safety Manual methodology is not a reliable method for identifying a safety performance threshold. Therefore, we will use the

established crash rate performance threshold based on the 90<sup>th</sup> percentile crash rates for statewide urban intersections by traffic control type as documented in Exhibit 4-1 of the APM. Crash patterns and potential countermeasures/safety improvements will be identified and presented at intersections that exceed the statewide crash rate performance threshold.

## REFERENCES

1. Oregon Department of Transportation. Transportation System Plan Guidelines, 2008.
2. Oregon Department of Transportation. Analysis Procedures Manual, 2018.
3. Oregon Department of Transportation. Oregon Highway Plan, 2015.
4. Oregon Department of Transportation. Highway Design Manual, 2012.

## REFERENCES

Attachment A: Traffic Count Sheets

Attachment B: Seasonal Trend Table

---

Attachment A: Traffic Count Sheets



# Intersection #1: OR 58 & River Road

Type of peak hour being reported: Intersection Peak

Method for determining peak hour: Total Entering Volume

**LOCATION:** 45774 -- Conversion  
**CITY/STATE:** Oakridge, OR

**QC JOB #:** 14761202  
**DATE:** Tue, Jul 10 2018

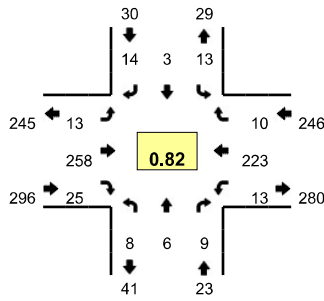

**Peak-Hour: 4:00 PM -- 5:00 PM**  
**Peak 15-Min: 4:00 PM -- 4:15 PM**

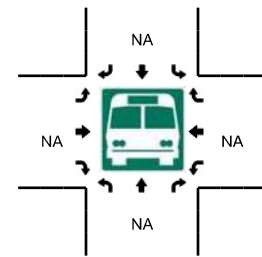
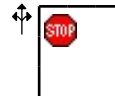
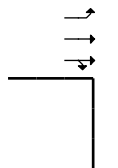
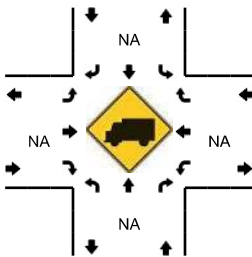
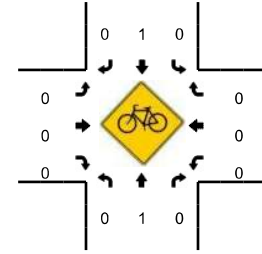
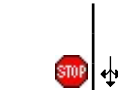
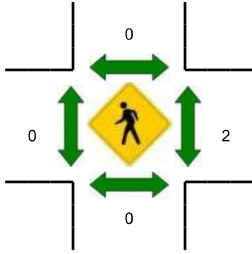
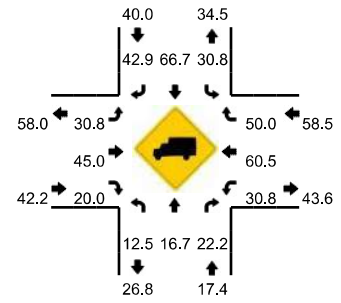

15-Min Count Period Beginning At	45774 (Northbound)				45774 (Southbound)				Conversion (Eastbound)				Conversion (Westbound)				Total	Hourly Totals
	Left	Thru	Right	U	Left	Thru	Right	U	Left	Thru	Right	U	Left	Thru	Right	U		
4:00 PM	1	2	1	0	1	1	3	0	0	90	6	0	6	68	3	0	182	
4:15 PM	3	2	0	0	6	0	6	0	5	59	5	0	4	61	3	0	154	
4:30 PM	1	2	2	0	2	1	2	0	4	55	9	0	1	54	1	0	134	
4:45 PM	3	0	6	0	4	1	3	0	4	54	5	0	2	40	3	0	125	595
5:00 PM	1	0	6	0	2	0	2	0	4	61	4	0	3	68	2	0	153	566
5:15 PM	4	0	6	0	0	1	2	0	8	65	0	0	0	47	2	0	135	547
5:30 PM	1	4	4	0	1	0	0	0	7	78	1	0	3	52	3	0	154	567
5:45 PM	2	1	2	0	2	1	2	0	10	50	8	0	3	39	3	0	123	565
Peak 15-Min Flowrates	Northbound				Southbound				Eastbound				Westbound				Total	
All Vehicles	4	8	4	0	4	4	12	0	0	360	24	0	24	272	12	0	728	
Heavy Trucks	0	0	4		4	4	8		0	144	4		12	248	4		432	
Pedestrians		0				0				0				0			0	
Bicycles	0	0	0		0	0	0		0	0	0		0	0	0		0	
Railroad																		
Stopped Buses																		

Comments:

# Intersection #2: OR 58 & Rainbow Road

Type of peak hour being reported: Intersection Peak

Method for determining peak hour: Total Entering Volume

**LOCATION:** 45775 -- Conversion  
**CITY/STATE:** Oakridge, OR

**QC JOB #:** 14761203  
**DATE:** Tue, Jul 10 2018

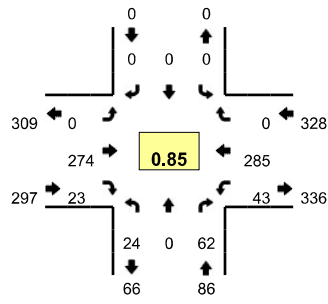

**Peak-Hour: 4:00 PM -- 5:00 PM**  
**Peak 15-Min: 4:00 PM -- 4:15 PM**

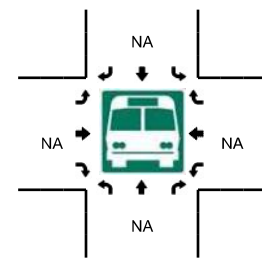
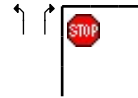
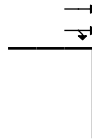
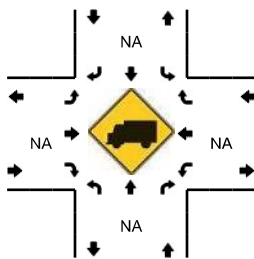
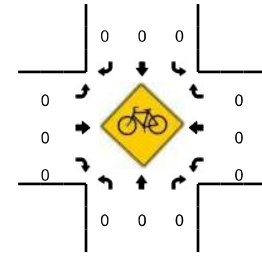
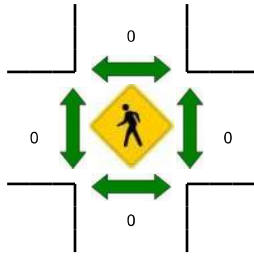
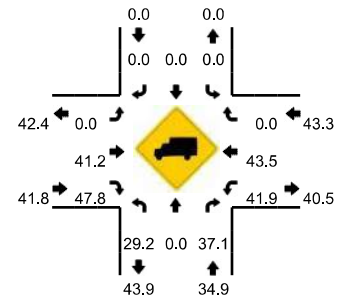

15-Min Count Period Beginning At	45775 (Northbound)				45775 (Southbound)				Conversion (Eastbound)				Conversion (Westbound)				Total	Hourly Totals
	Left	Thru	Right	U	Left	Thru	Right	U	Left	Thru	Right	U	Left	Thru	Right	U		
4:00 PM	10	0	15	0	0	0	0	0	0	85	11	0	11	77	0	0	209	
4:15 PM	5	0	20	0	0	0	0	0	0	62	5	0	14	73	0	0	179	
4:30 PM	3	0	9	0	0	0	0	0	0	70	3	0	11	70	0	0	166	
4:45 PM	6	0	18	0	0	0	0	0	0	57	4	0	7	65	0	0	157	711
5:00 PM	4	0	11	0	0	0	0	0	0	70	11	0	11	68	0	0	175	677
5:15 PM	4	0	12	0	0	0	0	0	0	70	4	0	16	64	0	0	170	668
5:30 PM	4	0	4	0	0	0	0	0	0	82	7	0	18	50	0	0	165	667
5:45 PM	8	0	2	0	0	0	0	0	0	58	1	0	45	47	0	0	161	671

Peak 15-Min Flowrates	Northbound				Southbound				Eastbound				Westbound				Total
	Left	Thru	Right	U	Left	Thru	Right	U	Left	Thru	Right	U	Left	Thru	Right	U	
All Vehicles	40	0	60	0	0	0	0	0	0	340	44	0	44	308	0	0	836
Heavy Trucks	16	0	24	0	0	0	0	0	0	144	20	0	12	124	0	0	340
Pedestrians	0	0	0	0	0	0	0	0	0	0	0	0	0	0	0	0	0
Bicycles	0	0	0	0	0	0	0	0	0	0	0	0	0	0	0	0	0
Railroad																	
Stopped Buses																	

Comments:

# Intersection #3: OR 58 & Crestview Street

Type of peak hour being reported: Intersection Peak

Method for determining peak hour: Total Entering Volume

**LOCATION:** 45773 -- Conversion  
**CITY/STATE:** Oakridge, OR

**QC JOB #:** 14761201  
**DATE:** Tue, Jul 10 2018

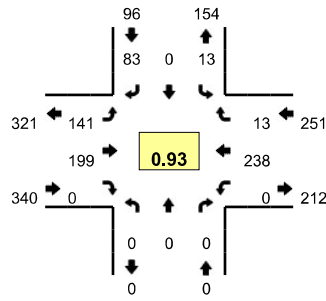

**Peak-Hour: 4:00 PM -- 5:00 PM**  
**Peak 15-Min: 4:15 PM -- 4:30 PM**

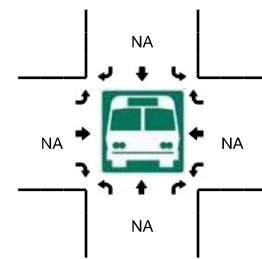
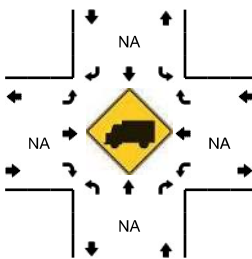
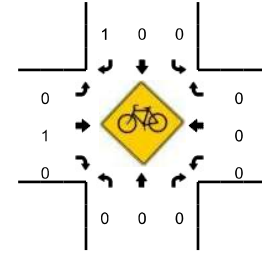
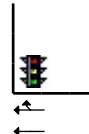
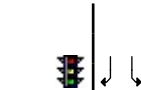
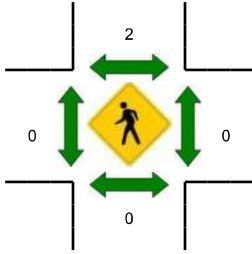
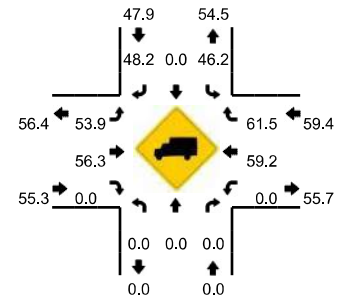

15-Min Count Period Beginning At	45773 (Northbound)				45773 (Southbound)				Conversion (Eastbound)				Conversion (Westbound)				Total	Hourly Totals
	Left	Thru	Right	U	Left	Thru	Right	U	Left	Thru	Right	U	Left	Thru	Right	U		
4:00 PM	0	0	0	0	2	0	22	0	32	48	0	0	0	73	5	0	182	
4:15 PM	0	0	0	0	6	0	27	0	44	50	0	0	0	54	4	0	185	
4:30 PM	0	0	0	0	1	0	14	0	34	51	0	0	0	58	4	0	162	
4:45 PM	0	0	0	0	4	0	20	0	31	50	0	0	0	53	0	0	158	687
5:00 PM	0	0	0	0	1	0	24	0	33	50	0	0	0	52	3	0	163	668
5:15 PM	0	0	0	0	2	0	27	0	29	44	0	0	0	56	2	0	160	643
5:30 PM	0	0	0	0	0	0	20	0	40	59	0	0	0	46	3	0	168	649
5:45 PM	0	0	0	0	1	0	17	0	28	49	0	0	0	43	6	0	144	635
Peak 15-Min Flowrates	Northbound				Southbound				Eastbound				Westbound				Total	
	Left	Thru	Right	U	Left	Thru	Right	U	Left	Thru	Right	U	Left	Thru	Right	U		
All Vehicles	0	0	0	0	24	0	108	0	176	200	0	0	0	216	16	0	740	
Heavy Trucks	0	0	0	0	12	0	40	0	64	108	0	0	0	148	12	0	384	
Pedestrians						4				0				0			4	
Bicycles	0	0	0	0	0	0	1	0	0	0	0	0	0	0	0	0	1	
Railroad																		
Stopped Buses																		

Comments:

# Intersection #4: OR 58 & Hill Street

Type of peak hour being reported: Intersection Peak

Method for determining peak hour: Total Entering Volume

**LOCATION:** 45776 -- Conversion  
**CITY/STATE:** Oakridge, OR

**QC JOB #:** 14761204  
**DATE:** Tue, Jul 10 2018

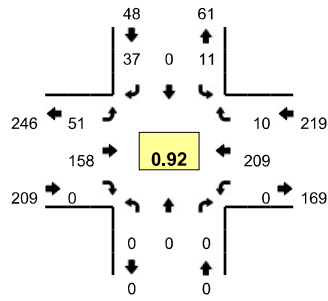

**Peak-Hour: 4:00 PM -- 5:00 PM**  
**Peak 15-Min: 4:00 PM -- 4:15 PM**

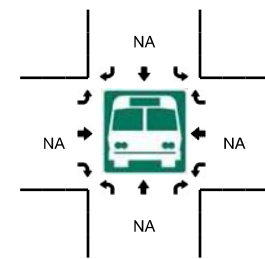
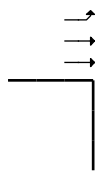
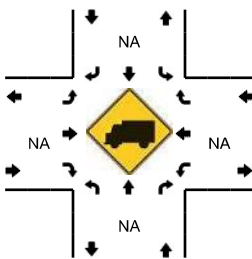
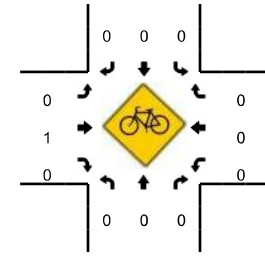
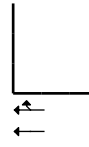
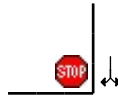
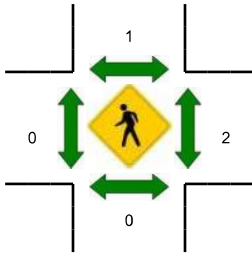
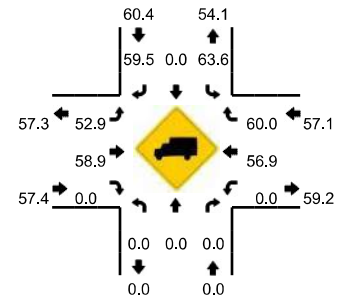

15-Min Count Period Beginning At	45776 (Northbound)				45776 (Southbound)				Conversion (Eastbound)				Conversion (Westbound)				Total	Hourly Totals
	Left	Thru	Right	U	Left	Thru	Right	U	Left	Thru	Right	U	Left	Thru	Right	U		
4:00 PM	0	0	0	0	2	0	9	0	17	34	0	0	0	67	1	0	130	
4:15 PM	0	0	0	0	1	0	11	0	10	49	0	0	0	50	3	0	124	
4:30 PM	0	0	0	0	4	0	12	0	13	42	0	0	0	44	2	0	117	
4:45 PM	0	0	0	0	4	0	5	0	11	33	0	0	0	48	4	0	105	476
5:00 PM	0	0	0	0	2	0	6	0	12	38	0	0	0	45	1	0	104	450
5:15 PM	0	0	0	0	3	0	12	0	12	33	0	0	0	43	3	0	106	432
5:30 PM	0	0	0	0	2	0	16	0	16	42	0	0	0	29	0	0	105	420
5:45 PM	0	0	0	0	0	0	8	0	16	35	0	0	0	37	6	0	102	417
Peak 15-Min Flowrates	Northbound				Southbound				Eastbound				Westbound				Total	
	Left	Thru	Right	U	Left	Thru	Right	U	Left	Thru	Right	U	Left	Thru	Right	U		
All Vehicles	0	0	0	0	8	0	36	0	68	136	0	0	0	268	4	0	520	
Heavy Trucks	0	0	0	0	4	0	16	0	40	72	0	0	0	172	4	0	308	
Pedestrians	0	0	0	0	0	0	0	0	0	0	0	0	0	4	0	0	4	
Bicycles	0	0	0	0	0	0	0	0	0	1	0	0	0	0	0	0	1	
Railroad																		
Stopped Buses																		

Comments:

# Intersection #5: Westfir-Oakridge Road/E 2nd Street

Type of peak hour being reported: Intersection Peak

Method for determining peak hour: Total Entering Volume

**LOCATION:** 45777 -- Conversion  
**CITY/STATE:** Oakridge, OR

**QC JOB #:** 14761205  
**DATE:** Tue, Jul 10 2018

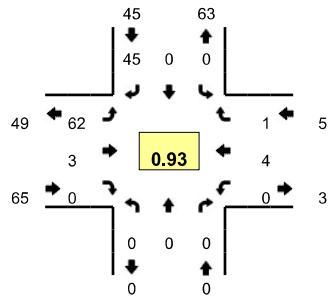

**Peak-Hour: 4:45 PM -- 5:45 PM**  
**Peak 15-Min: 4:45 PM -- 5:00 PM**

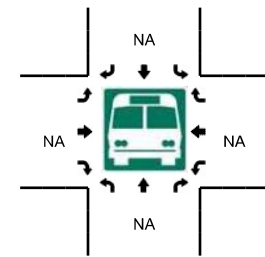
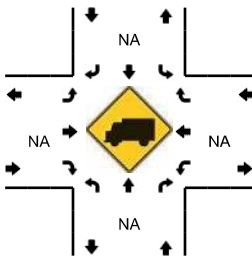
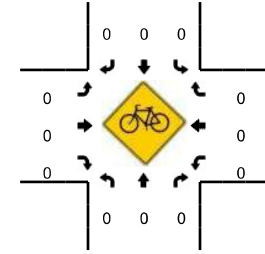
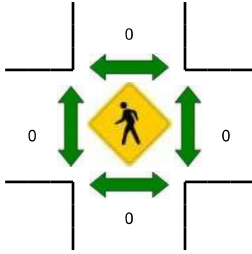
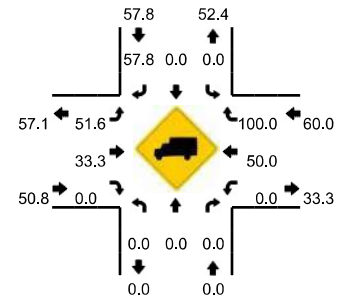

15-Min Count Period Beginning At	45777 (Northbound)				45777 (Southbound)				Conversion (Eastbound)				Conversion (Westbound)				Total	Hourly Totals
	Left	Thru	Right	U	Left	Thru	Right	U	Left	Thru	Right	U	Left	Thru	Right	U		
4:00 PM	0	0	0	0	0	0	12	0	14	1	0	0	0	0	0	0	27	
4:15 PM	0	0	0	0	1	0	9	0	24	1	0	0	0	0	0	0	35	
4:30 PM	0	0	0	0	0	0	6	0	13	0	0	0	0	0	0	0	19	
4:45 PM	0	0	0	0	0	0	11	0	17	2	0	0	0	1	0	0	31	112
5:00 PM	0	0	0	0	0	0	12	0	15	1	0	0	0	0	1	0	29	114
5:15 PM	0	0	0	0	0	0	15	0	10	0	0	0	0	1	0	0	26	105
5:30 PM	0	0	0	0	0	0	7	0	20	0	0	0	0	2	0	0	29	115
5:45 PM	0	0	0	0	0	0	13	0	14	0	0	0	0	1	0	0	28	112
Peak 15-Min Flowrates	Northbound				Southbound				Eastbound				Westbound				Total	
	Left	Thru	Right	U	Left	Thru	Right	U	Left	Thru	Right	U	Left	Thru	Right	U		
All Vehicles	0	0	0	0	0	0	44	0	68	8	0	0	0	4	0	0	124	
Heavy Trucks	0	0	0	0	0	0	28	0	28	4	0	0	0	0	0	0	60	
Pedestrians	0	0	0	0	0	0	0	0	0	0	0	0	0	0	0	0	0	
Bicycles	0	0	0	0	0	0	0	0	0	0	0	0	0	0	0	0	0	
Railroad	0	0	0	0	0	0	0	0	0	0	0	0	0	0	0	0	0	
Stopped Buses	0	0	0	0	0	0	0	0	0	0	0	0	0	0	0	0	0	

Comments:

# Intersection #6: Westfir-Oakridge Road/High Prairie Road

Type of peak hour being reported: Intersection Peak

Method for determining peak hour: Total Entering Volume

**LOCATION:** 45778 -- Conversion  
**CITY/STATE:** Oakridge, OR

**QC JOB #:** 14761206  
**DATE:** Tue, Jul 10 2018

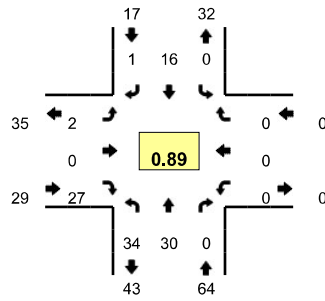

**Peak-Hour: 4:00 PM -- 5:00 PM**  
**Peak 15-Min: 4:15 PM -- 4:30 PM**

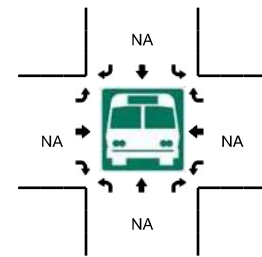
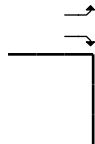
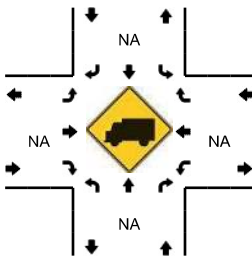
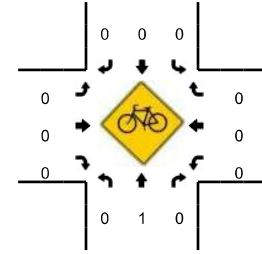
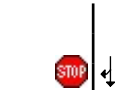
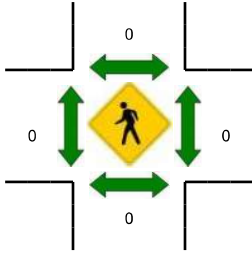
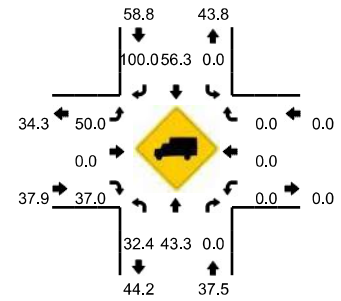

15-Min Count Period Beginning At	45778 (Northbound)				45778 (Southbound)				Conversion (Eastbound)				Conversion (Westbound)				Total	Hourly Totals
	Left	Thru	Right	U	Left	Thru	Right	U	Left	Thru	Right	U	Left	Thru	Right	U		
4:00 PM	10	6	0	0	0	1	0	0	0	0	10	0	0	0	0	0	27	
4:15 PM	4	9	0	0	0	8	1	0	0	0	9	0	0	0	0	0	31	
4:30 PM	6	8	0	0	0	5	0	0	0	0	4	0	0	0	0	0	23	
4:45 PM	14	7	0	0	0	2	0	0	2	0	4	0	0	0	0	0	29	110
5:00 PM	2	5	0	0	0	3	0	0	0	0	4	0	0	0	0	0	14	97
5:15 PM	5	4	0	0	0	2	1	0	0	0	6	0	0	0	0	0	18	84
5:30 PM	13	15	0	0	0	1	0	0	0	0	6	0	0	0	0	0	35	96
5:45 PM	6	3	0	0	0	2	1	0	0	0	8	0	0	0	0	0	20	87
Peak 15-Min Flowrates	Northbound				Southbound				Eastbound				Westbound				Total	
	Left	Thru	Right	U	Left	Thru	Right	U	Left	Thru	Right	U	Left	Thru	Right	U		
All Vehicles	16	36	0	0	0	32	4	0	0	0	36	0	0	0	0	0	124	
Heavy Trucks	8	8	0	0	0	12	4	0	0	0	12	0	0	0	0	0	44	
Pedestrians	0	0	0	0	0	0	0	0	0	0	0	0	0	0	0	0	0	
Bicycles	0	1	0	0	0	0	0	0	0	0	0	0	0	0	0	0	1	
Railroad																		
Stopped Buses																		

Comments:

---

Attachment B: Seasonal Trend Table

SEASONAL TREND TABLE (Updated: 8/1/2018)																									Seasonal Trend Peak Period Factor	Seasonal Trend K30 Value
TREND	1-Jan	15-Jan	1-Feb	15-Feb	1-Mar	15-Mar	1-Apr	15-Apr	1-May	15-May	1-Jun	15-Jun	1-Jul	15-Jul	1-Aug	15-Aug	1-Sep	15-Sep	1-Oct	15-Oct	1-Nov	15-Nov	1-Dec	15-Dec		
INTERSTATE URBANIZED	1.1818	1.1788	1.0976	1.0164	0.9998	0.9832	0.9657	0.9482	0.9460	0.9439	0.9240	0.9042	0.9115	0.9189	0.9374	0.9558	0.9558	0.9557	0.9535	0.9512	0.9625	0.9738	0.9924	1.0109	0.9042	0.0817
INTERSTATE NONURBANIZED	1.4606	1.6394	1.4676	1.2958	1.1933	1.0909	1.0645	1.0382	1.0025	0.9667	0.9201	0.8735	0.8557	0.8379	0.8295	0.8211	0.9545	1.0880	1.0500	1.0120	1.0458	1.0796	1.1313	1.1830	0.8211	0.1213
COMMUTER	1.1573	1.1317	1.0654	0.9990	0.9841	0.9691	0.9491	0.9292	0.9207	0.9123	0.9016	0.8910	0.9014	0.9119	0.9020	0.8921	0.9074	0.9228	0.9193	0.9158	0.9372	0.9586	0.9845	1.0104	0.8910	0.0974
COASTAL DESTINATION	1.2740	1.3193	1.2641	1.2090	1.1609	1.1128	1.1031	1.0934	1.0569	1.0205	0.9791	0.9377	0.8942	0.8306	0.8299	0.8293	0.8775	0.9257	0.9810	1.0363	1.1041	1.1718	1.1809	1.1900	0.8293	0.1192
COASTAL DESTINATION ROUTE	1.5060	1.6791	1.5657	1.4522	1.3599	1.2875	1.2537	1.2400	1.1531	1.0662	1.0030	0.9399	0.8492	0.7584	0.7570	0.7556	0.8301	0.9045	1.0155	1.1265	1.2128	1.2992	1.3215	1.3438	0.7556	0.1609
AGRICULTURE	1.7076	1.8032	1.6535	1.5038	1.3802	1.2567	1.1986	1.1404	1.1072	1.0740	0.9827	0.8915	0.8529	0.8142	0.7179	0.6215	0.7163	0.8110	0.8614	0.9116	1.0105	1.1093	1.2415	1.3737	0.6215	0.2229
RECREATIONAL SUMMER	1.7585	2.2489	2.0847	1.9205	1.7358	1.5512	1.4576	1.3641	1.1766	0.9892	0.9061	0.8230	0.7650	0.7071	0.7124	0.7177	0.9130	1.1082	1.4413	1.7744	1.6928	1.6112	1.6401	1.6690	0.7071	0.2037
RECREATIONAL SUMMER WINTER	1.2477	1.5073	1.5669	1.6264	1.6218	1.6172	1.7108	1.8044	1.5925	1.3807	1.2325	1.0844	0.9631	0.8419	0.8674	0.8929	0.9274	0.9619	1.3267	1.6914	1.9522	2.2130	1.6835	1.1541	0.8419	0.2052
RECREATIONAL WINTER	0.8268	1.0474	1.1721	1.2968	1.3685	1.4402	1.8693	2.2984	2.2161	2.1339	1.7818	1.4298	1.2481	1.0665	1.0903	1.1142	0.8813	0.6484	1.2488	1.8493	2.5945	3.3998	2.1613	0.9828	0.6484	0.3092
SUMMER	1.3421	1.4546	1.3422	1.2298	1.1680	1.1061	1.0661	1.0261	0.9838	0.9415	0.9095	0.8774	0.8570	0.8366	0.8182	0.7997	0.8529	0.9060	0.9353	0.9645	1.0144	1.0643	1.1024	1.1406	0.7997	0.1216
SUMMER < 2500	1.3861	1.5332	1.4106	1.2881	1.1953	1.1025	1.0553	1.0080	0.9476	0.8871	0.8570	0.8268	0.8134	0.7999	0.7782	0.7565	0.8144	0.8723	0.8868	0.9013	0.9618	1.0223	1.0984	1.1745	0.7565	0.1485

\*Seasonal Trend Table factors are based on previous year ATR data. The table is updated yearly.

\*Grey shading indicates months where seasonal factor is greater than 30%



## Appendix D – Existing Conditions Operations Worksheets

Intersection												
Int Delay, s/veh	1.6											
Movement	EBL	EBT	EBR	WBL	WBT	WBR	NBL	NBT	NBR	SBL	SBT	SBR
Lane Configurations	↵	↕		↵	↕			↕			↕	
Traffic Vol, veh/h	14	279	27	14	241	11	9	6	10	14	3	15
Future Vol, veh/h	14	279	27	14	241	11	9	6	10	14	3	15
Conflicting Peds, #/hr	0	0	0	0	0	0	0	0	2	2	0	0
Sign Control	Free	Free	Free	Free	Free	Free	Stop	Stop	Stop	Stop	Stop	Stop
RT Channelized	-	-	None	-	-	None	-	-	None	-	-	None
Storage Length	150	-	-	150	-	-	-	-	-	-	-	-
Veh in Median Storage, #	-	0	-	-	0	-	-	0	-	-	0	-
Grade, %	-	0	-	-	0	-	-	0	-	-	0	-
Peak Hour Factor	82	82	82	82	82	82	82	82	82	82	82	82
Heavy Vehicles, %	31	45	20	31	61	50	12	17	22	31	67	43
Mvmt Flow	17	340	33	17	294	13	11	7	12	17	4	18

Major/Minor	Major1			Major2			Minor1			Minor2		
Conflicting Flow All	307	0	0	373	0	0	574	732	189	545	742	154
Stage 1	-	-	-	-	-	-	391	391	-	335	335	-
Stage 2	-	-	-	-	-	-	183	341	-	210	407	-
Critical Hdwy	4.72	-	-	4.72	-	-	7.74	6.84	7.34	8.12	7.84	7.76
Critical Hdwy Stg 1	-	-	-	-	-	-	6.74	5.84	-	7.12	6.84	-
Critical Hdwy Stg 2	-	-	-	-	-	-	6.74	5.84	-	7.12	6.84	-
Follow-up Hdwy	2.51	-	-	2.51	-	-	3.62	4.17	3.52	3.81	4.67	3.73
Pot Cap-1 Maneuver	1065	-	-	999	-	-	381	319	762	364	239	749
Stage 1	-	-	-	-	-	-	578	569	-	579	503	-
Stage 2	-	-	-	-	-	-	773	601	-	696	458	-
Platoon blocked, %	-	-	-	-	-	-	-	-	-	-	-	-
Mov Cap-1 Maneuver	1065	-	-	999	-	-	358	308	761	342	231	749
Mov Cap-2 Maneuver	-	-	-	-	-	-	358	308	-	342	231	-
Stage 1	-	-	-	-	-	-	569	560	-	570	494	-
Stage 2	-	-	-	-	-	-	736	591	-	664	451	-

Approach	EB			WB			NB			SB		
HCM Control Delay, s	0.4			0.5			13.9			14.1		
HCM LOS							B			B		

Minor Lane/Major Mvmt	NBLn1	EBL	EBT	EBR	WBL	WBT	WBR	SBLn1
Capacity (veh/h)	433	1065	-	-	999	-	-	433
HCM Lane V/C Ratio	0.07	0.016	-	-	0.017	-	-	0.09
HCM Control Delay (s)	13.9	8.4	-	-	8.7	-	-	14.1
HCM Lane LOS	B	A	-	-	A	-	-	B
HCM 95th %tile Q(veh)	0.2	0	-	-	0.1	-	-	0.3

HCM 6th TWSC  
2: Rainbow Rd & OR 58

11/30/2018

Intersection						
Int Delay, s/veh	2					
Movement	EBT	EBR	WBL	WBT	NBL	NBR
Lane Configurations	↑↓		↖	↑↑	↖	↗
Traffic Vol, veh/h	296	25	46	308	26	67
Future Vol, veh/h	296	25	46	308	26	67
Conflicting Peds, #/hr	0	0	0	0	0	0
Sign Control	Free	Free	Free	Free	Stop	Stop
RT Channelized	-	None	-	None	-	None
Storage Length	-	-	200	-	100	0
Veh in Median Storage, #	0	-	-	0	0	-
Grade, %	0	-	-	0	0	-
Peak Hour Factor	85	85	85	85	85	85
Heavy Vehicles, %	41	48	42	44	29	37
Mvmt Flow	348	29	54	362	31	79

Major/Minor	Major1	Major2	Minor1			
Conflicting Flow All	0	0	377	0	652	189
Stage 1	-	-	-	-	363	-
Stage 2	-	-	-	-	289	-
Critical Hdwy	-	-	4.94	-	7.38	7.64
Critical Hdwy Stg 1	-	-	-	-	6.38	-
Critical Hdwy Stg 2	-	-	-	-	6.38	-
Follow-up Hdwy	-	-	2.62	-	3.79	3.67
Pot Cap-1 Maneuver	-	-	937	-	345	722
Stage 1	-	-	-	-	601	-
Stage 2	-	-	-	-	660	-
Platoon blocked, %	-	-	-	-	-	-
Mov Cap-1 Maneuver	-	-	937	-	325	722
Mov Cap-2 Maneuver	-	-	-	-	415	-
Stage 1	-	-	-	-	566	-
Stage 2	-	-	-	-	660	-

Approach	EB	WB	NB
HCM Control Delay, s	0	1.2	11.7
HCM LOS			B

Minor Lane/Major Mvmt	NBLn1	NBLn2	EBT	EBR	WBL	WBT
Capacity (veh/h)	415	722	-	-	937	-
HCM Lane V/C Ratio	0.074	0.109	-	-	0.058	-
HCM Control Delay (s)	14.4	10.6	-	-	9.1	-
HCM Lane LOS	B	B	-	-	A	-
HCM 95th %tile Q(veh)	0.2	0.4	-	-	0.2	-

Queues  
3: OR 58 & Crestview

11/30/2018

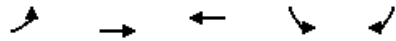

Lane Group	EBL	EBT	WBT	SBL	SBR
Lane Group Flow (vph)	163	231	291	15	97
v/c Ratio	0.33	0.16	0.31	0.08	0.39
Control Delay	5.6	3.9	12.7	17.8	10.3
Queue Delay	0.0	0.0	0.0	0.0	0.0
Total Delay	5.6	3.9	12.7	17.8	10.3
Queue Length 50th (ft)	11	8	25	3	0
Queue Length 95th (ft)	36	24	65	16	32
Internal Link Dist (ft)		595	706	893	
Turn Bay Length (ft)	200				100
Base Capacity (vph)	728	2131	1929	721	672
Starvation Cap Reductn	0	0	0	0	0
Spillback Cap Reductn	0	0	0	0	0
Storage Cap Reductn	0	0	0	0	0
Reduced v/c Ratio	0.22	0.11	0.15	0.02	0.14

Intersection Summary

# HCM 6th Signalized Intersection Summary

## 3: OR 58 & Crestview

11/30/2018

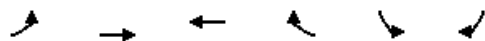

Movement	EBL	EBT	WBT	WBR	SBL	SBR
Lane Configurations	↖	↕	↗		↖	↗
Traffic Volume (veh/h)	152	215	257	14	14	90
Future Volume (veh/h)	152	215	257	14	14	90
Initial Q (Qb), veh	0	0	0	0	0	0
Ped-Bike Adj(A_pbT)	1.00			1.00	1.00	1.00
Parking Bus, Adj	1.00	1.00	1.00	1.00	1.00	1.00
Work Zone On Approach		No	No		No	
Adj Sat Flow, veh/h/ln	1013	986	945	945	1122	1095
Adj Flow Rate, veh/h	163	231	276	15	15	97
Peak Hour Factor	0.93	0.93	0.93	0.93	0.93	0.93
Percent Heavy Veh, %	54	56	59	59	46	48
Cap, veh/h	486	1102	554	30	118	103
Arrive On Green	0.14	0.59	0.32	0.32	0.11	0.11
Sat Flow, veh/h	965	1922	1778	94	1069	928
Grp Volume(v), veh/h	163	231	142	149	15	97
Grp Sat Flow(s),veh/h/ln	965	936	897	927	1069	928
Q Serve(g_s), s	3.5	1.8	4.1	4.1	0.4	3.3
Cycle Q Clear(g_c), s	3.5	1.8	4.1	4.1	0.4	3.3
Prop In Lane	1.00			0.10	1.00	1.00
Lane Grp Cap(c), veh/h	486	1102	287	297	118	103
V/C Ratio(X)	0.34	0.21	0.50	0.50	0.13	0.94
Avail Cap(c_a), veh/h	1113	2371	1136	1174	846	734
HCM Platoon Ratio	1.00	1.00	1.00	1.00	1.00	1.00
Upstream Filter(l)	1.00	1.00	1.00	1.00	1.00	1.00
Uniform Delay (d), s/veh	5.9	3.1	8.7	8.7	12.7	13.9
Incr Delay (d2), s/veh	0.4	0.1	2.0	2.0	0.5	29.4
Initial Q Delay(d3),s/veh	0.0	0.0	0.0	0.0	0.0	0.0
%ile BackOfQ(50%),veh/ln	0.4	0.1	0.6	0.7	0.1	2.4
Unsig. Movement Delay, s/veh						
LnGrp Delay(d),s/veh	6.3	3.2	10.7	10.7	13.1	43.4
LnGrp LOS	A	A	B	B	B	D
Approach Vol, veh/h		394	291		112	
Approach Delay, s/veh		4.5	10.7		39.3	
Approach LOS		A	B		D	
Timer - Assigned Phs		2		4	5	6
Phs Duration (G+Y+Rc), s		24.1		7.5	8.5	15.6
Change Period (Y+Rc), s		5.5		4.0	4.0	5.5
Max Green Setting (Gmax), s		40.0		25.0	25.0	40.0
Max Q Clear Time (g_c+I1), s		3.8		5.3	5.5	6.1
Green Ext Time (p_c), s		2.4		0.3	0.4	2.8
<b>Intersection Summary</b>						
HCM 6th Ctrl Delay			11.6			
HCM 6th LOS			B			
<b>Notes</b>						
User approved pedestrian interval to be less than phase max green.						

Intersection						
Int Delay, s/veh	2.1					
Movement	EBL	EBT	WBT	WBR	SBL	SBR
Lane Configurations	↘	↕	↕		↕	
Traffic Vol, veh/h	55	171	226	11	12	40
Future Vol, veh/h	55	171	226	11	12	40
Conflicting Peds, #/hr	0	0	0	2	0	1
Sign Control	Free	Free	Free	Free	Stop	Stop
RT Channelized	-	None	-	None	-	None
Storage Length	200	-	-	-	0	-
Veh in Median Storage, #	-	0	0	-	0	-
Grade, %	-	0	0	-	0	-
Peak Hour Factor	92	92	92	92	92	92
Heavy Vehicles, %	53	59	57	60	64	59
Mvmt Flow	60	186	246	12	13	43

Major/Minor	Major1	Major2	Minor2		
Conflicting Flow All	260	0	-	0	467 132
Stage 1	-	-	-	-	254 -
Stage 2	-	-	-	-	213 -
Critical Hdwy	5.16	-	-	-	8.08 8.08
Critical Hdwy Stg 1	-	-	-	-	7.08 -
Critical Hdwy Stg 2	-	-	-	-	7.08 -
Follow-up Hdwy	2.73	-	-	-	4.14 3.89
Pot Cap-1 Maneuver	1001	-	-	-	394 738
Stage 1	-	-	-	-	608 -
Stage 2	-	-	-	-	645 -
Platoon blocked, %		-	-	-	
Mov Cap-1 Maneuver	999	-	-	-	369 736
Mov Cap-2 Maneuver	-	-	-	-	432 -
Stage 1	-	-	-	-	570 -
Stage 2	-	-	-	-	644 -

Approach	EB	WB	SB
HCM Control Delay, s	2.1	0	11.2
HCM LOS			B

Minor Lane/Major Mvmt	EBL	EBT	WBT	WBR	SBLn1
Capacity (veh/h)	999	-	-	-	633
HCM Lane V/C Ratio	0.06	-	-	-	0.089
HCM Control Delay (s)	8.8	-	-	-	11.2
HCM Lane LOS	A	-	-	-	B
HCM 95th %tile Q(veh)	0.2	-	-	-	0.3

Intersection						
Int Delay, s/veh	8					
Movement	EBL	EBT	WBT	WBR	SBL	SBR
Lane Configurations		↔	↔		↔	
Traffic Vol, veh/h	73	4	1	0	1	41
Future Vol, veh/h	73	4	1	0	1	41
Conflicting Peds, #/hr	0	0	0	0	0	0
Sign Control	Free	Free	Free	Free	Stop	Stop
RT Channelized	-	None	-	None	-	None
Storage Length	-	-	-	-	0	-
Veh in Median Storage, #	-	0	0	-	0	-
Grade, %	-	0	0	-	0	-
Peak Hour Factor	80	80	80	80	80	80
Heavy Vehicles, %	57	25	0	0	100	68
Mvmt Flow	91	5	1	0	1	51

Major/Minor	Major1	Major2	Minor2		
Conflicting Flow All	1	0	-	0	188
Stage 1	-	-	-	-	1
Stage 2	-	-	-	-	187
Critical Hdwy	4.67	-	-	-	7.4
Critical Hdwy Stg 1	-	-	-	-	6.4
Critical Hdwy Stg 2	-	-	-	-	6.4
Follow-up Hdwy	2.713	-	-	-	4.4
Pot Cap-1 Maneuver	1326	-	-	-	622
Stage 1	-	-	-	-	817
Stage 2	-	-	-	-	656
Platoon blocked, %		-	-	-	
Mov Cap-1 Maneuver	1326	-	-	-	579
Mov Cap-2 Maneuver	-	-	-	-	579
Stage 1	-	-	-	-	761
Stage 2	-	-	-	-	656

Approach	EB	WB	SB
HCM Control Delay, s	7.5	0	9.2
HCM LOS			A

Minor Lane/Major Mvmt	EBL	EBT	WBT	WBR	SBLn1
Capacity (veh/h)	1326	-	-	-	906
HCM Lane V/C Ratio	0.069	-	-	-	0.058
HCM Control Delay (s)	7.9	0	-	-	9.2
HCM Lane LOS	A	A	-	-	A
HCM 95th %tile Q(veh)	0.2	-	-	-	0.2

HCM 6th TWSC  
6: Westfir-Oakridge Rd & High Praire Rd

11/30/2018

Intersection						
Int Delay, s/veh	1.6					
Movement	WBL	WBR	NBT	NBR	SBL	SBT
Lane Configurations	↔		↔		↔	↔
Traffic Vol, veh/h	17	1	37	32	2	29
Future Vol, veh/h	17	1	37	32	2	29
Conflicting Peds, #/hr	0	0	0	0	0	0
Sign Control	Stop	Stop	Free	Free	Free	Free
RT Channelized	-	None	-	None	-	None
Storage Length	0	-	-	-	200	-
Veh in Median Storage, #	0	-	0	-	-	0
Grade, %	0	-	0	-	-	0
Peak Hour Factor	79	79	79	79	79	79
Heavy Vehicles, %	56	100	32	43	2	29
Mvmt Flow	22	1	47	41	3	37

Major/Minor	Minor1	Major1	Major2		
Conflicting Flow All	111	68	0	0	88
Stage 1	68	-	-	-	-
Stage 2	43	-	-	-	-
Critical Hdwy	6.96	7.2	-	-	4.12
Critical Hdwy Stg 1	5.96	-	-	-	-
Critical Hdwy Stg 2	5.96	-	-	-	-
Follow-up Hdwy	4.004	4.2	-	-	2.218
Pot Cap-1 Maneuver	771	778	-	-	1508
Stage 1	834	-	-	-	-
Stage 2	858	-	-	-	-
Platoon blocked, %			-	-	-
Mov Cap-1 Maneuver	769	778	-	-	1508
Mov Cap-2 Maneuver	769	-	-	-	-
Stage 1	832	-	-	-	-
Stage 2	858	-	-	-	-

Approach	WB	NB	SB
HCM Control Delay, s	9.8	0	0.5
HCM LOS	A		

Minor Lane/Major Mvmt	NBT	NBRWBLn1	SBL	SBT
Capacity (veh/h)	-	-	769	1508
HCM Lane V/C Ratio	-	-	0.03	0.002
HCM Control Delay (s)	-	-	9.8	7.4
HCM Lane LOS	-	-	A	A
HCM 95th %tile Q(veh)	-	-	0.1	0



Intersection	
Intersection Delay, s/veh	8.8
Intersection LOS	A

Movement	EBL	EBT	EBR	WBL	WBT	WBR	NBL	NBT	NBR	SBL	SBT	SBR
Lane Configurations		↕			↕			↕			↕	
Traffic Vol, veh/h	1	26	25	126	31	14	18	14	129	8	12	5
Future Vol, veh/h	1	26	25	126	31	14	18	14	129	8	12	5
Peak Hour Factor	0.94	0.94	0.94	0.94	0.94	0.94	0.94	0.94	0.94	0.94	0.94	0.94
Heavy Vehicles, %	100	6	9	8	16	20	11	10	5	30	7	0
Mvmt Flow	1	28	27	134	33	15	19	15	137	9	13	5
Number of Lanes	0	1	0	0	1	0	0	1	0	0	1	0

Approach	EB	WB	NB	SB
Opposing Approach	WB	EB	SB	NB
Opposing Lanes	1	1	1	1
Conflicting Approach Left	SB	NB	EB	WB
Conflicting Lanes Left	1	1	1	1
Conflicting Approach Right	NB	SB	WB	EB
Conflicting Lanes Right	1	1	1	1
HCM Control Delay	9.6	9.1	8.4	8.4
HCM LOS	A	A	A	A

Lane	NBLn1	EBLn1	WBLn1	SBLn1
Vol Left, %	11%	2%	74%	32%
Vol Thru, %	9%	50%	18%	48%
Vol Right, %	80%	48%	8%	20%
Sign Control	Stop	Stop	Stop	Stop
Traffic Vol by Lane	161	52	171	25
LT Vol	18	1	126	8
Through Vol	14	26	31	12
RT Vol	129	25	14	5
Lane Flow Rate	171	55	182	27
Geometry Grp	1	1	1	1
Degree of Util (X)	0.203	0.092	0.236	0.038
Departure Headway (Hd)	4.272	5.983	4.663	5.158
Convergence, Y/N	Yes	Yes	Yes	Yes
Cap	841	599	771	694
Service Time	2.293	4.015	2.689	3.188
HCM Lane V/C Ratio	0.203	0.092	0.236	0.039
HCM Control Delay	8.4	9.6	9.1	8.4
HCM Lane LOS	A	A	A	A
HCM 95th-tile Q	0.8	0.3	0.9	0.1

## Appendix E – Future Conditions Operations Worksheets

Intersection												
Int Delay, s/veh	1.5											
Movement	EBL	EBT	EBR	WBL	WBT	WBR	NBL	NBT	NBR	SBL	SBT	SBR
Lane Configurations	↵	↕		↵	↕			↕			↕	
Traffic Vol, veh/h	16	367	30	16	317	12	10	7	11	16	3	17
Future Vol, veh/h	16	367	30	16	317	12	10	7	11	16	3	17
Conflicting Peds, #/hr	0	0	0	0	0	0	0	0	2	2	0	0
Sign Control	Free	Free	Free	Free	Free	Free	Stop	Stop	Stop	Stop	Stop	Stop
RT Channelized	-	-	None	-	-	None	-	-	None	-	-	None
Storage Length	150	-	-	150	-	-	-	-	-	-	-	-
Veh in Median Storage, #	-	0	-	-	0	-	-	0	-	-	0	-
Grade, %	-	0	-	-	0	-	-	0	-	-	0	-
Peak Hour Factor	95	95	95	95	95	95	95	95	95	95	95	95
Heavy Vehicles, %	31	45	20	31	61	50	12	17	22	31	67	43
Mvmt Flow	17	386	32	17	334	13	11	7	12	17	3	18

Major/Minor	Major1			Major2			Minor1			Minor2		
Conflicting Flow All	347	0	0	418	0	0	639	817	211	608	827	174
Stage 1	-	-	-	-	-	-	436	436	-	375	375	-
Stage 2	-	-	-	-	-	-	203	381	-	233	452	-
Critical Hdwy	4.72	-	-	4.72	-	-	7.74	6.84	7.34	8.12	7.84	7.76
Critical Hdwy Stg 1	-	-	-	-	-	-	6.74	5.84	-	7.12	6.84	-
Critical Hdwy Stg 2	-	-	-	-	-	-	6.74	5.84	-	7.12	6.84	-
Follow-up Hdwy	2.51	-	-	2.51	-	-	3.62	4.17	3.52	3.81	4.67	3.73
Pot Cap-1 Maneuver	1025	-	-	956	-	-	341	283	736	325	208	725
Stage 1	-	-	-	-	-	-	543	542	-	545	477	-
Stage 2	-	-	-	-	-	-	752	576	-	672	432	-
Platoon blocked, %	-	-	-	-	-	-	-	-	-	-	-	-
Mov Cap-1 Maneuver	1025	-	-	956	-	-	320	273	735	305	201	725
Mov Cap-2 Maneuver	-	-	-	-	-	-	320	273	-	305	201	-
Stage 1	-	-	-	-	-	-	534	533	-	536	468	-
Stage 2	-	-	-	-	-	-	716	566	-	640	425	-

Approach	EB			WB			NB			SB		
HCM Control Delay, s	0.3			0.4			15			15.1		
HCM LOS							C			C		

Minor Lane/Major Mvmt	NBLn1	EBL	EBT	EBR	WBL	WBT	WBR	SBLn1
Capacity (veh/h)	390	1025	-	-	956	-	-	396
HCM Lane V/C Ratio	0.076	0.016	-	-	0.018	-	-	0.096
HCM Control Delay (s)	15	8.6	-	-	8.8	-	-	15.1
HCM Lane LOS	C	A	-	-	A	-	-	C
HCM 95th %tile Q(veh)	0.2	0.1	-	-	0.1	-	-	0.3

Intersection						
Int Delay, s/veh	1.5					
Movement	EBT	EBR	WBL	WBT	NBL	NBR
Lane Configurations	↑↑		↘	↑↑	↘	↗
Traffic Vol, veh/h	389	28	17	405	29	75
Future Vol, veh/h	389	28	17	405	29	75
Conflicting Peds, #/hr	0	0	0	0	0	0
Sign Control	Free	Free	Free	Free	Stop	Stop
RT Channelized	-	None	-	None	-	None
Storage Length	-	-	200	-	100	0
Veh in Median Storage, #	0	-	-	0	0	-
Grade, %	0	-	-	0	0	-
Peak Hour Factor	95	95	95	95	95	95
Heavy Vehicles, %	41	48	42	44	29	37
Mvmt Flow	409	29	18	426	31	79

Major/Minor	Major1	Major2	Minor1		
Conflicting Flow All	0	0	438	0	673
Stage 1	-	-	-	-	424
Stage 2	-	-	-	-	249
Critical Hdwy	-	-	4.94	-	7.38
Critical Hdwy Stg 1	-	-	-	-	6.38
Critical Hdwy Stg 2	-	-	-	-	6.38
Follow-up Hdwy	-	-	2.62	-	3.79
Pot Cap-1 Maneuver	-	-	880	-	334
Stage 1	-	-	-	-	555
Stage 2	-	-	-	-	695
Platoon blocked, %	-	-	-	-	-
Mov Cap-1 Maneuver	-	-	880	-	327
Mov Cap-2 Maneuver	-	-	-	-	421
Stage 1	-	-	-	-	544
Stage 2	-	-	-	-	695

Approach	EB	WB	NB
HCM Control Delay, s	0	0.4	11.8
HCM LOS			B

Minor Lane/Major Mvmt	NBLn1	NBLn2	EBT	EBR	WBL	WBT
Capacity (veh/h)	421	688	-	-	880	-
HCM Lane V/C Ratio	0.073	0.115	-	-	0.02	-
HCM Control Delay (s)	14.2	10.9	-	-	9.2	-
HCM Lane LOS	B	B	-	-	A	-
HCM 95th %tile Q(veh)	0.2	0.4	-	-	0.1	-

Queues  
3: OR 58 & Crestview

11/30/2018

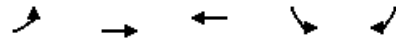

Lane Group	EBL	EBT	WBT	SBL	SBR
Lane Group Flow (vph)	179	298	373	17	105
v/c Ratio	0.37	0.20	0.38	0.09	0.41
Control Delay	5.9	3.9	13.2	19.7	10.9
Queue Delay	0.0	0.0	0.0	0.0	0.0
Total Delay	5.9	3.9	13.2	19.7	10.9
Queue Length 50th (ft)	12	12	36	4	0
Queue Length 95th (ft)	41	32	86	20	35
Internal Link Dist (ft)		595	706	893	
Turn Bay Length (ft)	200				100
Base Capacity (vph)	719	2131	1851	697	655
Starvation Cap Reductn	0	0	0	0	0
Spillback Cap Reductn	0	0	0	0	0
Storage Cap Reductn	0	0	0	0	0
Reduced v/c Ratio	0.25	0.14	0.20	0.02	0.16

Intersection Summary

# HCM 6th Signalized Intersection Summary

## 3: OR 58 & Crestview

11/30/2018



Movement	EBL	EBT	WBT	WBR	SBL	SBR
Lane Configurations	↶	↶↶	↶↶		↶	↶
Traffic Volume (veh/h)	170	283	338	16	16	100
Future Volume (veh/h)	170	283	338	16	16	100
Initial Q (Qb), veh	0	0	0	0	0	0
Ped-Bike Adj(A_pbT)	1.00			1.00	1.00	1.00
Parking Bus, Adj	1.00	1.00	1.00	1.00	1.00	1.00
Work Zone On Approach		No	No		No	
Adj Sat Flow, veh/h/ln	1013	986	945	945	1122	1095
Adj Flow Rate, veh/h	179	298	356	17	17	105
Peak Hour Factor	0.95	0.95	0.95	0.95	0.95	0.95
Percent Heavy Veh, %	54	56	59	59	46	48
Cap, veh/h	452	1132	586	28	133	115
Arrive On Green	0.15	0.60	0.34	0.34	0.12	0.12
Sat Flow, veh/h	965	1922	1791	83	1069	928
Grp Volume(v), veh/h	179	298	183	190	17	105
Grp Sat Flow(s),veh/h/ln	965	936	897	929	1069	928
Q Serve(g_s), s	4.1	2.6	5.9	6.0	0.5	3.9
Cycle Q Clear(g_c), s	4.1	2.6	5.9	6.0	0.5	3.9
Prop In Lane	1.00			0.09	1.00	1.00
Lane Grp Cap(c), veh/h	452	1132	302	312	133	115
V/C Ratio(X)	0.40	0.26	0.61	0.61	0.13	0.91
Avail Cap(c_a), veh/h	992	2139	1025	1062	763	662
HCM Platoon Ratio	1.00	1.00	1.00	1.00	1.00	1.00
Upstream Filter(l)	1.00	1.00	1.00	1.00	1.00	1.00
Uniform Delay (d), s/veh	6.3	3.3	9.7	9.7	13.7	15.1
Incr Delay (d2), s/veh	0.6	0.2	3.0	2.9	0.4	22.3
Initial Q Delay(d3),s/veh	0.0	0.0	0.0	0.0	0.0	0.0
%ile BackOfQ(50%),veh/ln	0.5	0.2	1.0	1.1	0.1	0.7
Unsig. Movement Delay, s/veh						
LnGrp Delay(d),s/veh	6.9	3.4	12.7	12.6	14.1	37.5
LnGrp LOS	A	A	B	B	B	D
Approach Vol, veh/h		477	373		122	
Approach Delay, s/veh		4.7	12.7		34.2	
Approach LOS		A	B		C	
Timer - Assigned Phs		2		4	5	6
Phs Duration (G+Y+Rc), s		26.7		8.3	9.4	17.3
Change Period (Y+Rc), s		5.5		4.0	4.0	5.5
Max Green Setting (Gmax), s		40.0		25.0	25.0	40.0
Max Q Clear Time (g_c+I1), s		4.6		5.9	6.1	8.0
Green Ext Time (p_c), s		3.2		0.3	0.5	3.7
<b>Intersection Summary</b>						
HCM 6th Ctrl Delay			11.5			
HCM 6th LOS			B			
<b>Notes</b>						
User approved pedestrian interval to be less than phase max green.						

Intersection						
Int Delay, s/veh	1.9					
Movement	EBL	EBT	WBT	WBR	SBL	SBR
Lane Configurations	↘	↕↕	↕↔		↘	
Traffic Vol, veh/h	61	225	297	12	13	45
Future Vol, veh/h	61	225	297	12	13	45
Conflicting Peds, #/hr	1	0	0	1	2	0
Sign Control	Free	Free	Free	Free	Stop	Stop
RT Channelized	-	None	-	None	-	None
Storage Length	200	-	-	-	0	-
Veh in Median Storage, #	-	0	0	-	0	-
Grade, %	-	0	0	-	0	-
Peak Hour Factor	95	95	95	95	95	95
Heavy Vehicles, %	53	59	57	60	64	59
Mvmt Flow	64	237	313	13	14	47

Major/Minor	Major1	Major2	Minor2		
Conflicting Flow All	327	0	-	0	570 164
Stage 1	-	-	-	-	321 -
Stage 2	-	-	-	-	249 -
Critical Hdwy	5.16	-	-	-	8.08 8.08
Critical Hdwy Stg 1	-	-	-	-	7.08 -
Critical Hdwy Stg 2	-	-	-	-	7.08 -
Follow-up Hdwy	2.73	-	-	-	4.14 3.89
Pot Cap-1 Maneuver	932	-	-	-	330 699
Stage 1	-	-	-	-	553 -
Stage 2	-	-	-	-	613 -
Platoon blocked, %		-	-	-	
Mov Cap-1 Maneuver	931	-	-	-	307 698
Mov Cap-2 Maneuver	-	-	-	-	382 -
Stage 1	-	-	-	-	514 -
Stage 2	-	-	-	-	612 -

Approach	EB	WB	SB
HCM Control Delay, s	2	0	11.8
HCM LOS			B

Minor Lane/Major Mvmt	EBL	EBT	WBT	WBR	SBLn1
Capacity (veh/h)	931	-	-	-	589
HCM Lane V/C Ratio	0.069	-	-	-	0.104
HCM Control Delay (s)	9.2	-	-	-	11.8
HCM Lane LOS	A	-	-	-	B
HCM 95th %tile Q(veh)	0.2	-	-	-	0.3

Intersection						
Int Delay, s/veh	8					
Movement	EBL	EBT	WBT	WBR	SBL	SBR
Lane Configurations		↔	↔		↔	
Traffic Vol, veh/h	81	4	1	0	1	46
Future Vol, veh/h	81	4	1	0	1	46
Conflicting Peds, #/hr	0	0	0	0	0	0
Sign Control	Free	Free	Free	Free	Stop	Stop
RT Channelized	-	None	-	None	-	None
Storage Length	-	-	-	-	0	-
Veh in Median Storage, #	-	0	0	-	0	-
Grade, %	-	0	0	-	0	-
Peak Hour Factor	90	90	90	90	90	90
Heavy Vehicles, %	57	25	0	0	100	68
Mvmt Flow	90	4	1	0	1	51

Major/Minor	Major1	Major2	Minor2		
Conflicting Flow All	1	0	-	0	185
Stage 1	-	-	-	-	1
Stage 2	-	-	-	-	184
Critical Hdwy	4.67	-	-	-	7.4
Critical Hdwy Stg 1	-	-	-	-	6.4
Critical Hdwy Stg 2	-	-	-	-	6.4
Follow-up Hdwy	2.713	-	-	-	4.4
Pot Cap-1 Maneuver	1326	-	-	-	625
Stage 1	-	-	-	-	817
Stage 2	-	-	-	-	659
Platoon blocked, %		-	-	-	
Mov Cap-1 Maneuver	1326	-	-	-	583
Mov Cap-2 Maneuver	-	-	-	-	583
Stage 1	-	-	-	-	761
Stage 2	-	-	-	-	659

Approach	EB	WB	SB
HCM Control Delay, s	7.5	0	9.2
HCM LOS			A

Minor Lane/Major Mvmt	EBL	EBT	WBT	WBR	SBLn1
Capacity (veh/h)	1326	-	-	-	908
HCM Lane V/C Ratio	0.068	-	-	-	0.058
HCM Control Delay (s)	7.9	0	-	-	9.2
HCM Lane LOS	A	A	-	-	A
HCM 95th %tile Q(veh)	0.2	-	-	-	0.2



HCM 6th TWSC  
6: Westir- Oakridge & High Praire Rd

11/30/2018

Intersection						
Int Delay, s/veh	1.5					
Movement	WBL	WBR	NBT	NBR	SBL	SBT
Lane Configurations	↔		↔		↔	↔
Traffic Vol, veh/h	19	1	41	36	2	32
Future Vol, veh/h	19	1	41	36	2	32
Conflicting Peds, #/hr	0	0	0	0	0	0
Sign Control	Stop	Stop	Free	Free	Free	Free
RT Channelized	-	None	-	None	-	None
Storage Length	0	-	-	-	200	-
Veh in Median Storage, #	0	-	0	-	-	0
Grade, %	0	-	0	-	-	0
Peak Hour Factor	90	90	90	90	90	90
Heavy Vehicles, %	0	0	43	0	0	56
Mvmt Flow	21	1	46	40	2	36

Major/Minor	Minor1	Major1	Major2		
Conflicting Flow All	106	66	0	0	86
Stage 1	66	-	-	-	-
Stage 2	40	-	-	-	-
Critical Hdwy	6.4	6.2	-	-	4.1
Critical Hdwy Stg 1	5.4	-	-	-	-
Critical Hdwy Stg 2	5.4	-	-	-	-
Follow-up Hdwy	3.5	3.3	-	-	2.2
Pot Cap-1 Maneuver	897	1003	-	-	1523
Stage 1	962	-	-	-	-
Stage 2	988	-	-	-	-
Platoon blocked, %			-	-	-
Mov Cap-1 Maneuver	896	1003	-	-	1523
Mov Cap-2 Maneuver	896	-	-	-	-
Stage 1	961	-	-	-	-
Stage 2	988	-	-	-	-

Approach	WB	NB	SB
HCM Control Delay, s	9.1	0	0.4
HCM LOS	A		

Minor Lane/Major Mvmt	NBT	NBRWBLn1	SBL	SBT
Capacity (veh/h)	-	-	901	1523
HCM Lane V/C Ratio	-	-	0.025	0.001
HCM Control Delay (s)	-	-	9.1	7.4
HCM Lane LOS	-	-	A	A
HCM 95th %tile Q(veh)	-	-	0.1	0

Intersection	
Intersection Delay, s/veh	9.2
Intersection LOS	A

Movement	EBL	EBT	EBR	WBL	WBT	WBR	NBL	NBT	NBR	SBL	SBT	SBR
Lane Configurations		↕			↕			↕			↕	
Traffic Vol, veh/h	1	29	28	141	35	16	20	16	144	9	13	6
Future Vol, veh/h	1	29	28	141	35	16	20	16	144	9	13	6
Peak Hour Factor	0.94	0.94	0.94	0.94	0.94	0.94	0.94	0.94	0.94	0.94	0.94	0.94
Heavy Vehicles, %	100	6	9	8	16	20	11	10	5	30	7	0
Mvmt Flow	1	31	30	150	37	17	21	17	153	10	14	6
Number of Lanes	0	1	0	0	1	0	0	1	0	0	1	0

Approach	EB	WB	NB	SB
Opposing Approach	WB	EB	SB	NB
Opposing Lanes	1	1	1	1
Conflicting Approach Left	SB	NB	EB	WB
Conflicting Lanes Left	1	1	1	1
Conflicting Approach Right	NB	SB	WB	EB
Conflicting Lanes Right	1	1	1	1
HCM Control Delay	9.8	9.5	8.7	8.5
HCM LOS	A	A	A	A

Lane	NBLn1	EBLn1	WBLn1	SBLn1
Vol Left, %	11%	2%	73%	32%
Vol Thru, %	9%	50%	18%	46%
Vol Right, %	80%	48%	8%	21%
Sign Control	Stop	Stop	Stop	Stop
Traffic Vol by Lane	180	58	192	28
LT Vol	20	1	141	9
Through Vol	16	29	35	13
RT Vol	144	28	16	6
Lane Flow Rate	191	62	204	30
Geometry Grp	1	1	1	1
Degree of Util (X)	0.232	0.104	0.269	0.044
Departure Headway (Hd)	4.357	6.075	4.734	5.259
Convergence, Y/N	Yes	Yes	Yes	Yes
Cap	823	589	758	680
Service Time	2.384	4.117	2.768	3.299
HCM Lane V/C Ratio	0.232	0.105	0.269	0.044
HCM Control Delay	8.7	9.8	9.5	8.5
HCM Lane LOS	A	A	A	A
HCM 95th-tile Q	0.9	0.3	1.1	0.1

## Appendix F – Critical Crash Rate Calculations

Location	Collision Type						Severity		Total Crashes	Critical Crash Rate by Intersection Type	Critical Crash Rate by Volume	Observed Crash Rate
	Rear-end	Turning	Angle	Fixed	Ped	Side-Swipe	PDO <sup>1</sup>	Injury				
River Road/OR 58	1	0	0	0	0	0	1	0	1	0.45	0.36	0.09
Rainbow Road/OR 58	0	1	0	0	1	0	1	1	2	0.33	0.44	0.14
Crestview Street/OR 58	0	2	0	1	0	0	2	1	3	0.55	0.35	0.22
Hill Street/OR 58	0	0	0	0	0	0	0	0	0	0.38	0.40	0.00
Westfir-Oakridge Road/E 2nd Street	0	1	0	0	0	0	1	0	1	0.76	0.79	0.46
Westfir-Oakridge Road/High Prairie Road	0	0	0	0	0	0	0	0	0	0.77	0.79	0.00
Crestview Street/E 1st Street	0	0	0	1	0	0	1	0	1	0.53	0.43	0.13

Location	PM Peak				Intersection Class	Ra	K	M	Rc	AADT Class	Ra	K	M	Rc
	AVG	EST AADT	EST 5Y TEV	Crash Rate										
River Road/OR 58	643	6,430	11,734,750	0.09	4 ST	0.198	1.645	12	0.45	x<7500	0.141	1.645	12	0.36
Rainbow Road/OR 58	768	7,680	14,016,000	0.14	3 ST	0.131	1.645	14	0.33	7500<x<15000	0.204	1.645	14	0.44
Crestview Street/OR 58	742	7,420	13,541,500	0.22	3 SG	0.275	1.645	14	0.55	x<7500	0.141	1.645	14	0.35
Hill Street/OR 58	515	5,150	9,398,750	0.00	3 ST	0.131	1.645	9	0.38	x<7500	0.141	1.645	9	0.40
Westfir-Oakridge Road/E 2nd Street	120	1,200	2,190,000	0.46	3 ST	0.131	1.645	2	0.76	x<7500	0.141	1.645	2	0.79
Westfir-Oakridge Road/High Prairie Road	118	1,180	2,153,500	0.00	3 ST	0.131	1.645	2	0.77	x<7500	0.141	1.645	2	0.79
Crestview Street/E 1st Street	409	4,090	7,464,250	0.13	4 ST	0.198	1.645	7	0.53	x<7500	0.141	1.645	7	0.43

Appendix G – Pedestrian Qualitative Analysis Results

**Table G1. Pedestrian Qualitative Analysis**

Roadway	Roadway Extents	Qualitative Score
W 2nd Street	OR 58 to Commercial St	Poor
W 2nd Street	Commercial St to Portal Dr	Poor
W 2nd Street	Portal Dr to Elder St	Fair
Union Street	W 2nd St to OR 58	Poor
Commercial St	W 2nd St to Crestview St	Good
Commercial St	Crestview St to Beech St	Poor
W 1st Street	Poplar St to Crestview St	Good
E 1st Street	Crestview St to Beech St	Excellent
E 1st Street	Beech St to Fish Hatchery Rd	Good
Portal Dr	W 2nd St to Commercial St	Poor
Poplar St	W 2nd St to Commercial St	Poor
Crestview St	W 2nd St to Commercial St	Excellent
Crestview St	Commercial St to OR 58	Poor
Oak St	E 1st St to E 2nd St	Poor
E 2nd Street	Oak St to Westoak Rd	Poor
Westoak Road	E 2nd St to High Prairie Rd	Poor
Westoak Road	High Prairie Rd to Norquist Ln	Poor
Beech Street	E 1st St to Hill St	Good
Hill Street	Beech St to OR 58	Good
Fish Hatcher Road	E 1st St to OR 58	Poor
Industrial Park Way	Fish Hatchery Rd to OR 58	Poor
River Road	OR 58 to School St	Fair
School Street	River Rd to Rainbow St	Excellent
Garden Road	School St to Fairyglen Dr	Good
Rainbow Street	OR 58 to Fairyglen Dr	Excellent
Rock Road	OR 58 to Berry St	Poor
OR 58	River Rd to Rainbow St	Fair
OR 58	Rainbow St to Crestview St	Poor
OR 58	Crestview St to Hill St	Poor
OR 58	Hill St to Fish Hatchery Rd	Poor

**Oakridge Existing Pedestrian Qualitative Analysis**

Location	Bound	Direction	Sidewalk Presence	Sidewalk Condition	Sidewalk Width	Lighting	Grade	Buffer	Travel Lane Speed	Combined
W 2nd Street	OR 58 to Commercial St	NB	1	2	1	0	1	0	3	Poor
		SB	2	2	3	0	1	0	3	
W 2nd Street	Commercial St to Portal Dr	EB	0	0	0	0	2	0	3	Poor
		WB	0	0	0	0	2	0	3	
W 2nd Street	Portal Dr to Elder St	EB	3	3	3	1	2	2	3	Fair
		WB	0	0	0	0	2	0	3	
Union Street	W 2nd St to OR 58	EB	0	0	0	0	3	0	3	Poor
		WB	0	0	0	0	3	0	3	
Commercial St	W 2nd St to Crestview St	EB	1	3	1	1	3	0	3	Good
		WB	3	3	2	1	3	0	3	
Commercial St	Crestview St to Beech St	EB	0	0	0	0	3	0	3	Poor
		WB	3	2	1	1	3	0	3	
W 1st Street	Poplar St to Crestview St	EB	1	2	3	1	3	0	3	Good
		WB	2	2	3	1	3	0	3	
E 1st Street	Crestview St to Beech St	EB	3	2	3	1	3	0	3	Excellent
		WB	3	2	3	1	3	0	3	
E 1st Street	Beech St to Fish Hatchery Rd	EB	1	2	3	0	3	1	3	Good
		WB	2	2	3	0	3	1	3	
Portal Dr	W 2nd St to Commercial St	NB	0	0	0	0	2	0	3	Poor
		SB	0	0	0	0	2	0	3	
Poplar St	W 2nd St to Commercial St	NB	2	1	1	0	2	1	3	Poor
		SB	1	0	0	0	2	0	3	
Crestview St	W 2nd St to Commercial St	NB	3	3	3	1	2	1	3	Excellent
		SB	2	3	3	1	2	1	3	
Crestview St	Commercial St to OR 58	NB	3	3	3	0	1	0	3	Poor
		SB	0	0	0	0	1	0	3	
Oak St	E 1st St to E 2nd St	NB	1	1	1	0	0	0	3	Poor
		SB	2	3	3	0	0	0	3	
E 2nd Street	Oak St to Westoak Rd	EB	1	2	1	0	2	0	3	Poor
		WB	0	0	0	0	2	0	3	
Westoak Road	E 2nd St to High Prairie Rd	EB	0	0	0	0	1	0	3	Poor
		WB	0	0	0	0	1	0	3	
Westoak Road	High Prairie Rd to Norquist Ln	NB	0	0	0	0	1	0	3	Poor
		SB	0	0	0	0	1	0	3	
Beech Street	E 1st St to Hill St	NB	2	3	2	1	2	1	3	Good
		SB	2	3	2	1	2	1	3	
Hill Street	Beech St to OR 58	NB	2	2	2	2	3	0	3	Good
		SB	2	2	2	2	3	0	3	
Fish Hatcher Road	E 1st St to OR 58	NB	0	0	0	0	2	0	3	Poor
		SB	0	0	0	0	2	0	3	
Industrial Park Way	Fish Hatchery Rd to OR 58	EB	0	0	0	0	2	0	3	Poor
		WB	0	0	0	0	2	0	3	
River Road	OR 58 to School St	NB	3	3	3	0	3	1	3	Fair
		SB	0	0	0	0	3	1	3	
School Street	River Rd to Rainbow St	EB	3	3	3	0	3	1	3	Excellent
		WB	3	3	3	0	3	1	3	
Garden Road	School St to Fairyglen Dr	NB	1	3	3	1	3	1	3	Good
		SB	1	3	3	1	3	1	3	
Rainbow Street	OR 58 to Fairyglen Dr	NB	1	3	3	0	3	3	3	Excellent
		SB	2	3	3	0	3	1	3	
Rock Road	OR 58 to Berry St	NB	0	0	0	0	3	0	3	Poor
		SB	0	0	0	0	3	0	3	
OR 58	River Rd to Rainbow St	EB	1	2	2	3	0	0	1	Fair
		WB	3	2	2	3	0	0	1	
OR 58	Rainbow St to Crestview St	EB	0	0	0	2	0	0	1	Poor
		WB	0	0	0	2	0	0	1	
OR 58	Crestview St to Hill St	EB	0	0	0	1	0	0	1	Poor
		WB	0	0	0	1	0	0	1	
OR 58	Hill St to Fish Hatchery Rd	EB	0	0	0	1	0	0	1	Poor
		WB	0	0	0	1	0	0	1	



## Appendix H –Bicycle Qualitative Analysis Results

**Table H1. Bicycle Qualitative Analysis**

Roadway	Roadway Extents	Qualitative Score
W 2nd Street	OR 58 to Portal Dr	Poor
W 2nd Street	Portal Dr to Elder St	Good
Union Street	W 2nd St to OR 58	Fair
Commercial St	W 2nd St to Beech St	Poor
1st Street	Poplar St to Fish Hatchery Rd	Poor
Portal Dr	W 2nd St to Commercial St	Poor
Poplar St	W 2nd St to Commercial St	Poor
Crestview St	W 2nd St to W 1st St	Good
Crestview St	W 1st St to OR 58	Poor
Oak St	E 1st St to E 2nd St	Poor
E 2nd Street	Oak St to Westoak Rd	Poor
Westoak Road	E 2nd St to High Prairie Rd	Poor
Westoak Road	High Prairie Rd to Norquist Ln	Poor
Beech Street	E 1st St to Hill St	Poor
Hill Street	Beech St to OR 58	Poor
Fish Hatcher Road	E 1st St to OR 58	Fair
Industrial Park Way	Fish Hatchery Rd to OR 58	Poor
River Road	OR 58 to School St	Poor
School Street	River Rd to Rainbow St	Poor
Garden Road	School St to Fairyglen Dr	Good
Rainbow Street	OR 58 to School St	Excellent
Rainbow Street	School St to Fairyglen Dr	Poor
Rock Road	OR 58 to Berry St	Fair
OR 58	Rainbow St to Fish Hatchery Rd	Poor

**Oakridge Existing Bicycle Qualitative Analysis**

Location	Bound	Direction	Bicycle Lane Presence	Shoulder Presence	Grade	Pavement	On-street parking	Travel Lane Speed	Combined
W 2nd Street	OR 58 to Portal Dr	EB	0	0	1	2	1	3	Poor
		WB	0	0	1	2	1	3	
W 2nd Street	Portal Dr to Elder St	EB	0	1	2	3	1	3	Good
		WB	3	3	2	3	1	3	
Union Street	W 2nd St to OR 58	EB	0	0	3	3	3	3	Fair
		WB	0	0	3	3	3	3	
Commercial St	W 2nd St to Beech St	EB	0	1	3	2	1	3	Poor
		WB	0	1	3	2	1	3	
1st Street	Poplar St to Fish Hatchery Rd	EB	0	1	3	2	1	3	Poor
		WB	0	1	3	2	1	3	
Portal Dr	W 2nd St to Commercial St	NB	0	0	2	1	1	3	Poor
		SB	0	0	2	1	1	3	
Poplar St	W 2nd St to Commercial St	NB	0	0	2	1	1	3	Poor
		SB	0	0	2	1	1	3	
Crestview St	W 2nd St to W 1st St	NB	3	0	1	3	1	3	Good
		SB	3	0	1	3	1	3	
Crestview St	W 1st St to OR 58	NB	0	0	0	2	3	3	Poor
		SB	0	0	0	2	3	3	
Oak St	E 1st St to E 2nd St	NB	0	1	0	3	3	3	Poor
		SB	0	1	0	3	3	3	
E 2nd Street	Oak St to Westoak Rd	EB	0	0	0	2	3	3	Poor
		WB	0	0	0	2	3	3	
Westoak Road	E 2nd St to High Prairie Rd	EB	0	1	0	2	3	3	Poor
		WB	0	1	1	2	3	3	
Westoak Road	High Prairie Rd to Norquist Ln	NB	0	0	1	2	3	3	Poor
		SB	0	0	1	2	3	3	
Beech Street	E 1st St to Hill St	NB	0	0	2	2	3	3	Poor
		SB	0	0	2	2	3	3	
Hill Street	Beech St to OR 58	NB	0	0	3	2	3	3	Poor
		SB	0	0	3	2	3	3	
Fish Hatcher Road	E 1st St to OR 58	NB	0	1	2	3	3	3	Fair
		SB	0	1	2	3	3	3	
Industrial Park Way	Fish Hatchery Rd to OR 58	EB	0	0	2	1	3	3	Poor
		WB	0	0	2	1	3	3	
River Road	OR 58 to School St	NB	0	0	3	2	3	3	Poor
		SB	0	0	3	2	3	3	
School Street	River Rd to Rainbow St	EB	0	0	3	2	3	3	Poor
		WB	0	0	3	2	3	3	
Garden Road	School St to Fairyglen Dr	NB	2	0	3	2	3	3	Good
		SB	2	0	3	2	3	3	
Rainbow Street	OR 58 to School St	NB	3	0	3	3	3	3	Excellent
		SB	3	0	3	3	3	3	
Rainbow Street	School St to Fairyglen Dr	NB	0	0	3	2	3	3	Poor
		SB	0	0	3	2	3	3	
Rock Road	OR 58 to Berry St	NB	0	0	3	3	3	3	Fair
		SB	0	0	3	3	3	3	
OR 58	Rainbow St to Fish Hatchery Rd	EB	0	1	2	3	3	1	Poor
		WB	0	1	2	3	3	1	

## Appendix I – Bridge Inventory

FACS Data-To-Go Asset Query: 11/27/2018 4:49:39 PM

1

Highway Name: WILLAMETTE

Highway Number: 018

Highway Suffix: 00

Roadway ID: 1

Start Milepoint: 34

End Milepoint: 37

Buffer Distance: 1.0

Filter: All Assets

Records Returned: 6

ASSET: BRIDGES

-Column headers marked as "1R" are required

-Please update the Verified No Change column from No to Yes after field verifying that the data is correct

HIGHWAY 1R	MILEPOINT 1R	BRIDGE	BRIDGE NAME	YEAR	LENGTH (FT)	HORIZONTAL CLEARANCE (FT)	DECK RATING	ROADWAY DECK WIDTH (FT) 1R	SUFFICIENCY RATING	DESIGN LOAD	CONDITION PER INSPECTION	SUBSTRATING	STRUCTURE TYPE	SUPRATING	SCOUR CRITICAL	EFFECTIVE DATE	VERIFIED NO CHANGE 1R	
018	35.98	02073C	Salmon Creek, Hwy 18	1991	218	69.3	6 Satisfactory	69.3	78.6	9 MS 22.5 (HS 25)	ND	7 Good	1 Concrete-Cast-in-Place	7 Good	7 Countermeasures	2017	No	inside CL
018	37.09	20359	Hwy 18 over Private Logging Road	2008	118	44	7 Good	44	79.41	H193	ND	8 Very Good	1 Concrete-Cast-in-Place	8 Very Good	N Not Over Waterway	2017	No	outside CL
C0000	0.10	19020	Crestview St over UPRR	1972	325	29.8	6 Satisfactory	29.8	81.1	5 MS 18 (HS 20)	ND	7 Good	1 Concrete-Cast-in-Place	6 Satisfactory	N Not Over Waterway	2017	No	inside CL
C0000	0.10	39C626	Salmon Creek, Salmon Creek Road	1966	327	39	6 Satisfactory	39	92.8	6 MS 18 (HS 20)	ND	6 Satisfactory	2 Concrete-Cast-in-Place	6 Satisfactory	3 SC - Unstable	2017	No	



Volume II – Appendix E  
**Technical Memorandum #5**

# MEMORANDUM #5

**Date:** July 15, 2019

Project #: 22477

**To:** Rick Zylstra (City of Oakridge)  
David Helton (Oregon Department of Transportation)

**From:** Ashleigh Ludwig, PE, Marc Butorac, PE and Jacki Gulczynski

**Project:** City of Oakridge Transportation System Plan Update

**Subject:** Proposed Transportation System Improvements

## INTRODUCTION

This memorandum provides an overview of the potential solutions evaluated for the Oakridge Transportation System Plan (TSP) Update. The memo includes recommended projects, policies, programs, pilot projects, and studies to address needs identified in *Technical Memorandum #4 -Transportation System Conditions, Deficiencies, and Needs*.

In addition, projects included in the 2000 Oakridge TSP and 2016 Oakridge Pedestrian Safety Plan were reviewed for completion or continued viability. Completed projects were removed from the project list, and remaining projects were either carried forward to the recommended project list in this TSP or removed if no longer relevant. Appendix A provides a summary of the 2000 TSP projects, indicating whether they were completed, removed, or carried forward.

## TABLE OF CONTENTS

<b>INTRODUCTION .....</b>	<b>1</b>
<b>TABLE OF CONTENTS .....</b>	<b>1</b>
Needs and Solutions.....	2
Street System Solutions.....	2
Functional Classification Map Updates .....	2
Typical Street Cross sections .....	6
Freight System .....	15
Intersection/Roadway Solutions .....	18
Paving Improvements .....	26
Safety Solutions .....	28
Pedestrian System Solutions .....	38
Bicycle System solutions.....	43
Transit System Solutions .....	46
Rail and Air System Solutions.....	49
OR 58 Solutions .....	51
<b>APPENDICES .....</b>	<b>58</b>

---

## NEEDS AND SOLUTIONS

---

Project needs and potential solutions are described below. Cost estimates and funding opportunities for these projects will be presented in Technical Memorandum #6: *Costs and Potential Funding Strategies for Proposed Improvements*. It should be noted that the highway, bike lane, sidewalk, crosswalk, and transit amenity design elements depicted for state facilities are identified for discussion and planning purposes and for determining a reasonable planning cost estimate only. The actual design elements for any state facility are subject to change, will ultimately be determined through a preliminary and final design process, and are subject to ODOT approval.

Potential projects have been identified as planning horizon or visionary. Planning horizon projects are needed to address needs within the 20-year planning horizon and will be carried forward in the prioritization process. Visionary projects are idealistic, long range in nature, and may not have operational or safety data supporting them within the 20-year planning horizon. These projects are included to illustrate the long-range vision of the City and may become higher priority with future changes in land use, transportation, or funding opportunities. *Visionary projects will be identified by an asterisk next to the project ID.* Potential solutions are presented in the following sections:

- ▶ Street System
- ▶ Safety
- ▶ Pedestrian System
- ▶ Bicycle System
- ▶ Transit System
- ▶ Rail and Air System
- ▶ OR 58

---

## STREET SYSTEM SOLUTIONS

---

The Transportation System Conditions, Deficiencies, and Needs Memorandum (Technical Memorandum #4) described the operational analysis conducted at seven study intersections and four study segments within the Oakridge community. The analysis of existing and projected future conditions found that the study intersections are expected to meet the respective jurisdictional motor vehicle operational standards in year 2040. Based on these results, no motor vehicle capacity improvements are suggested at this time.

Although no capacity needs were identified, several motor vehicle system needs were identified based on the analysis of existing and future conditions, project advisory committee feedback, and public input from the open house. These system needs are described in the following sections.

### FUNCTIONAL CLASSIFICATION MAP UPDATES

Technical Memorandum #4 identified the need to update the City's functional classification system to create a continuous non-highway east-west route through the City and to modify the classification of several roadway segments to reflect their current and/or envisioned future purpose. Modifying the functional classification system does not require the City to reconstruct the road immediately. However, future projects on these facilities would need to be built according to the adopted functional classification and respective standards.

Updates to the functional classification map are proposed based on comments received from the project advisory committee and the public and an assessment by the project team to create properly classified street system within the City. Figure 1 shows the proposed updated roadway functional classification map and Table 1 summarizes and provides the justification for the proposed update. Roadways with a proposed functional classification change are shown as a dashed line in Figure 1.



As shown in the figure, the major and minor collector designations have been combined as “collector”. In the 2000 TSP, the only difference between the cross sections for a major and minor collector are the optional presence of a bicycle lane. However, the Oregon Transportation Planning Rule (TPR) requires bikeways along arterials and collectors. Therefore, the major and minor collector designations have been combined for simplification.

A minor and major arterial designation was also implemented. OR 58 is the primary east-west route through the City and therefore requires a standalone designation (major arterial). The Crestview Street, E 1<sup>st</sup> Street, Oak Street, Westoak Street route was classified as a minor arterial because this is a primary north-south route and provides a connection to Westfir and the County.

Additionally, low volume access streets were separated into two designations: local and shared street. A local street emphasizes access over mobility. It typically provides access to destinations such as residences. Local streets may provide a connected network to other low-volume, low speed roadways. Shared streets are slow-speed roadways shared by pedestrians, cyclists, and vehicles that typically only provide access to end of trip destinations. Figure 1 illustrates both local and shared street designations.

**Table 1. Proposed Functional Classification Updates**

Project ID	Proposed Modification	Justification for Proposed Modification
FC-1	Downgrade W 2nd Street to a collector	Downgrade W 2nd Street between Union Street and Portal Drive from an arterial to a collector. W 2nd Street currently has inconsistent classification; the road is designated as a collector on all other segments.
FC-2	Downgrade E 1st street to a collector	Downgrade E 1st Street east of Oak Street from an arterial to a collector to provide consistency throughout the network as E 1st Street has lower volumes east of Oak Street and the Uptown area.
FC-3	Downgrade Commercial Street to a collector	Downgrade Commercial Street between W 2nd Street to 250 feet south of W 1st Street from an arterial to a collector. This is a complimentary east-west connection to 1st Street.
FC-4	Downgrade Garden Road to a local street	Downgrade Garden Road south of School Street from a major collector to a local street. Garden Road is primarily a low volume, residential roadway.
FC-5	Downgrade Rainbow Street to a local street	Downgrade Rainbow Street between OR 58 and Fairyglen Drive from major collector to a local street. Rainbow Street is not connected to a network of collectors and primarily serves residential access.
FC-6	Downgrade Rock Road to a local street	Downgrade Rock Road between OR 58 and Berry Street from minor collector to a local street. Rock Road is not connected to a network of collectors and serves residential access only.
FC-7	Upgrade Industrial Park Way to a collector	Upgrade Industrial Park Way between Mill Pond to Fish Hatchery Road (the gravel portion of Industrial Park Way from Fish Hatchery Road to approximately 1,500 feet west) from a local, unpaved road to a collector. This is a primary route through the industrial park that connects to two high order facilities (OR 58 and Fish Hatchery Road).
FC-8	Downgrade Union Street to a local street	Downgrade Union Street between OR 58 and W 2nd Street from a minor collector to a local street. Union Street is primarily a low volume, residential roadway.
FC-9	Upgrade Fish Hatchery Road to a collector	Upgrade Fish Hatchery Road between OR 58 and E 1st Street from a local road to a collector to provide higher order north-south connection on the east side of the City and in the industrial park. A small section of this road, at the north end, extends outside of the City limits; coordination with the County's TSP should occur to provide a consistent system.
FC-10	Downgrade Portal Drive to a local street	Downgrade Portal Drive between W 2nd Street and Commercial Street from an arterial to a local. This is a low volume, residential route.
FC-11	Downgrade Poplar Street to a local street	Downgrade Poplar Street between W 2nd Street and Commercial Street from a minor collector to a local street. This is a low volume, residential route.

H:\22\2477 - Oakridge TSP Update\GIS\Memo 5 - Alternatives\01 Proposed Functional Classification Map.mxd - jsomerville - 1:16 PM 5/6/2019



	Major Arterial		Proposed Minor Arterial
	Minor Arterial		Proposed Collector
	Collector		Proposed Local
	Local		Parks
	Shared Street		Oakridge City Boundary
			Urban Growth Boundary

**Proposed Functional Classification Map  
Oakridge, Oregon**

**Figure  
1**

## TYPICAL STREET CROSS SECTIONS

The City of Oakridge has street design standards that vary based on the roadway's designated functional classification. The City's cross section requirements include some options to allow flexibility for responding to unique conditions or constraints.

*The Accessible Sidewalk and Street Crossing* guide developed by the Federal Highway Administration<sup>1</sup> provides guidance for state and local facilities to meet the needs of all sidewalk users including children, senior citizens, and people with disabilities. Guidance suggests the pedestrian travel zone (area of the sidewalk specifically reserved for pedestrian travel) should never be less than 4 feet, however, 6 feet is the minimum width that comfortably allows two people to walk side by side or pass if going the opposite direction. A 6-foot sidewalk is also the minimum width that allows two wheelchairs to pass one another. A landscaping buffer between the sidewalk and the street provides additional separation between motorists and pedestrians while also providing a guide cue for pedestrians with vision impairments.

The 2000 TSP standards shows a 5.5-foot wide sidewalk for collectors and local streets, slightly less than the Oregon guidance for state facilities and the FHWA guidance. The recommendation is to provide a minimum sidewalk standard width of 6 feet.

When roads are constructed or reconstructed in Oakridge, the roadway cross section should be built to the standards identified in the TSP and adopted by the City. Figures 2 through 4, along with Table 2, propose the minimum right-of-way width, pavement width, and multimodal accommodations based on functional classification. Where it can be demonstrated that topographic conditions or existing development preclude building to the standard, the Public Works Director may allow a modified cross section for some constrained roadways. Additionally, ODOT maintains its own cross section standard that guides the cross section for OR 58.

---

<sup>1</sup> [http://www.bikewalk.org/pdfs/sopada\\_fhwa.pdf](http://www.bikewalk.org/pdfs/sopada_fhwa.pdf)

**Table 2. Proposed Typical Street Cross section Standards\***

Street Functional Classification		Right-of-way	Pave-ment Width	Sidewalk Width	Bike Lane Width	Parking	Landscape Strip	Applicable Roads
Minor Arterial	Option A	60ft	48ft	6ft	6ft	7 ft	None	All, unless noted under Option B
	Option B	60ft	22ft	8ft path	None	None	5ft	Westoak Road, Crestview Street
	Option C	60ft	41ft	6ft	6ft	7 ft one side	None	1 <sup>st</sup> Street
Collector	Option A	60ft	46ft	6ft	6ft	7ft	None	All with parking, unless noted below in Options C or D
	Option B	60ft	39ft	6ft	6ft	7 ft one side	None	Hills Street, Beech Street
	Option C	60ft	32ft	6ft	6ft	None	None	All without parking, unless noted below in Options D or E
	Option D	60ft	32ft	6ft one side	6 ft	None	None	W 2 <sup>nd</sup> Street (between Teller Road and Commercial Street)
	Option E	60ft	20ft	8ft path	None	None	5ft	Fish Hatchery Road; Industrial Park Way; E 1 <sup>st</sup> Street east of city boundary; High Prairie Road
Local	Option A	60ft	34ft	6ft	None	7ft	None	All with parking, unless noted in Options C or D
	Option B	60ft	20ft	6ft	None	None	None	All without parking, unless noted in Options C or D
	Option C	60ft	34ft	6ft	6ft	None	None	Garden Road (first 400 ft south of School Street); Rainbow Road (first 300 ft south of OR58)
	Option D	60ft	20ft	8ft path	None	None	5ft	Garden Road, Fairyglen Drive, Rainbow Street, Union Street
Shared Street	-	60ft	20ft	None	None	None	None	All

\*Cross section options are shown in Figures 2 through 4

### Minor Arterial Cross Section - Option A

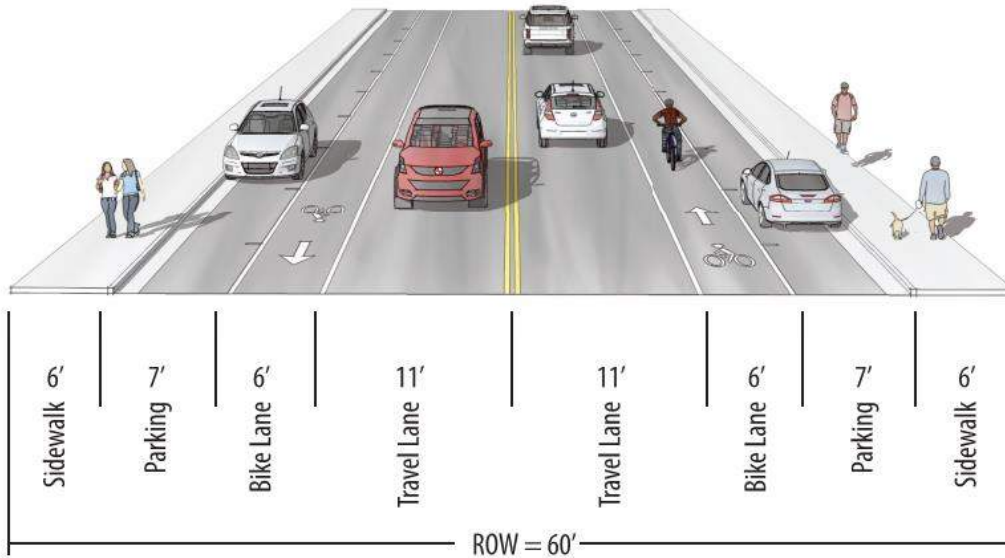
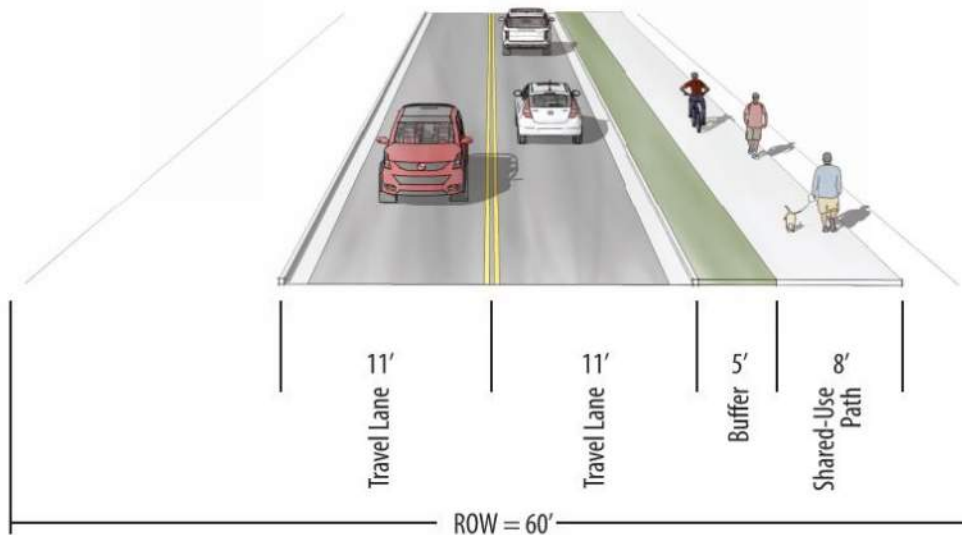

Figure 2A. Minor Arterial Cross section Option A

### Minor Arterial Cross Section - Option B



Note: Landscape buffer may be eliminated on the Crestview Street bridge to fit within existing structure.

Figure 2B. Minor Arterial Cross section Option B

### Typical Minor Arterial Cross Section - Option C

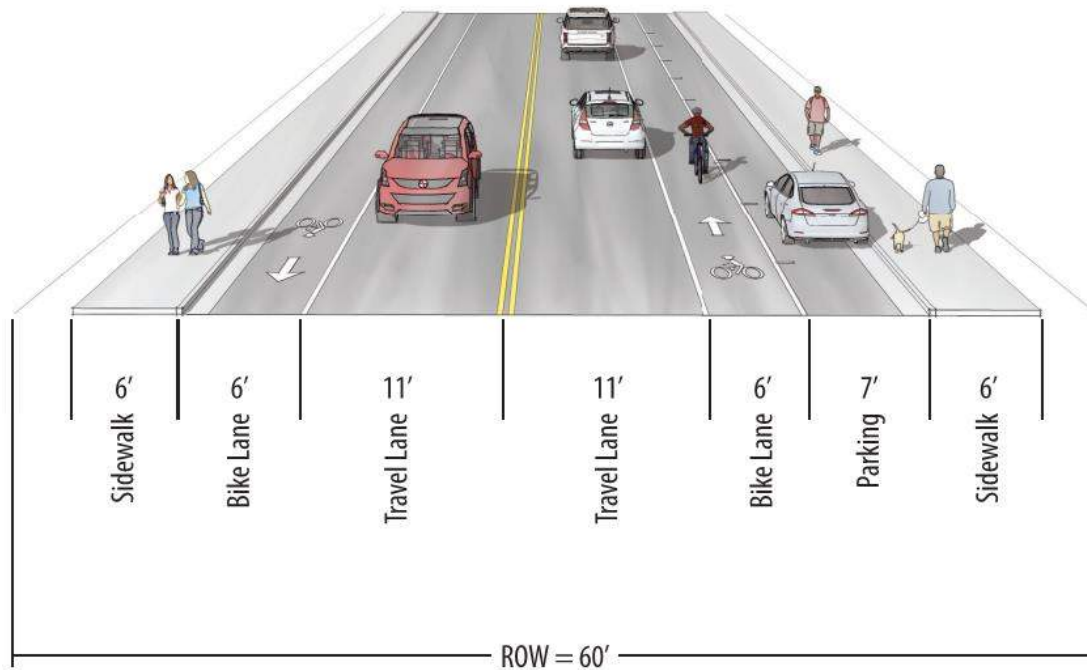

Figure 2C. Minor Arterial Cross section Option C

### Typical Collector Cross Section - Option A

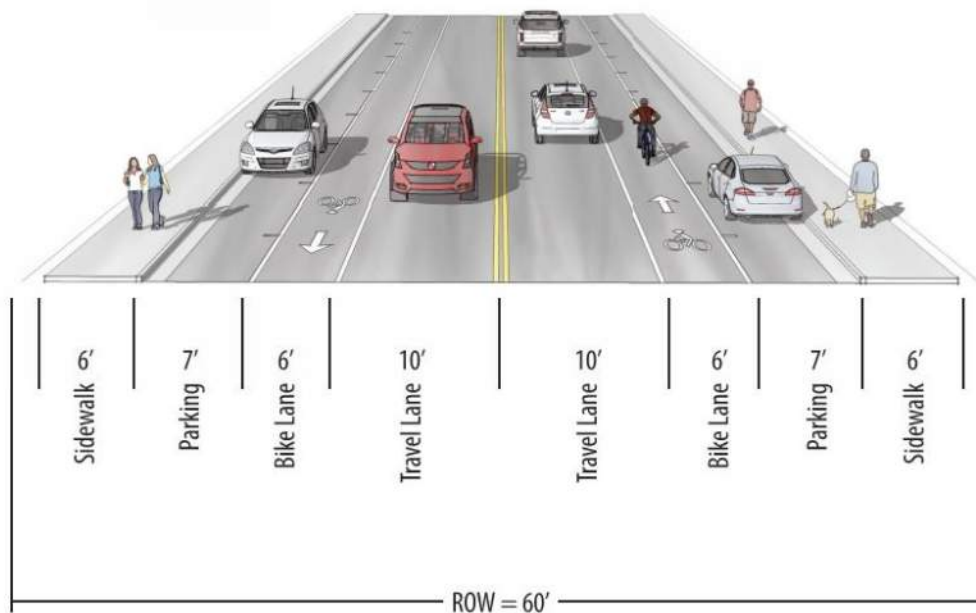

Figure 3A. Collector Cross section Option A

### Typical Collector Cross Section - Option B

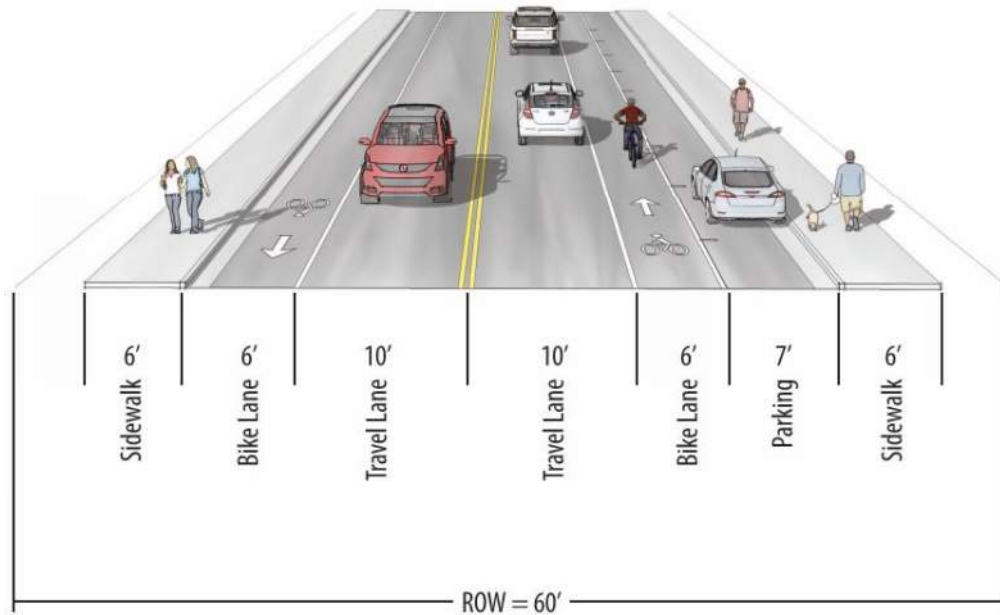

Figure 3B. Collector Cross section Option B

### Typical Collector Cross Section - Option C

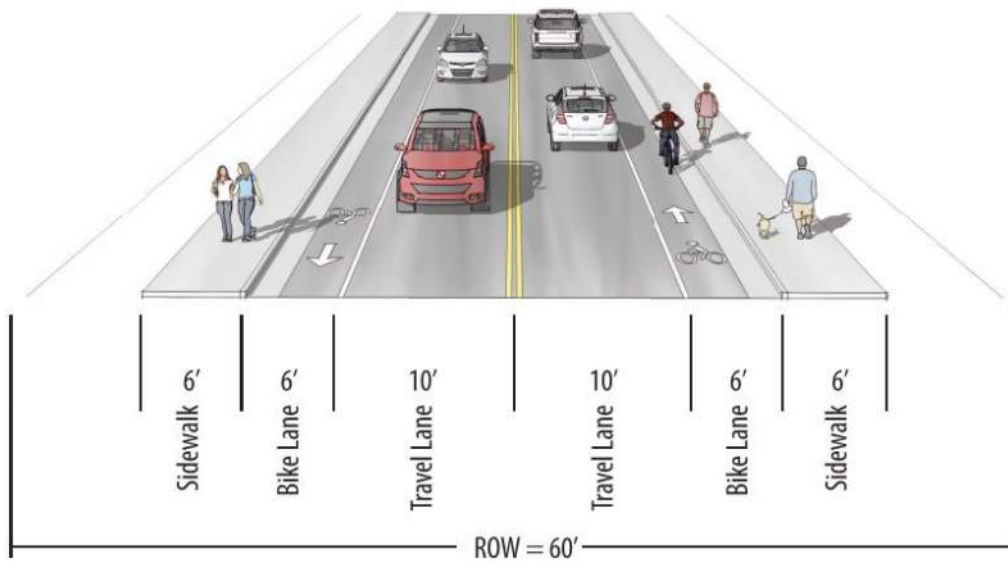

Figure 3C. Collector Cross section Option C



### Typical Collector Cross Section - Option D

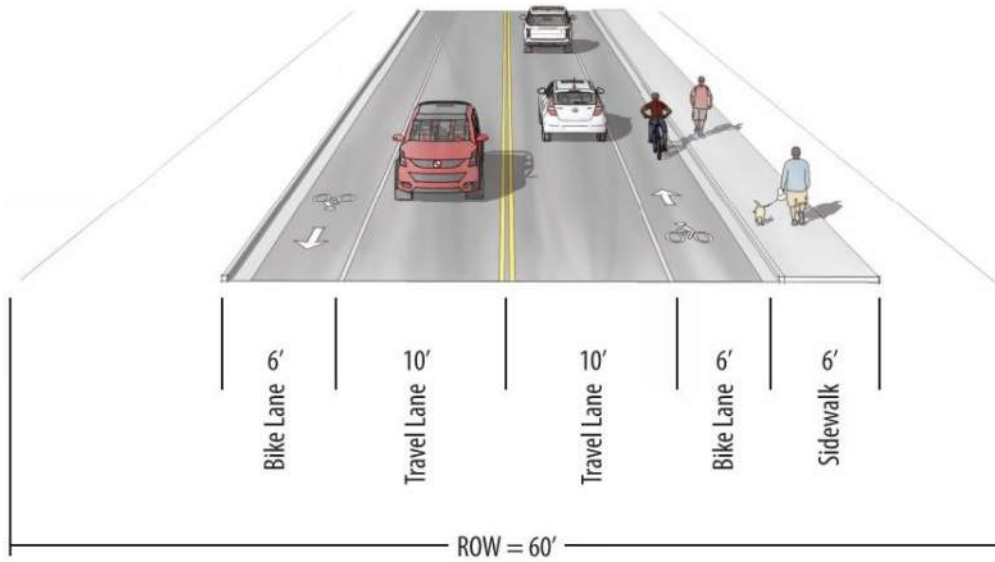

Figure 3D. Collector Cross section Option D

### Typical Collector Cross Section - Option E

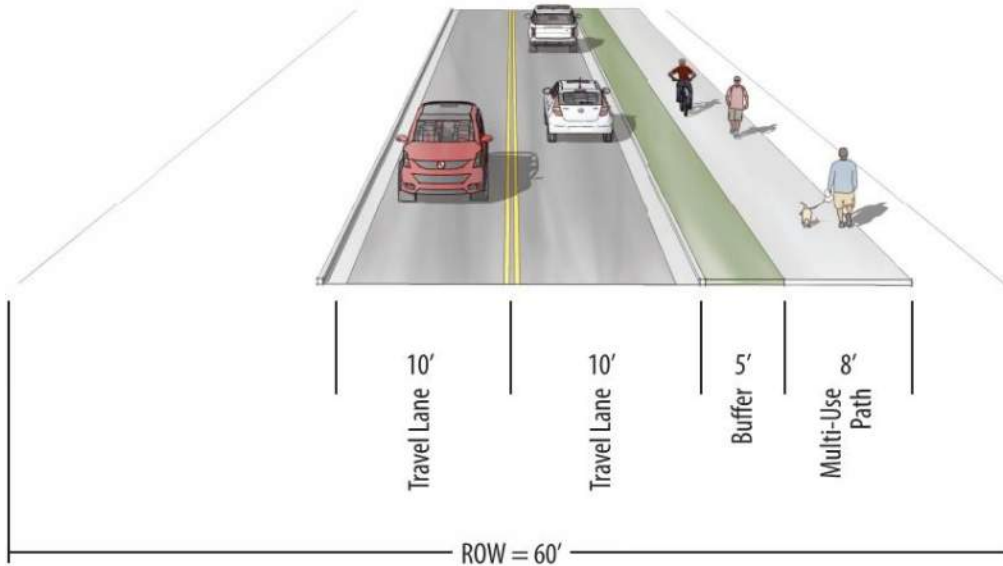

Figure 3E. Collector Cross section Option E

### Typical Local Section - Option A

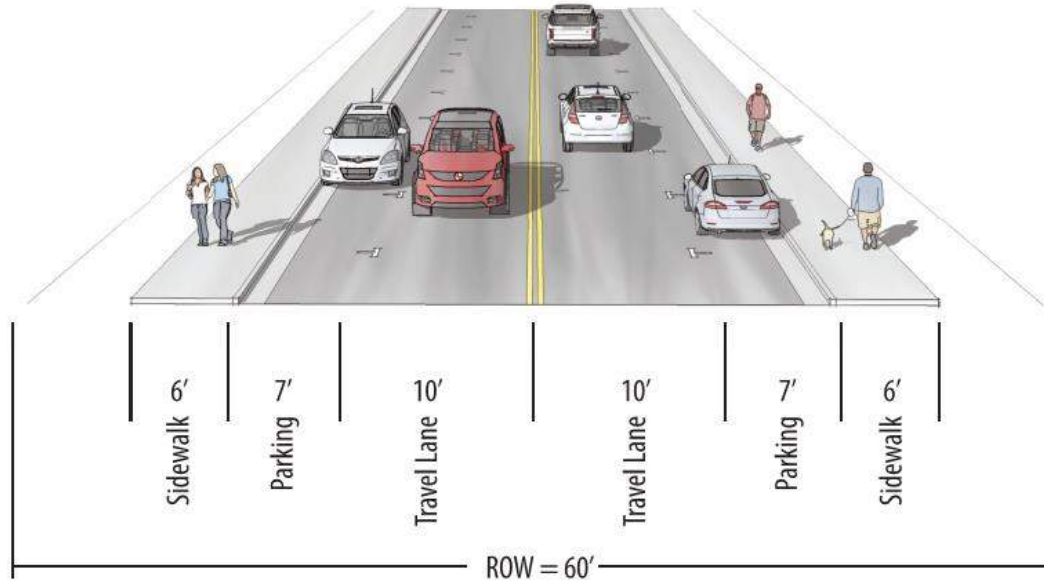

Figure 4A. Local Cross section Option A

### Typical Local Section - Option B

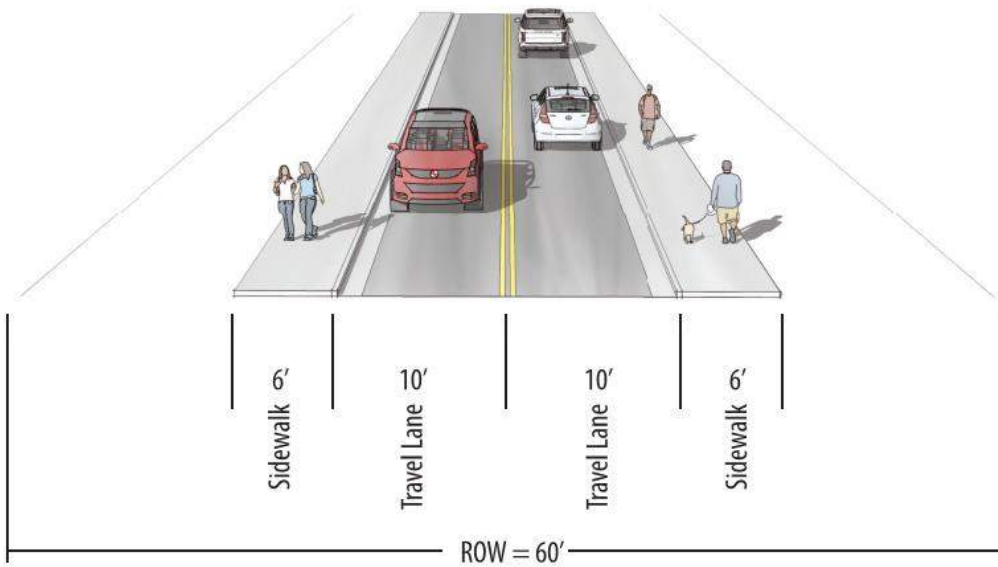

Figure 4B. Local Cross section Option B

### Typical Local Section - Option C

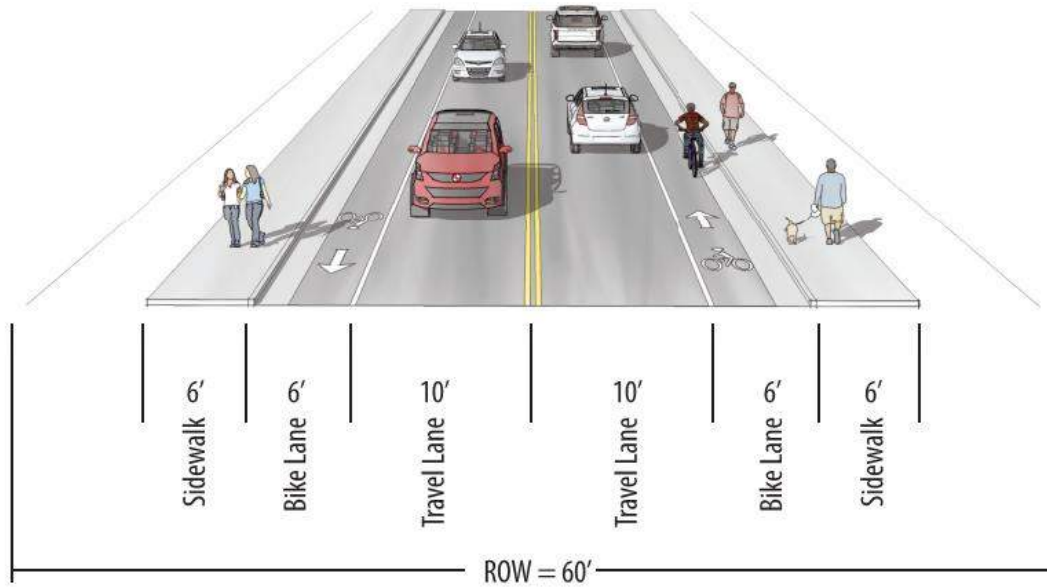

Figure 4C. Local Cross section Option C

### Typical Local Section - Option D

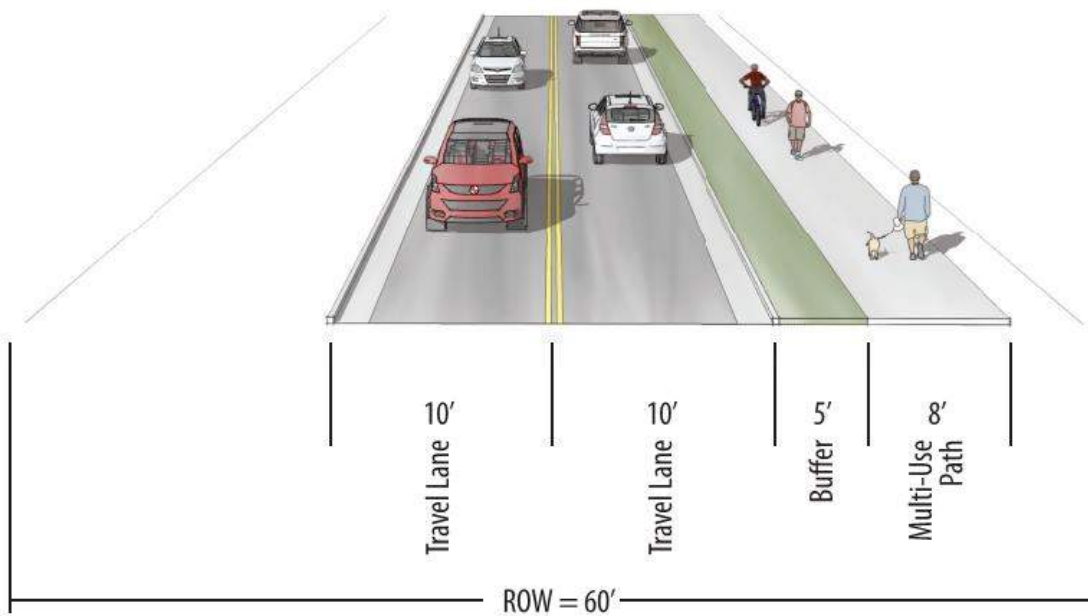

Figure 4D. Local Cross section Option D

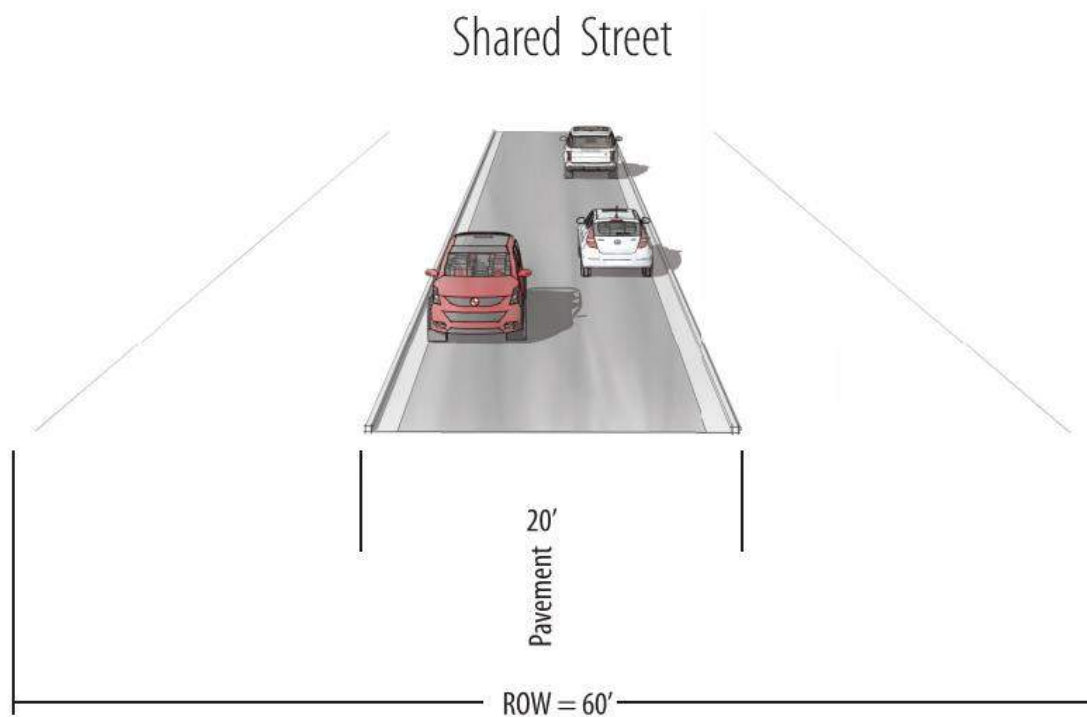

Figure 4F. Shared Street Cross section

## Access Management

### ODOT Standards

ODOT specifies access management spacing standards in the Oregon Highway Plan (OHP) and OAR 734-051-4020(8). The applicable access management spacing standards for OR 58 within the Oakridge UGB are summarized in Table 3. These standards are based on the 2018 AADT (Annual Average Daily Traffic volume), posted speed limit, and highway designation. Access spacing requirements are not currently met at many locations along OR 58 in Oakridge.

**Table 3. OR 58 Access Spacing Requirements**

Segment	Posted Speed	Spacing
Western City Limits to Hyland Lane	35mph	500 ft
Hyland Lane to Industrial Park Way	45mph	800 ft
Industrial Park Way to Fish Hatchery Road	55mph	1320 ft

### City of Oakridge Standards

The City's access spacing standards are intended to maintain and enhance the integrity (capacity, safety, and level of service) of city streets. Numerous driveways or street intersections increase the number of conflict points and potential for collisions and decrease mobility and traffic flow. Table 4 summarizes the City's access spacing requirements.

In cases where physical constraints or characteristics limit the ability to achieve the access spacing standards, the City of Oakridge retains the right to grant an access spacing variance. Within the UGB, Lane County applies the City's access management standards as well.

**Table 4. Citywide Access Spacing Requirements**

Functional Classification	Spacing
Minor Arterial	150 ft
Collector	50 ft
Local Street	25 ft
Shared Street	25 ft

## FREIGHT SYSTEM

Table 5 presents the freight solutions developed to address the needs identified in Tech Memo #4. The proposed freight projects and studies include providing a local freight route within the community to serve the industrial park, Union Pacific Railroad facility, and the uptown area. Figure 5 shows the recommended local freight route. Designating a local freight route illustrates the preferred route for trucks and allows the City to restrict other routes from through-traffic. However, trucks must still be able to use other routes to access their destination when needed. OR 58 is a part of the statewide freight system and designated as a Reduction Review Route, which is an "ODOT facility that requires review during planning, project development, development review, and maintenance to examine its 'hole in the air' capacity." The "hole in the air" refers to ODOT state law<sup>2</sup> describing the need to accommodate legal loads and annual permitted over-dimensional loads. OR 58 is a reduction review route freight route, it is also constrained with an Over-Dimensional Load Pinch Point. The Salt Creek tunnel, located approximately

<sup>2</sup> Oregon Revised Statute 366.215

20 miles east of Oakridge, is a 914-foot-long tunnel that is 27 feet wide and 18 feet tall<sup>3</sup>. Over-dimensional loads with a height restriction greater than 18 feet may be required to use an alternate route. Wide loads, requiring the use of more than one lane, would require flaggers and must not exceed 27 feet. Therefore, the “hole in the air” capacity that is relevant for OR 58 is based on the size constraints at the Salt Creek Tunnel.

The community and advisory committee identified a potential need for a weigh station, truck parking area, and/or a commercial truck stop in or near Oakridge to serve trucks traveling between Eugene and Central Oregon. Currently, there are limited locations for trucks to stop along OR 58. These projects have the potential to support economic development in Oakridge. Feasibility studies are recommended to evaluate the feasibility and cost of constructing a weigh station, truck parking accommodations (daytime/overnight, and a commercial truck stop.

**Table 5. Proposed Freight Solutions**

Project ID	Project Name	Project Description	Location
FR-1	Designated Local Freight Route	Provide a designated local freight route that includes Fish Hatchery Road, E 1 <sup>st</sup> Street, and Crestview Street.	Fish Hatchery Road, E 1 <sup>st</sup> Street, Crestview Street
FR-2	Weigh Station Feasibility Study	Conduct a feasibility study to identify the need and viability of a weigh station for heavy vehicles on the eastside of Oakridge using Oakridge's existing (inactive) weigh station.	Determined by study
FR-3	Truck Parking Feasibility Study	Conduct a feasibility study to identify the need and viability of constructing a truck parking area for heavy vehicles within Oakridge.	Determined by study
FR-4	Commercial Truck Stop	Conduct a feasibility study to identify the need and viability of constructing a commercial truck stop center within Oakridge.	Determined by study

<sup>3</sup> Data provided by ODOT TransGIS (<https://gis.odot.state.or.us/transgis/>)



- Freight Projects
- Parks
- Oakridge City Boundary
- Urban Growth Boundary

**Freight Projects  
Oakridge, Oregon**

**Figure  
5**

H:\22\22477 - Oakridge TSP Update\GIS\Memo 5 - Alternatives\05 Freight\Projects.mxd - jsmmerville - 1:14 PM 4/10/2019

## INTERSECTION/ROADWAY SOLUTIONS

Table 6 provides a summary of the proposed intersection and roadway solutions. This list includes corridor upgrades, road closures, and illumination projects. These projects are included to improve the overall road system for all users. As identified in Technical Memorandum #4, no operational capacity issues are expected in the system within the planning horizon. Therefore, these improvements were identified to address multimodal, connectivity, and/or safety needs. Figure 6 shows the locations of the intersection and roadway improvements. Proposed roadway projects R-6 and R-7 apply to OR 58 and are further described in the OR 58 section of the memo.

**Table 6. Proposed Intersection/Roadway Solutions**

Project ID	Project Name	Project Description	Location
R-1	E 1 <sup>st</sup> Street Uptown Corridor Refinement	Reconfigure E 1 <sup>st</sup> Street to include bike lanes on both sides and convert the existing angled parking to parallel parking on south side. Add bike lanes on E 1 <sup>st</sup> Street west of Hazel Street and restrict parking to one side of the road.	E 1 <sup>st</sup> Street from Poplar Street to City limits
R-2	Greenwaters Park Illumination	Illuminate the intersection of OR 58/Greenwaters Park and provide illumination along the road leading to the parking lot.	Greenwaters Park
R-3	E 2 <sup>nd</sup> Street Road Closure	Close E 2 <sup>nd</sup> Street to eliminate the sight distance constraints at the skewed intersection of E 2 <sup>nd</sup> Street/Westoak Road. Reroute vehicles to Oak Street.	E 2 <sup>nd</sup> Street between Westoak Road and Beech Street
R-4	Crestview Street Cross section and Multimodal Improvements	Improve the Crestview Street cross section to accommodate shared-use path on the east side by reducing travel lane widths.	Crestview Street from OR 58 to E 1 <sup>st</sup> Street
R-5	OR 58 Illumination	Provide illumination along OR 58.	OR 58 from Hills Street to Hyland Lane
R-6	OR 58 Street Reconfiguration Pilot Project	Implement a temporary lane reconfiguration on OR 58	OR 58 from Thatcher Lane to Jones Road
R-7*	Long Term OR 58 Street Reconfiguration Project	Reconfigure the highway's cross section to accommodate one lane in each direction with multimodal facilities, based on results of pilot project.	OR 58 (determined by study)

\*Visionary project



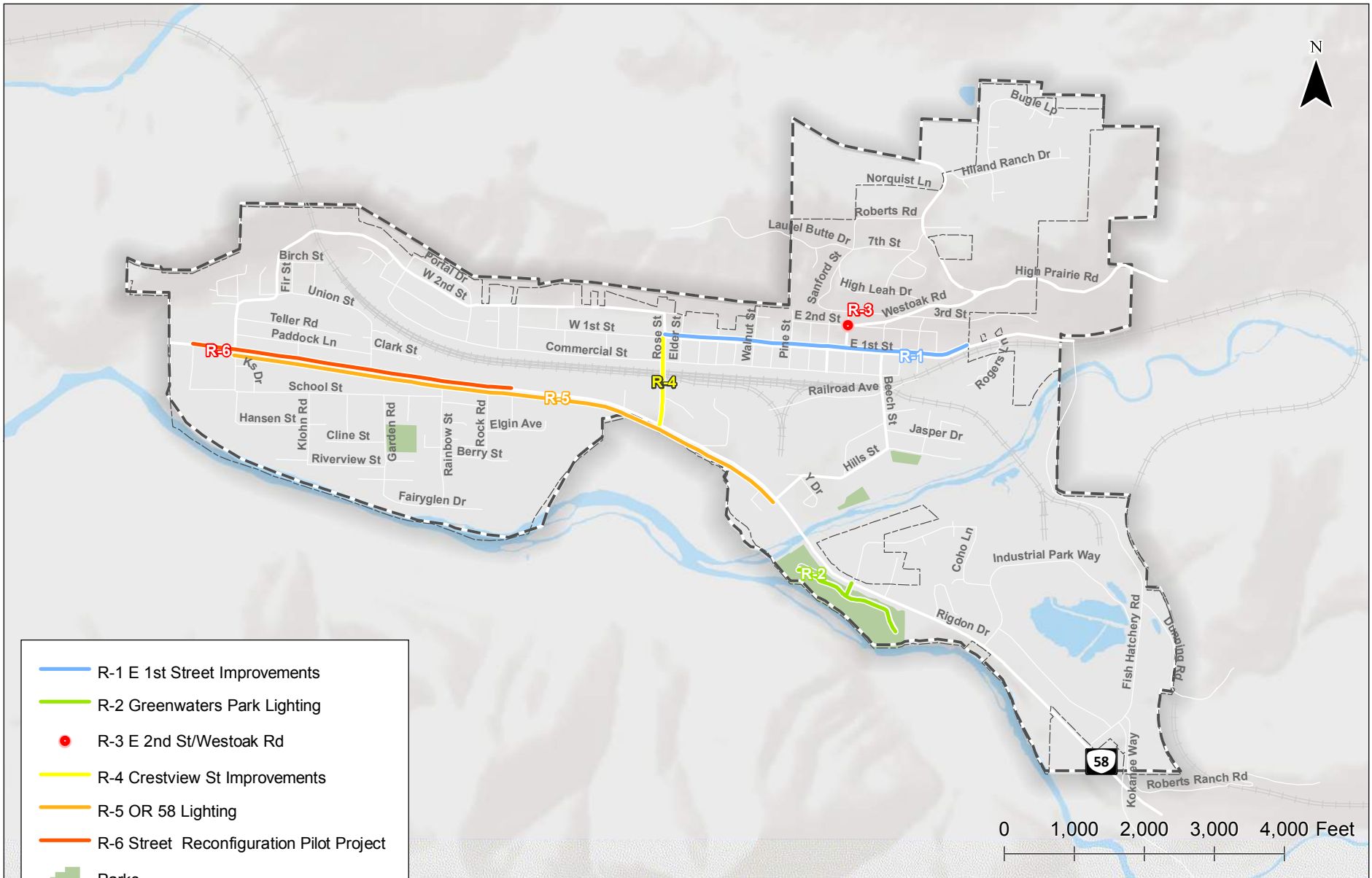

**Roadway Projects  
Oakridge, Oregon**

**Figure  
6**

H:\22\2477 - Oakridge TSP Update\gis\Memo 5 - Alternatives\07 Roadway Projects.mxd - jguczynski - 4:42 PM 3/21/2019

## E 1<sup>st</sup> Street Uptown Corridor Refinement (R-1)

The E 1<sup>st</sup> Street uptown corridor provides access to local businesses while also providing connections to the schools to the west and popular trails to the east. E 1<sup>st</sup> Street between Pine Street and Beech Street currently consists of parking on both sides of the road and curb tight sidewalks but no bicycle lanes. The parking on the north side is parallel parking, and the south side has angled parking.

The proposed corridor project includes reconfiguration of the existing pavement width to provide bicycle lanes, as required by the minor arterial roadway cross section and shown in the proposed Bicycle Solutions section, by reconfiguring the angled parking to parallel parking on the south side of the road and narrowing existing travel lane widths. Additionally, parallel parking spaces should be striped between Hazel Street and Pine Street on both sides of the roadway to provide additional on-street parking spaces. Figure 7 shows the recommended cross section for E 1<sup>st</sup> Street in the uptown area between Hazel Street and Beech Street. There are some sidewalks on E 1<sup>st</sup> Street that exceed the typical cross section sidewalk width of 6 feet for a minor arterial. In locations where the sidewalk is wider than 6 feet the width should be maintained when possible.

To accommodate the bike lanes, the parking on the southside must be converted from angled parking to parallel parking. This reconfiguration also addresses the resident's safety concern associated with difficulty seeing oncoming vehicles and bicyclists when backing out of angled parking spaces. This will result in a loss of approximately 35 parking spaces on E 1<sup>st</sup> Street between Hazel Street and Beech Street. If the City wishes to replace some of these spaces by adding on-street parking on side streets such as Oak Street, additional roadway projects may be needed to widen or pave these roads to accommodate more on-street parking.

In addition to striping updates, the City may consider constructing curb extensions or "bulb-outs" on the corners of the intersections in the Uptown Area. Bulb-outs extend the sidewalk into the parking lane to narrow the crossing distance for pedestrians and improve the visibility of pedestrians at intersections. Curb extensions also act as a traffic calming measure and reduce the turning movement speeds at intersections. This feature should be considered as part of the design and implementation of a 1<sup>st</sup> Street corridor plan.

Outside of the uptown area, west of Hazel Street and east of Beech Street, the existing pavement width narrows to approximately 42 feet. The existing cross section includes unmarked, parallel parking on both sides of the road. In order to accommodate bicycle lanes in both directions, as shown in the typical cross section for arterials, parking will need to be restricted on one side of the road. This restriction would result in the loss of approximately 80 parking spaces west of Hazel Street and east of Beech Street. Figure 8 shows a layout of what is proposed in the 1<sup>st</sup> Street Corridor Refinement by location including bike lanes, parallel parking on the southside of 1<sup>st</sup> Street in the Uptown area, and parking restricted to one side of the road on 1<sup>st</sup> Street west of Hazel Street. Providing bicycle lanes on 1<sup>st</sup> Street creates a key, citywide east-west network. A connected citywide multimodal network not only provides options and amenities for residents, but also provides opportunities for tourists and visitors to navigate the city via biking and walking.

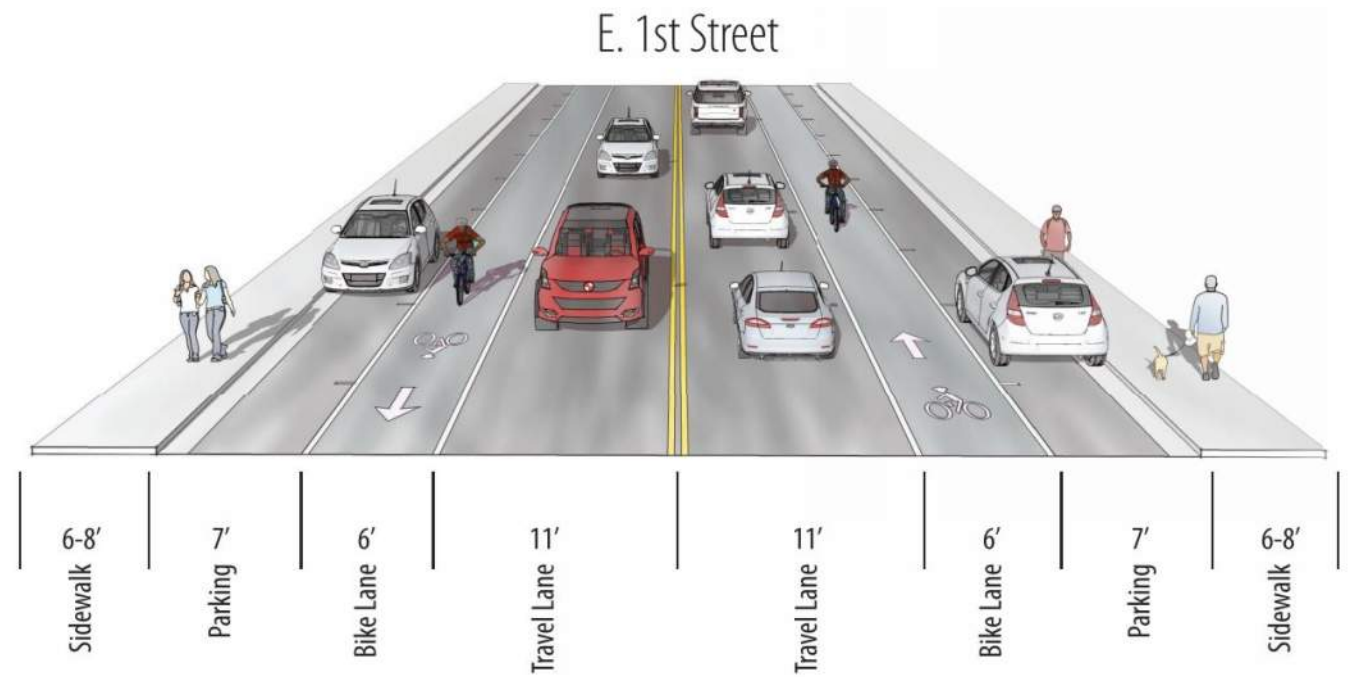
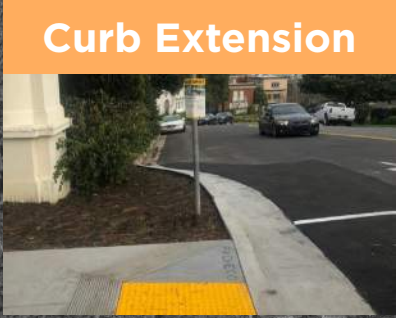
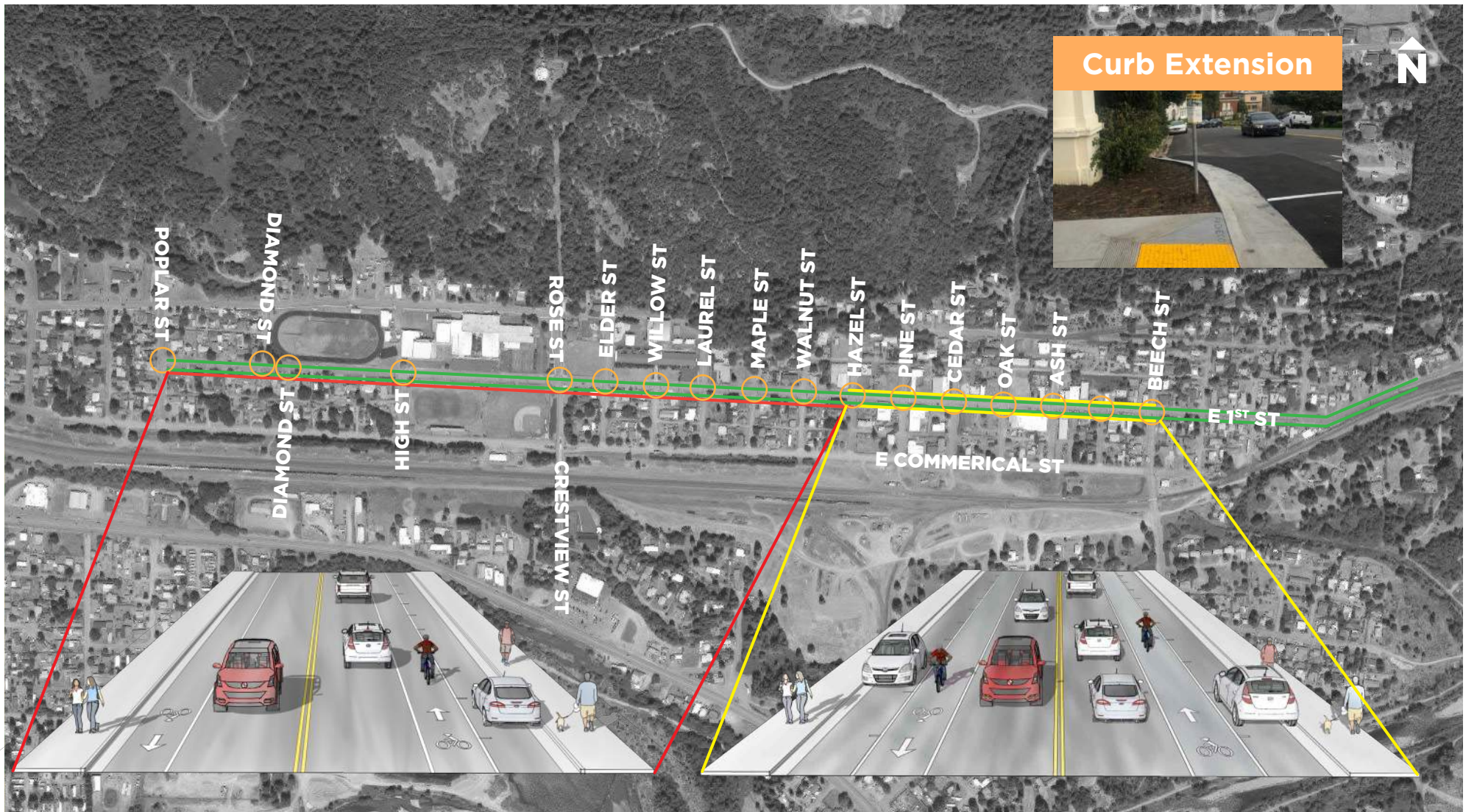

Figure 7. Proposed E 1<sup>st</sup> Street Cross Section between Hazel Street and Beech Street



- Bike Lanes
- Parallel parking
- Curb Extensions
- Restrict parking to northside only on 1<sup>st</sup> Street

## Greenwaters Park Illumination (R-2)

Greenwaters Park is a popular recreational destination for residents and visitors. The Greenwaters Park bridge crossing the Willamette River provides access to numerous popular mountain biking and hiking trails. The park is accessed from OR 58 on the east side of town at the intersection of OR 58/Hyland Lane. The intersection has limited lighting with a single luminaire located on the south side of the intersection. There is currently no street lighting along the road within the park that leads to the Greenwaters parking area. For the safety and comfort of those using the park, installation of street lighting is recommended at the intersection of OR 58/Hyland Lane and along the roadway from the highway to the park.

## E 2<sup>nd</sup> Street Road Closure (R-3)

The intersection of E 2<sup>nd</sup> Street and Westoak Road is currently stop controlled for the westbound movement of E 2<sup>nd</sup> Street. The intersection is set at a significant skew with a substantial grade differential, particularly on the E 2<sup>nd</sup> Street approach. The skew and grade restrict sight distance for westbound vehicles on E 2<sup>nd</sup> Street. Additionally, those coming south from Westoak Road attempting to turn left onto E 2<sup>nd</sup> Street must complete a movement that is almost as tight as a U-turn.

While there were no reported crashes at the intersection during the study period, the skew, grade, limited sight distance, and challenging turning movements create a safety concern – especially during adverse weather or nighttime conditions. The closure of E 2<sup>nd</sup> Street is recommended between Westoak Road and Beech Street. Vehicles would be rerouted to E 1<sup>st</sup> Street and Oak Street, as shown in Figure 9. Beech Street is currently one-way in the southbound direction and approximately 15 feet wide between E 2<sup>nd</sup> Street and E 1<sup>st</sup> Street. This segment of Beech Street will need to be widened accommodate two-way travel.



Figure 9. E 2<sup>nd</sup> Street Road Closure

## Crestview Street Cross Section and Multimodal Improvements (R-4)

Crestview Street is a primary north-south arterial in Oakridge. It is the only grade separate rail crossing in the City and provides connections between OR 58 and the local schools. With limited crossing opportunities, Crestview Street must accommodate vehicles, pedestrians and cyclists. The existing cross section on the railroad bridge consists of two, 15-

foot travel lanes, a concrete barrier, and a narrow pedestrian path, approximately five feet wide. To better facilitate all users, the cross section shown in Figure 10 is recommended for the bridge crossing of Crestview Street. This cross section reduces the width of the travel lanes while providing a larger shared-use path for multimodal users. This cross section can be accomplished within the existing width of the structure by relocating the concrete barrier further west; however, the initial design phase of the project must evaluate the structure to determine whether the existing sidewalk on the bridge is part of the original structure or an add-on. This will impact the complexity and cost of the project.

The remaining section of Crestview Street, between OR 58 and E 1<sup>st</sup> Street, should continue the 10-foot path on the east side of the street to provide a complete connection for pedestrians and bicyclists. While the cross section of the bridge will meet most components of the Minor Arterial Option B, there the width of the bridge will not accommodate a landscape strip.



### Crestview St Lane Conversion

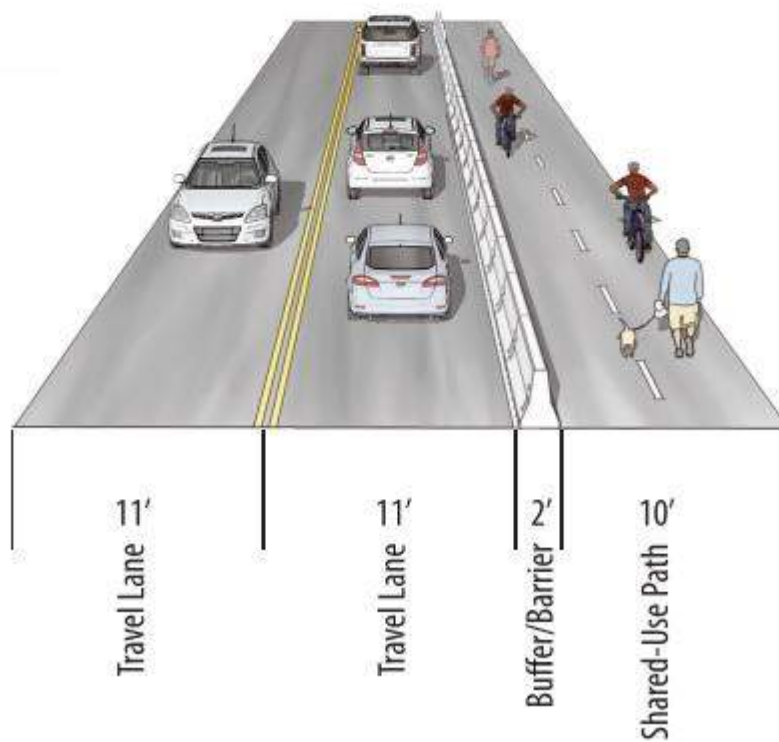

Figure 10. Crestview Cross section

## PAVING IMPROVEMENTS

Based on input from City staff, the Project Advisory Committee, and residents, there are several roadways within the community that have poor, or unsatisfactory pavement conditions. The City does not have a current Pavement Condition Index (PCI) analysis of its roads to document and prioritize roads from a technical analysis; therefore, this section is based solely on input from the community and observations. Paving roadways provides numerous benefits including dust/debris control, stormwater management, vehicle preservation and driver comfort. Several programs and projects are identified in Table 5 to improve the quality of roads in Oakridge.

One recommendation in Table 7 is a City street paving program. This recommendation would create a program to assess current conditions of roads through a PCI score, prioritize roads for improvement based on objective measures such as pavement conditions and frequency of use, and allocate a fixed funding stream to repair and maintain roads on a regular basis. Additional, specific, paving projects are listed in Table 7 and shown in Figure 11. These locations were identified for improvements based on public and city staff input, and paving projects carried forward from the 2000 TSP.

**Table 7. Proposed Paving Solutions**

Project ID	Project Name	Project Description	Location
PV-1	City street paving program	Develop a citywide program to assess and maintain City streets of all classification	Citywide
PV-2	Industrial Park Way	Pave Industrial Park Way from Mill Pond to Fish Hatchery Road	Industrial Park Way from Mill Pond to Fish Hatchery Road
PV-3	Osprey Park parking lot	Pave both the River Road and Perkins Street parking areas to access Osprey Park	Osprey Park (both River Road and Perkins Street parking areas)
PV-4	Berry Street	Repave Berry Street from Rainbow Street to the east	Berry Street from Rainbow Street to the east
PV-5	Jasper Drive	Repave Jasper Drive	Jasper Drive
PV-6	Paddock Lane	Pave Paddock Lane from W 2 <sup>nd</sup> Street to Union Street	Paddock Lane from W 2 <sup>nd</sup> Street to Union Street
PV-7	Beaver Lane/Beaver Street	Repave the extents of Beaver Lane/Beaver Street	The extents of Beaver Lane/Beaver Street
PV-8	Hansen Street	Repave Hansen Street from River Road to Klonn Road	Hansen Street from River Road to Klonn Road
PV-9	Cline Street	Repave Cline Street from Klonn Road to Garden Road	Cline Street from Klonn Road to Garden Road
PV-10	Portal Drive	Repave Portal Drive north of W 2 <sup>nd</sup> Street	Portal Drive north of W 2 <sup>nd</sup> Street
PV-11	Riverview Street	Repave Riverview Street from Klonn Road to Garden Road	Riverview Street from Klonn Road to Garden Road
PV-12	Jones Road	Repave Jones Road from OR 58 to Elgin Avenue	Jones Road from OR 58 to Elgin Avenue
PV-13	Elgin Avenue	Repave Elgin Avenue from Rock Road to the east	Elgin Avenue from Rock Road to the east
PV-14	Beech Street	Repave Beech Street north of E 1 <sup>st</sup> Street	Beech Street north of E 1 <sup>st</sup> Street
PV-15	Cherry Street	Repave Cherry Street north of E 1 <sup>st</sup> Street	Cherry Street north of E 1 <sup>st</sup> Street
PV-16	Douglas Street	Repave Douglas Street north of E 1 <sup>st</sup> Street	Douglas Street north of E 1 <sup>st</sup> Street
PV-17	Elm Street	Repave Elm Street north of E 1 <sup>st</sup> Street	Elm Street north of E 1 <sup>st</sup> Street



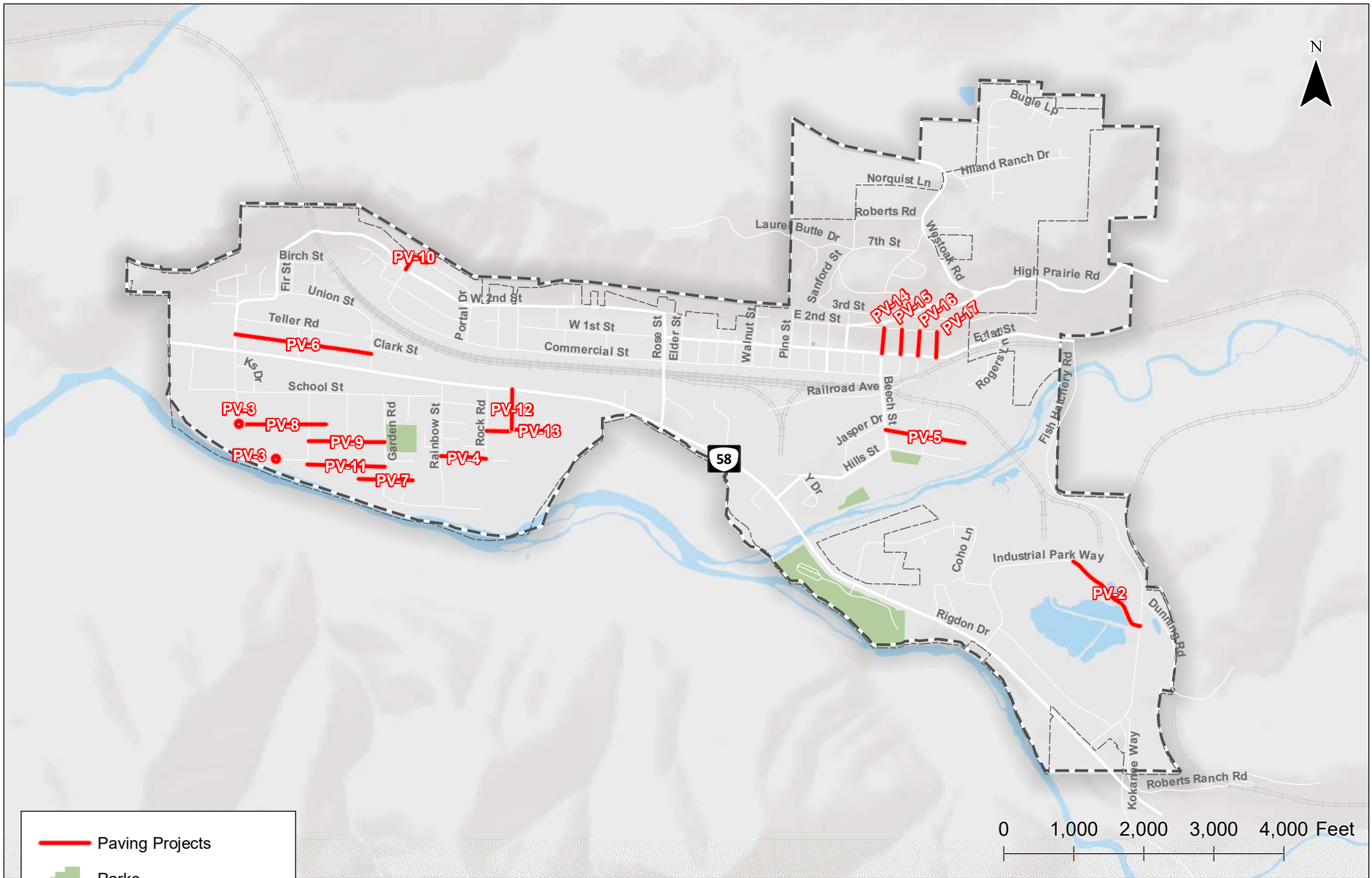

- Paving Projects
- + Parks
- Oakridge City Boundary
- Urban Growth Boundary

**Paving Projects  
Oakridge, Oregon**

**Figure  
11**

H:\22\22477 - Oakridge TSP Update\GIS\Memo 5 - Alternatives\10 Paving Projects.mxd - jgulczynski - 11:52 AM 6/21/2019

---

## SAFETY SOLUTIONS

---

The Transportation System Conditions, Deficiencies, and Needs Memorandum describes reported crash history in Oakridge between 2012 and 2016. It identified 42 reported crashes during the study period, including one fatality and three pedestrian/bicycle related crashes (all three resulting in injury).

In addition to crash data, discussion of near misses and perceived safety concerns offers valuable information on additional locations that should be evaluated for safety improvements. The Oakridge TSP Project Advisory Committee members described locations throughout Oakridge where they have experienced near-misses and locations with perceived safety risks. This feedback was documented in the Transportation System Conditions, Deficiencies, and Needs Memorandum.

Proposed solutions intended to improve safety outcomes and reduce crashes are shown in Table 8 and shown on the map in Figure 12. These locations were either supported by crash data or identified by members of the public as safety concerns. Additional information for each project is provided in the sections following the table and figure.

The first project (S-1) in the table refers to “systemic safety” intersection improvements. Systemic safety treatments are those that can be implemented on a large scale and are often integrated into a City’s procedures or standard roadway design guidelines. These treatments are focused on lower cost improvements with documented effectiveness at reducing crash potential. The systemic intersection treatments recommended as part of project S-1 are intended to enhance intersection visibility and awareness.

**Table 8. Proposed Safety Solutions**

Project ID	Project Name	Project Description	Location	Project Need
S-1	Systemic safety intersection improvements on OR 58	Provide/upgrade intersection warning signs, install or widen centerlines/edgelines, improve side street intersection visibility (signage, striping, recessed pavement markers).	Locations on OR 58 include, but are not limited to, Hills Street, Union Street, River Road, Rainbow Road, Hyland Lane.	Approximately 85% of the crashes that occurred on OR 58 in the study period occurred within 250 feet of an intersection. Improve intersection awareness on OR 58 and side streets
S-2*	Intersection safety improvement at High Prairie Road/West oak Road	Upgrade signing, sight distance improvements (including roadway realignment), curve warning and intersection warning	High Prairie Road/West oak Road Intersection	Poor sight distance, intersection visibility, and challenging intersection control
S-3	Intersection safety improvement at OR 58/Industrial Park Way	Move merge lane west approximately 400 feet and develop eastbound left turn lane into the industrial park. This project provides a dedicated eastbound left turn lane to eliminate existing conflicts with the end of the passing lane.	OR 58/Industrial Park Way Intersection	Current configuration lacks dedicated eastbound left turn lane into industrial park. In addition, the eastbound passing lane ends at this intersection, creating conflicts between vehicles stopped to turn left and those attempting to finish passing movements.
S-4	Intersection safety improvement at Crestview Street/E 1st Street	Reconfigure the intersection to slow vehicle speed through the intersection and reduce pedestrian exposure by installing a stop sign on the east leg to create an all-way stop-controlled intersection, installing a marked crosswalk on the east leg, removing the striped median and channelized northbound right turn to narrow south leg of the intersection.	Crestview Street/E 1st Street Intersection	The intersection is located on the most direct connection between the schools and OR 58. The uncontrolled movement between the east and south legs allows vehicles to travel through the intersection with stopping, and the channelized right-turn lane creates longer distance for pedestrians to cross, increasing exposure.
S-5	Speed feedback signs entering Oakridge (east and west)	Install speed feedback signs in conjunction with posted speed limit signs.	East and West approaches of OR 58 to Oakridge.	Vehicle traffic counts and speed data indicated vehicles are traveling over the posted speed on the highway.

\*Visionary Project

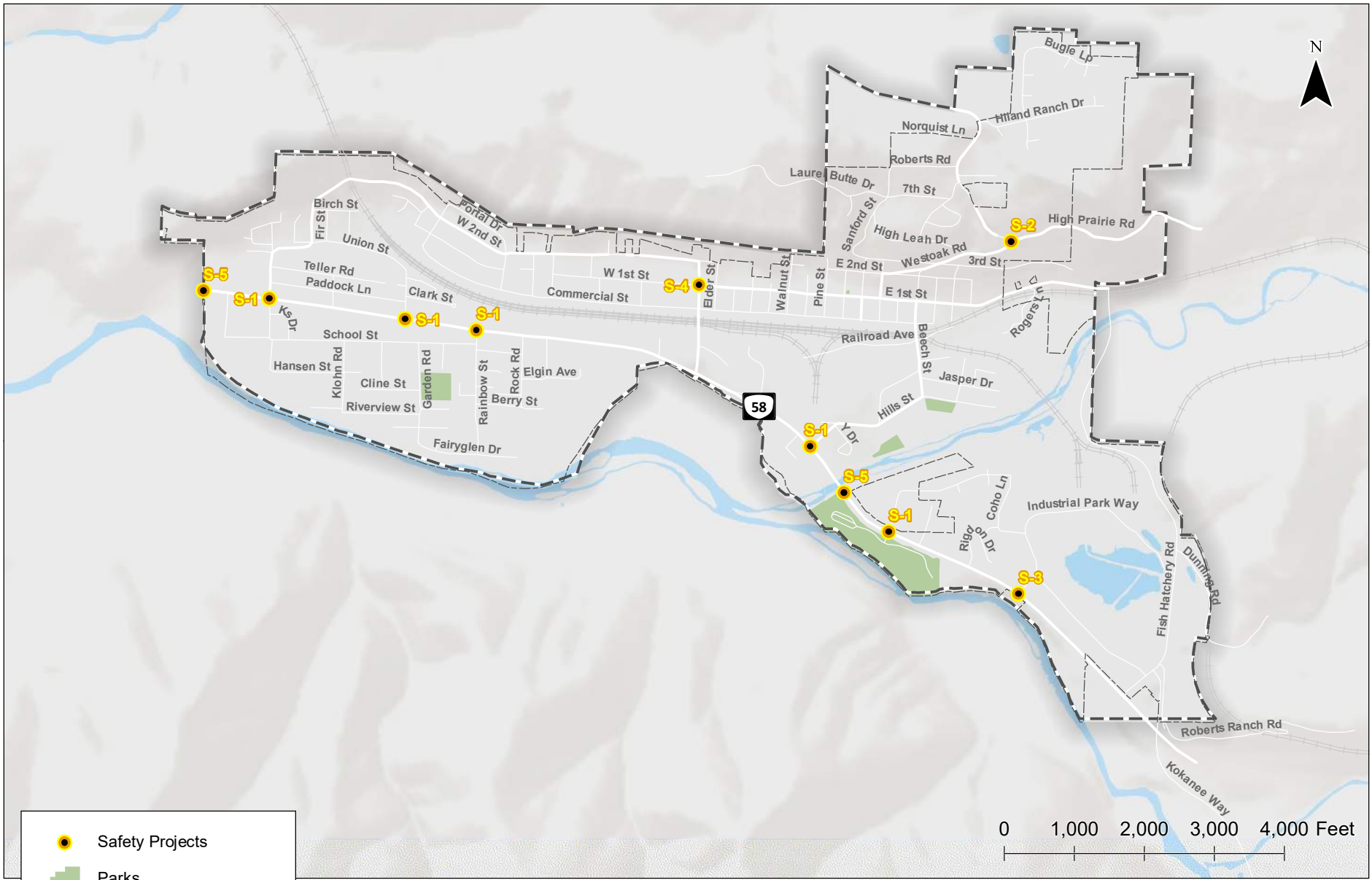

- Safety Projects
- Parks
- Oakridge City Boundary
- Urban Growth Boundary

**Safety Projects  
Oakridge, Oregon**

**Figure  
12**

H:\22\2477 - Oakridge TSP Update\GIS\Memo 5 - Alternatives\12 Safety Projects.mxd - igulczynski - 11:54 AM 6/21/2019

## Systemic Safety Intersection Improvements on OR 58 (S-1)

Approximately 85 percent of the crashes that occurred on OR 58 in the study period occurred within 250 feet of an intersection. Systemic intersection improvements on OR 58 such as intersection warning signs, installing or widening edgelines and/or centerline striping, and improving side street visibility can improve the overall safety of the intersections along the highway. Five locations along OR 58 are identified on the safety projects map for possible intersection improvements: Hills Street, Union Street, River Road, Rainbow Road, and Hyland Lane. However, these recommendations can be implemented citywide and incorporated in future projects. Additional information about systemic safety treatments for intersections can be found in ODOT's *Intersection Safety Implementation Plan* (2012).

## Intersection Safety Improvement at High Prairie Road/Westoak Road (S-2)

The intersection of Westoak Road/High Prairie Road is a skewed intersection that is currently stop controlled on the westbound approach of High Prairie Road to allow free flow on Westoak Road. Figure 13A shows an aerial, and Figure 13B shows a street view photo of the intersection. While this intersection does not have a reported crash history between 2012 and 2016, the intersection geometry, grade, sight distance, and nontraditional stop control have been identified as potential risk factors. It is currently unclear who has the right-of-way among the two eastbound approaches from Westoak Road. This intersection was placed on the visionary project list given the relatively low volumes and lack of reported crash history. Figure 14 shows a conceptual design of an intersection improvement at this location that adds additional stop signs and striping to clarify which driver has the right-of-way for each movement.



**Figure 13A. Aerial of the Westoak Road/High Prairie Road Intersection**



**Figure 13B Streetview of Westoak Road/High Prairie Road facing east from Westoak Road**

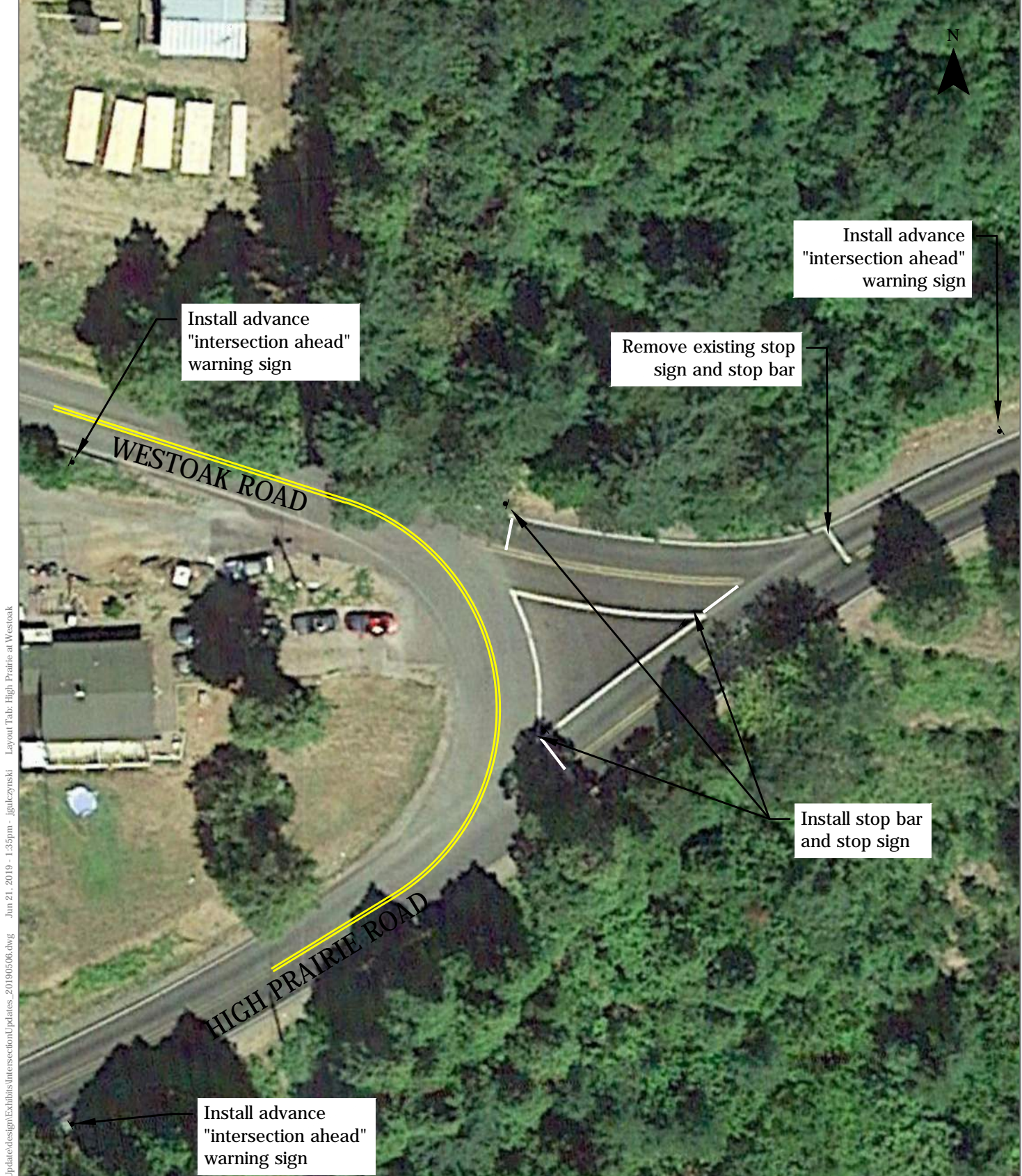

H:\22\22477 - Oakridge TSP Update\design\Exhibits\IntersectionUpdates\_20190606.dwg Jun 21, 2019 - 1:35pm - jguczyński Layout Tab: High Prairie at Westoak

Intersection Safety Improvement  
at High Prairie Road/Westoak Road  
Oakridge, Oregon

Figure  
14

## Intersection Safety Improvement at OR 58/Industrial Park Way (S-3)

The Industrial Park is located on the east side of Oakridge. This area serves several businesses and is identified by the City as an opportunity area for future commercial and industrial growth. The industrial park can be accessed by the highway at two locations: Industrial Park Way or Fish Hatchery Road. The existing OR 58/Industrial Park Way intersection has been identified by the community as a safety concern. Figure 15 shows an aerial of the intersection. The intersection is located at the end of the eastbound merge lane where many vehicles increase their speed while trying to complete a pass before the lane ends. A vehicle waiting to complete a left turn onto Industrial Park Way must wait in the left lane at the merge point. Drivers attempting to pass in the left lane are not expecting a stopped vehicle in the lane. Additionally, the intersection is located on the crest of a slight vertical curve. While there were no reported crashes at this intersection during the study period, it is identified as a safety concern.

A concept design was developed to improve the safety of the intersection. Figure 16 provides a dedicated eastbound left turn lane by restriping the highway and moving the eastbound left merge to the west, allowing space to develop a dedicated eastbound left-turn lane at Industrial Way, using existing pavement.



**Figure 15. Aerial of OR 58/Industrial Park Way Intersection**





H:\22\2477 - Oakridge TSP Update\design\Exhibits\intersections\updates\_20190506.dwg Jun 21, 2019 - 1:39pm - jguleczynski Layout Tab: OR58 at Industrial Park

OR58/Industrial Way  
Intersection Improvement Option A  
Oakridge, Oregon

Figure  
16

## Intersection Safety Improvement at Crestview Street/E 1st Street (S-4)

While there is no reported crash data at this intersection, the uncontrolled movement between the east and south legs allows vehicles to travel through the intersection without stopping, and the channelized right-turn lane creates longer distance for pedestrians to cross, increasing exposure. The intersection is located on the most direct connection between the schools and OR 58. Several design modifications could be made to reduce vehicle speeds and shorten pedestrian crossing distance to reduce pedestrian exposure.

Crestview Street ties into the intersection at a reasonable downgrade from the railroad bridge, and the schools are located to the northeast and northwest. As such, this intersection experiences a substantial amount of school traffic and pedestrian activity. Figure 17 provides a graphic illustrating the proposed updated geometry and intersection control. Improvements include converting the intersection to an all-way stop and removing the northbound channelized right turn. This would reduce speeds and reduce pedestrian exposure near the school zone. By providing a crossing on the east side of the intersection, this project ties in with the proposed shared-use path along the east side of Crestview Street (Project R-4).

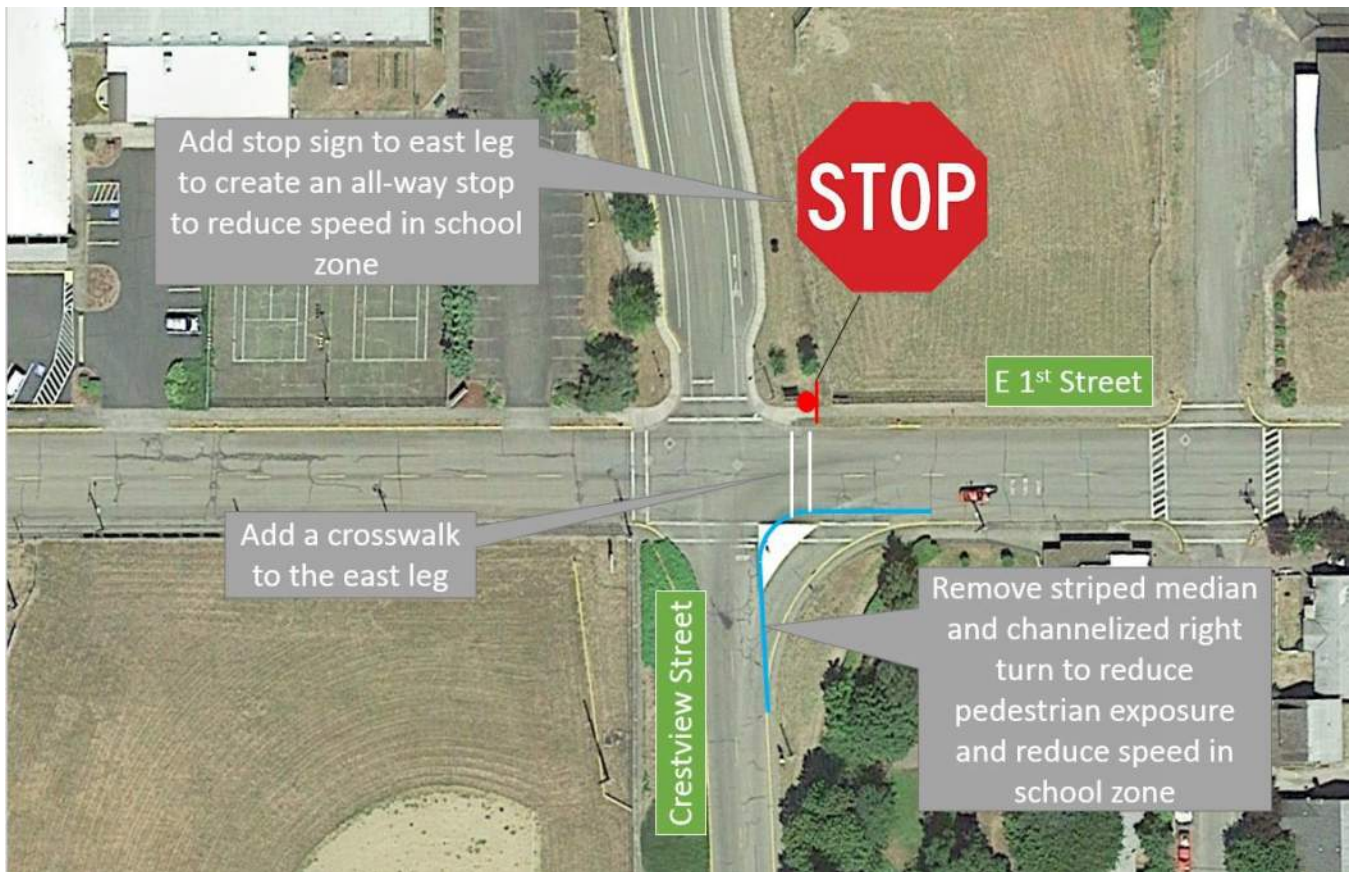

Figure 17. Intersection Improvement at Crestview Street/E 1st Street

## Speed Feedback Signs Entering Oakridge (S-5)

A speed feedback sign is a treatment designed to provide a message to drivers informing them of their speed relative to the posted speed limit. Figure 18 shows an example of a speed feedback sign. Speed feedback signs should be placed on the entering approaches on OR 58 into the City, where the speed drops to 35 mph and where the highway context visually changes from rural to more urban. The City would be required to coordinate with ODOT to approve and permit speed feedback signs within the ODOT right-of-way.



**Figure 18 .Example of Speed Feedback Sign**

## PEDESTRIAN SYSTEM SOLUTIONS

Pedestrian facilities within Oakridge are needed for recreational use and active transportation connections throughout the community and surrounding trail network.

As identified in the Transportation System Conditions, Deficiencies, and Needs Memorandum, there are substantial pedestrian needs throughout the community. The lack of sidewalks and shared-use paths on major roadways (i.e. arterials and collectors) creates a barrier for pedestrians. The proposed Pedestrian Plan is intended to create a connected system of facilities for pedestrians to travel throughout the City and to key destinations. Table 9 identifies proposed projects and the specific needs addressed. The plan includes proposed sidewalk, shared-use path, and crossing solutions. Figure 19 shows a map of the pedestrian projects.

**Table 9. Proposed Pedestrian Solutions**

Project ID*	Project Name	Project Description	Location	Project Need	Source
P-2	W 1st Street sidewalk	Fill in sidewalk gaps on both sides of W 1st Street	W 1 <sup>st</sup> Street between High Street and Poplar Street	Identified in roadway standards and there are several existing gaps in the sidewalk facilities	Identified Need
P-3	OR 58 sidewalks	Construct sidewalks (both sides) or a multiuse path on the highway	OR 58 from Thatcher Lane to Fish Hatchery Road.	There are substantial gaps to the sidewalk system on OR 58 west of Rock Road and no sidewalks east of Rock Road	Identified Need
P-4	River Road sidewalk	Construct sidewalk on west side of River Road	River Road from OR 58 to School Street.	Identified in roadway standards and there are no existing sidewalk facilities	Oakridge-Westfir Trails Plan 2008
P-5	W 2 <sup>nd</sup> Street sidewalk	Construct sidewalk on the west side of W 2 <sup>nd</sup> Street	W 2 <sup>nd</sup> Street from OR 58 to approximately 150 feet north of Teller Road.	Identified in roadway standards and there are no existing sidewalk facilities	Identified Need
P-6	W 2 <sup>nd</sup> Street sidewalk improvement	Widen existing sidewalk on northwest side of W 2 <sup>nd</sup> Street to provide at least 5 feet of continuous sidewalk*	W 2 <sup>nd</sup> Street from Teller Road to Commercial Street.	The existing sidewalk becomes very narrow in several locations along W 2 <sup>nd</sup> Street	Identified Need
P-7	W 2 <sup>nd</sup> Street sidewalk	Construct sidewalk on W 2 <sup>nd</sup> Street*	W 2 <sup>nd</sup> Street from Commercial Street to E Portal Drive.	Identified in roadway standards and there are no existing sidewalk facilities.	Identified Need
P-8	Local street sidewalk program	A citywide program to improve the local street sidewalk network throughout the City	Citywide	Lack of pedestrian facilities on local streets	Identified Need
P-9	Traffic Signal Pedestrian Improvement at Crestview/OR 58	Provide intersection lighting, pedestrian countdown timers for crossing of	OR 58/Crestview Street intersection	Potential vehicle/pedestrian conflicts associated with a traffic signal and the pedestrian traffic near the bus stop and other	2016 Safety Study

**Table 9. Proposed Pedestrian Solutions**

Project ID*	Project Name	Project Description	Location	Project Need	Source
		north leg, sidewalk infill on west side of north leg.		businesses. Existing crossing of OR 58 leads to a cliff; there is no shoulder or sidewalk on the south side of the highway.	
P-10	Sidewalk and Pedestrian Ramp Program	Develop program to assess condition and ADA compliance of existing sidewalks and pedestrian ramps.	Determined by study	The City lacks an inventory or program to assess existing sidewalks particularly those with close proximity to schools, school routes, areas with a pedestrian crash history, high traffic pedestrian routes	Identified Need
SU-1	Westoak Road Multiuse Path <sup>#</sup>	Construct a multiuse path on the north side of Westoak Road.	Westoak Road from Oak Street to the City limits.	There are limited multimodal options in the northeast area. This connection would provide connection to the Hiland Ranch residential area and should be coordinated with the County to ultimately create connections with Westfir.	Oakridge-Westfir Trails Plan 2008
SU-2	Fish Hatchery Road Multiuse Path	Construct a multiuse path along Fish Hatchery Road. This project should include a transition from a shared-use path back to sidewalks/ bicycle lanes on E 1 <sup>st</sup> Street.	Fish Hatchery Road from OR 58 to the existing sidewalk on E 1 <sup>st</sup> Street.	There are limited multimodal options on the east side of the City.	Identified Need
SU-3	Industrial Park Way Multiuse Path	Construct a multiuse path on the north side of Industrial Park Way	Industrial Park Way from OR 58 to Fish Hatchery Road	There are limited multimodal options in the industrial park. Cross section requires multimodal accommodations.	Identified Need
SU-4	High Prairie Road Multiuse Path	Construct a multiuse path on the north side of High Prairie Road	High Prairie Road from Westoak Road to City limits.	There are limited multimodal options in the northeast area. Cross section requires multimodal accommodations.	Identified Need
SU-5	Garden Road, Fairyglen Drive, Rainbow Street Multiuse Path	Construct a multiuse on Garden Road, Fairyglen Drive, Rainbow Street	South of the Willamette Activity Center on Garden Road to Fairyglen Drive and Rainbow Street to the sidewalk connection	Bicycle and pedestrian connectivity on the local street network south of OR 58	Identified Need

**Table 9. Proposed Pedestrian Solutions**

Project ID*	Project Name	Project Description	Location	Project Need	Source
SU-6	Salmon Creek Trail Bridge	Construct a bridge crossing between the parallel Salmon Creek trails.	Across the Salmon Creek near OR 58.	There are no river crossings for pedestrians and cyclists on the Salmon Creek Trail. The current OR 58 bridge does not have sidewalks.	2000 TSP
SU-7	West Oakridge Trail Bridge Feasibility Study	Construct a bridge crossing from Osprey Park south of the Willamette River and connect to the existing trail system	Across the Willamette River near Osprey Park	There are no river crossings for pedestrians and cyclists south of Greenwaters Park.	Identified Need
SU-8	Union Street Multiuse Path	Construct a multiuse path on the north/east side of Union Street	Union Street from OR 58 to W 2 <sup>nd</sup> Street	Frequently used bicycle and pedestrian route on a local street	Identified Need
C-1	Marked Pedestrian Crossings	Install marked crosswalks on arterials and collectors where sidewalks are present to provide a complete pedestrian network	See Figure 18 for locations.	Lack of marked crosswalks at major intersections; priority should be placed with locations that are located near schools or on routes to schools, locations that facilitate the transition of sidewalks from one side of the road to another, and locations of transitions between facility types.	Identified Need
C-2	Feasibility study for grade separated railroad overcrossing/undercrossing at Union Street and Commercial Street	Evaluate the feasibility of building a grade-separated crossing of the railroad tracks. The design should include ways to make the crossing desirable for pedestrians and bicyclists, minimize out of direction travel, and discourage at-grade crossing of the railroad.	Railroad crossing between Union Street and Commercial Street approximately a quarter-mile east of W 2 <sup>nd</sup> Street.	This crossing of the railroad is on one of the most direct paths between the school and western end of OR 58 and the residential areas in the southwest area of the City. The lack of sidewalks on OR 58, east of Rock Road means that there is no alternative route for pedestrians to cross both the highway and railroad without substantial out of direction travel and grade on W 2 <sup>nd</sup> Street.	Identified Need
C-3	Beech Street rail crossing improvements	Install pedestrian and cyclist at grade railroad crossing	Beech Street rail crossing.	Currently the at grade crossing does not have a multimodal crossing	Identified Need
C-4	OR 58/River Road-Thatcher Lane Pedestrian Safety Improvement	Install enhanced pedestrian crossing which could include raised median, curb extension, traffic calming, illumination, etc.	On OR 58, approximately 350 feet east of Thatcher Lane.	Identified to address crash history, proximity to pedestrian generators, and distance to nearest marked crossing	2016 Safety Study

**Table 9. Proposed Pedestrian Solutions**

Project ID*	Project Name	Project Description	Location	Project Need	Source
C-5	OR 58/Rainbow Road Pedestrian Safety Improvement	Install enhanced pedestrian crossing which could include raised median, curb extension, traffic calming, illumination, etc.	On OR 58, approximately 40 feet east of Rainbow Road.	Identified to address crash history and proximity to pedestrian generators	2016 Safety Study
C-6	OR 58/Hill Street Pedestrian Safety Improvement	Install enhanced pedestrian crossing which could include raised median, curb extension, traffic calming, illumination, etc.	On OR 58, approximately 20 feet east of Hills Street.	Project developed in 2016 Pedestrian Safety Study to address: Proximity to pedestrian generators (including a bus stop) and distance to nearest marked crossing	2016 Safety Study
C-7	OR 58/Union Street Pedestrian Safety Improvement	Install enhanced pedestrian crossing which could include raised median, curb extension, traffic calming, illumination, etc.	On OR 58, approximately 20 feet east of Union Street.	Identified to address school related pedestrian crossings, proximity to pedestrian generators	2016 Safety Study

\*P-1 removed based on comments received by the PAC. Projects will be renumbered as part of the TSP

#Consistent with the options shown in the typical street sections, some projects recommend sidewalk on only one side of the road, or a shared-use path in place of sidewalks.

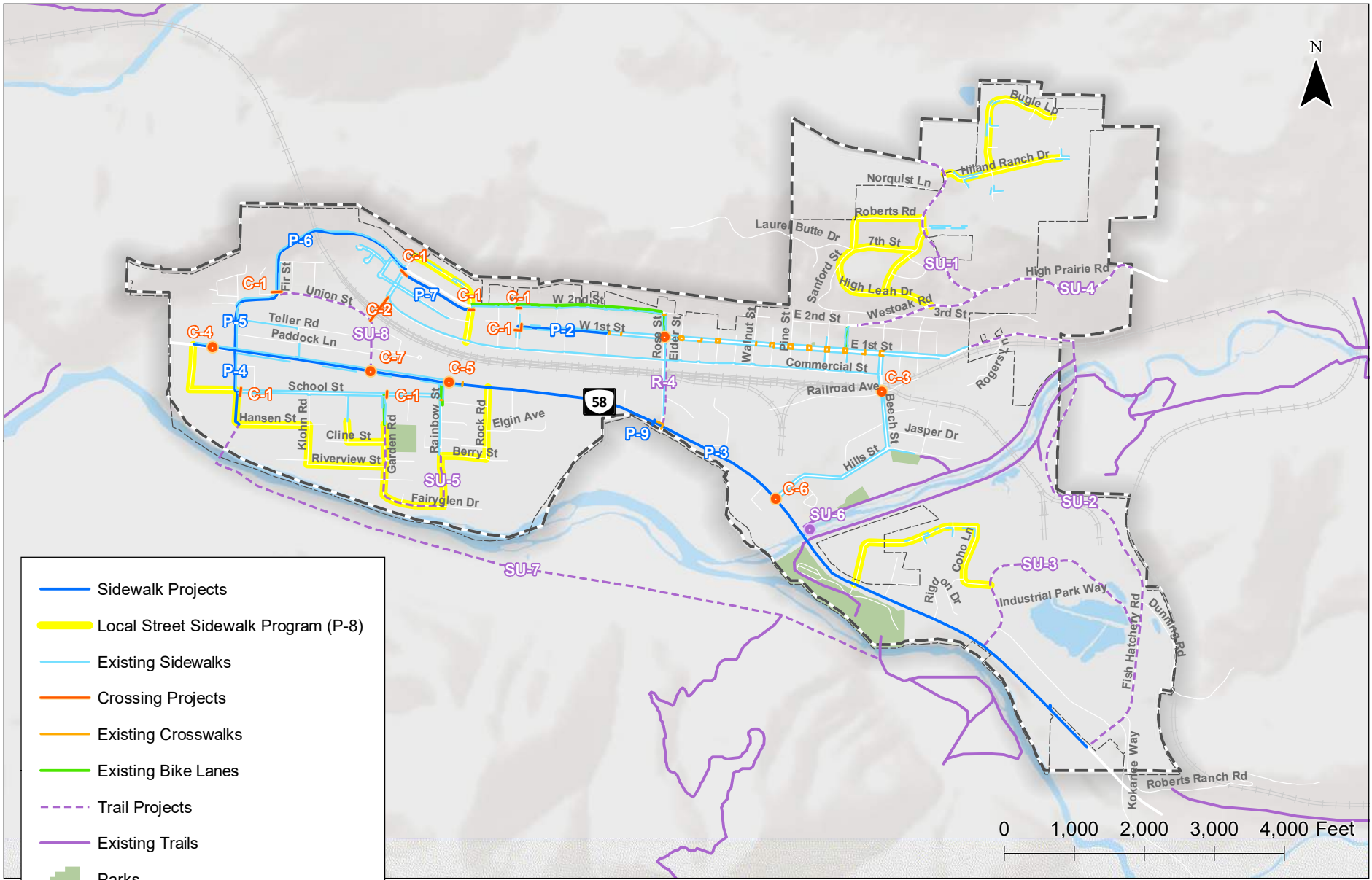

**Pedestrian Projects  
Oakridge, Oregon**

**Figure  
19**

H:\22\2477 - Oakridge TSP Update\GIS\Memo 5 - Alternatives\19 Pedestrian Projects.mxd - jguczynski - 4:09 PM 7/11/2019



## BICYCLE SYSTEM SOLUTIONS

Similar to the pedestrian system, there are a lack of connected bicycle facilities throughout the City. Bicycle infrastructure standards for Oakridge are shown in Table 2: *Typical Cross section Standards*. According to the standards, all arterials and collectors should include dedicated bicycle facilities. In some situations, a shared-use path may be appropriate to serve as a substitute for dedicated bicycle lanes. However, the unique context of each location should be considered before making this decision. Locations with many driveways, for example, may not be ideal locations for accommodating two-way bicycle traffic on a shared-use path. In addition, the transition between a shared-use path and sidewalks and/or bicycle lanes should be designed appropriately during project development.

The TSP considered the projects and improvements identified in the Oakridge-Westfir Community Trails Plan as part of the pedestrian and bicycle system. The following projects were carried forward and are included as key projects for the TSP including multimodal improvements on OR 58, Commercial Street, Beech Street, Industrial Park Way, Fish Hatchery Road, Westoak Road, and W 2<sup>nd</sup> Street.

The existing bicycle infrastructure includes several segmented bicycle facilities and lacks complete east-west and north-south connectivity. To improve the Citywide bicycle network, dedicated bicycle facilities should be installed on all major roadways including W 2<sup>nd</sup> Street E 1<sup>st</sup> Street, Hills Street, and School Street. Additionally, providing a complete network on major roadways to the schools is critical to providing direct access for students. Table 10 identifies a list of the proposed projects and needs associated with the bicycle system in Oakridge. Figure 20 presents a map of proposed project locations.

**Table 10. Proposed Bicycle Solutions**

Project ID	Project Name	Project Description	Location	Project Need	Source
B-1	W 2nd Street bicycle lanes	Install bicycle lanes on W 2nd Street	W 2 <sup>nd</sup> Street from OR 58 to E Portal Drive.	Create bicycle network on major roadways	Identified Need
B-2	Commercial Street bicycle lanes	Install bicycle lanes on Commercial Street	Commercial Street from W 2nd Street to Beech Street.	Create bicycle network on major roadways	Identified Need
B-3	E 1 <sup>st</sup> Street bicycle lanes	Install bicycle lanes on E 1 <sup>st</sup> Street	Poplar Street to City Limits.	Create bicycle network on major roadways	Identified Need
B-4	Hills Street/Beech Street bicycle lanes	Install bicycle lanes on Hills Street/Beech Street	Hill Street/Beech Street from OR 58 to E 1st Street.	Create bicycle network on major roadways	Identified Need
B-5	School Street and Rivers Road bicycle lanes	Install Bicycle lanes on School Street and Rivers Road	Rivers Road: OR 58 to School Street; School Street: Rivers Road to Rainbow Road.	Create bicycle network on major roadways	Identified Need
B-6	OR 58 bicycle lanes	Install bicycle lanes along OR 58	OR 58 from Thatcher Lane to Fish Hatchery Road.	OR 58 is the primary east-west connection through the City but lacks bicycle lanes and continuous sidewalk. Strava data shows riders use this route. With relatively high traffic volume and speed, a dedicated facility is needed.	Identified Need

**Table 10. Proposed Bicycle Solutions**

Project ID	Project Name	Project Description	Location	Project Need	Source
B-7	Bicycle support hub	Construct a bicycle hub, or "rest stop," for hikers, bicyclists, recreationalists, and community members; provide small shelter, information kiosk (map/community calendar), bicycle tool station, lockers, showers, and/or bench/sitting area.	This should be coordinated with potential sponsors for cost purposes and with partnering agencies to identify the best location.	A large number of recreational riders visit Oakridge; these riders do not have a dedicate location for information, repair, and rest.	Identified Need
B-8	Citywide bicycle signage program	Provide bicycle signage throughout the community directing cyclists to the Citywide bicycle network and to nearby trails.	Throughout the community on key bicycle routes.	Wayfinding for commuter and recreational cyclists	Identified Need
B-9	Trail connection study	Complete study to identify bike facility connections to trail network	Determined by study	Provide connections between City and trail system	Identified Need

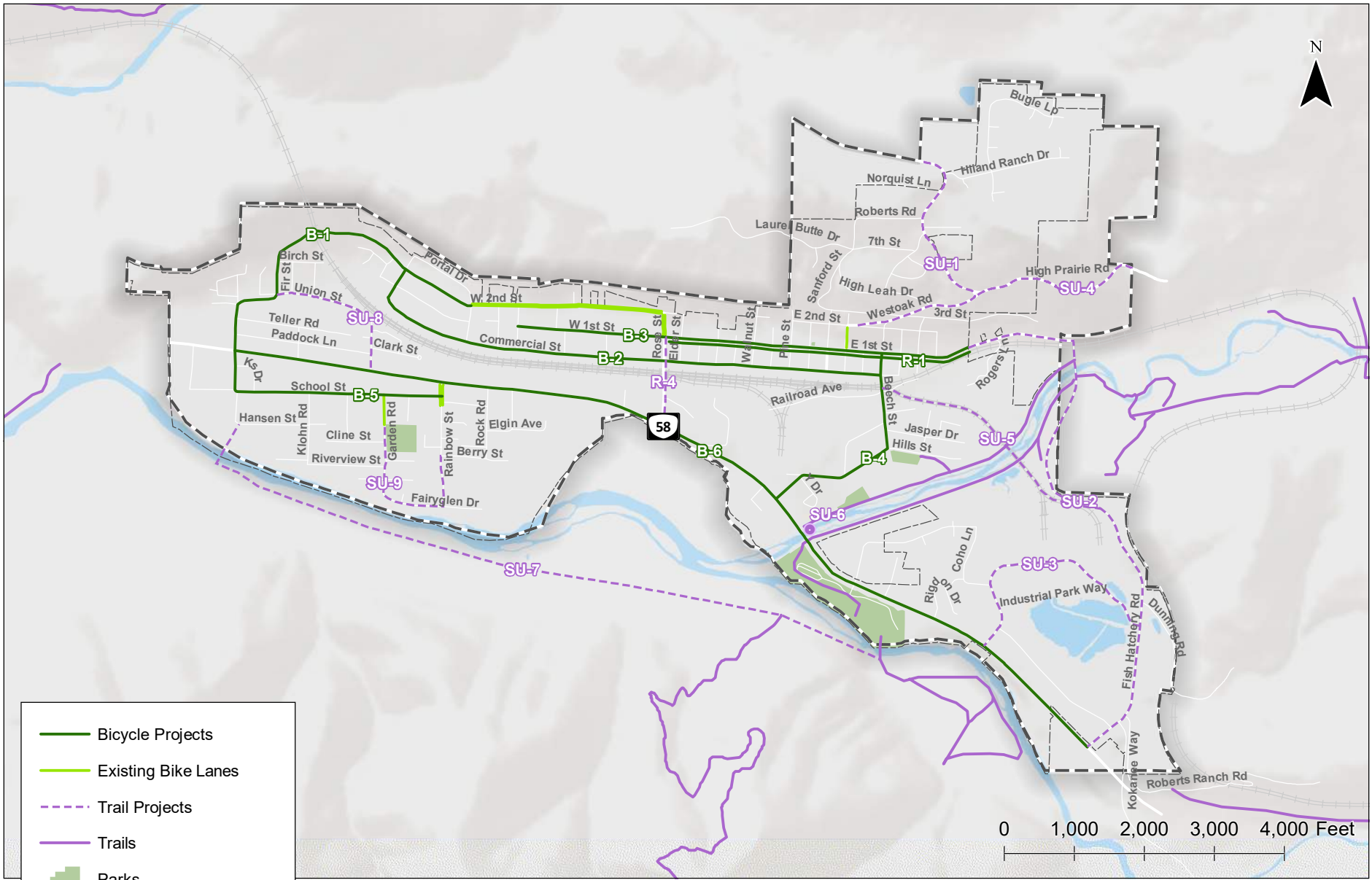

- Bicycle Projects
- - - Existing Bike Lanes
- - - Trail Projects
- Trails
- Parks
- Oakridge City Boundary
- Urban Growth Boundary

**Bicycle Projects  
Oakridge, Oregon**

**Figure  
20**

H:\2202477 - Oakridge TSP Update\gis\Memo 5 - Alternatives\19 Bicycle Projects.mxd - 1:15 PM 6/21/2019

---

## TRANSIT SYSTEM SOLUTIONS

---

As described in the Transportation System Conditions, Deficiencies, and Needs Memorandum, the Lane Transit District (LTD) provides public transportation to Oakridge via a fixed route call the "Diamond Express". The Diamond Express provides service from Eugene to the cities of Oakridge and Westfir. This service includes three round trips per weekday. There is no service available on the weekends.

There are currently no community-wide Dial-A-Ride services available. Dial-A-Ride is a common transit service that provide curb-to-curb, shared transit services to the disabled and senior community. A private, volunteer dial-a-ride service is currently provided through the Senior and Disability Services Division. In addition, Pacific Crest Bus Lines, who operates the Diamond Express under a contract through LTD, provides demand-response transportation within Oakridge two days per week. This service transports seniors to meals at the Senior Center on Tuesdays and Thursdays. Providing a regular public service for the transportation disadvantaged improves the livability and sustainability of a community and is therefore included in the transit alternatives. This service should extend beyond the two-day service for meals and provide an opportunity for residents to travel for medical appointments, shopping, and social activities.

Rural communities, like Oakridge, often provide challenges for transit providers due to lower population numbers. Overall, Oakridge has a relatively low population density; however, the Diamond Express provides an alternative mode to get to and from Eugene. Approximately 36 percent of Oakridge residents live below the poverty line and 38 percent identify a having some level of disability<sup>4</sup>. Providing opportunities for disadvantaged populations to traverse around the community is critical to the livability and sustainability of the city.

Table 11 identifies the proposed transit solutions in Oakridge. These needs were also identified by the Community Transportation Association of America (CTAA) technical assistance meetings, conducted in the Fall of 2018. The meeting notes from the CTAA meetings are provided in Appendix B.

Figure 21 provides a map of the existing transit routes and current stops, along with two proposed transit stops (T-3). These locations were identified based on proximity to trip generators and connectivity to the existing transit route, in order to have minimal impact to the existing schedules. A feasibility study should be completed with support from LTD and the City to identify additional transit needs such as increased service, seasonal amenities for peak recreation periods, and service upgrades.

---





<sup>4</sup> REPRESENTED IN FIGURES 11 AND 12 IN TECHNICAL MEMORANDUM #4: TRANSPORTATION SYSTEM CONDITIONS, DEFICIENCIES, AND NEEDS

**Table 11. Transit Solutions**

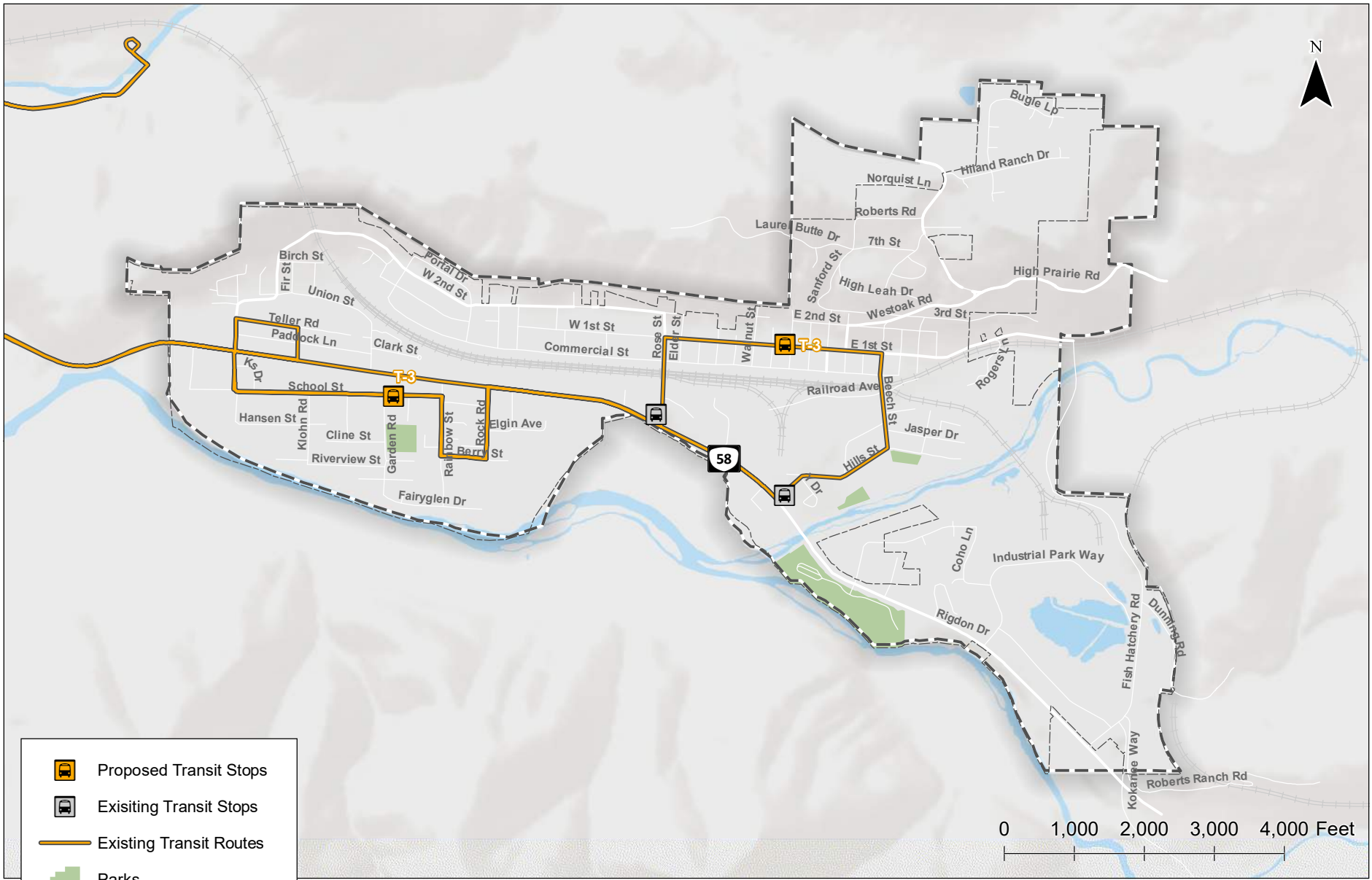
Project ID	Project Name	Project Description	Location	Project Need
T-1	Community Dial-A-Ride	Provide accessibility for residents, particularly seniors and those with disabilities, through a dial-a-ride service that operates seven-days per week.	Community-wide	Oakridge does not have a formal service for the transportation disadvantaged who have personal (medical, shopping, etc.) travel needs
T-2	Feasibility study for fixed route service within Oakridge	Conduct a feasibility study to evaluate the ability to provide fixed route service (operating five-days per week) within Oakridge. This service may be a fixed route service, or a forma dial-a-ride service (T-1). Based on the outcome of the study, increase frequency (number of routes per day), service days (consider a pilot project providing weekend transit service), and length of service in Oakridge to provide stops at more destinations.	Determined by study	Oakridge does not have fixed route service within the community
T-3*	Feasibility study to improve existing Diamond Express LTD route	Conduct a transit feasibility study with support from LTD and the City to determine whether service frequency (number of routes per day and number of days per week) and number of stops within Oakridge can be increased; and whether the service can better accommodate bicycles and can be better coordinated with LTD. Consider a near-term pilot program of limited Diamond Express operations on weekends.	Shown in Figure 20	The existing network serves a limited area of the community due to the location of bus stops. In addition, the Oakridge is not part of the LTD; riders of the Diamond Express must therefore pay again if transferring to a bus in Eugene.
T-4	Transit community outreach	Educate the community about connections available within Oakridge to reach key destinations such as Eugene and Springfield.	Community-wide	Increase ridership by educating community on transit opportunities

\*Visionary Project



-  Proposed Transit Stops
-  Existing Transit Stops
-  Existing Transit Routes
-  Parks
-  Oakridge City Boundary
-  Urban Growth Boundary

**Transit Projects  
Oakridge, Oregon**

**Figure  
21**

H:\22\2477 - Oakridge TSP Update\GIS\Memo 5 - Alternatives\20 Transit Projects.mxd - igulczynski - 1:17 PM 6/21/2019

## RAIL AND AIR SYSTEM SOLUTIONS

The rail line that travels through Oakridge are owned and operated by Union Pacific. The railroad creates a barrier for north-south travel within the City. The railroad also presents a potential opportunity for freight and/or passenger service for Oakridge. There are two public crossings in city limits: one grade separated crossing at Crestview Street and one at-grade crossing at Beech Street. There is also a private at-grade crossing at Rogers Lane and an at-grade crossing just east of city limits on the County-owned Fish Hatchery Road.





The Oakridge Airport is located outside of the city limits. However, it is an important economic development component to the City. The City should consider adopting an airport policy to continue to support the airport.

Table 12 presents the proposed rail and air solutions developed through this TSP update to address identified needs. Figure 22 provides a map of solutions associated with railroad. Several of the recommended solutions require additional analysis and coordination with Union Pacific and ODOT Rail prior to advancing the concept. Feasibility studies should be completed for implementation of structures along the rail line (RL-2) and potential for a passenger rail stop in Oakridge (RL-3). Coordination with Union Pacific will be required before the implementation of any alternative.

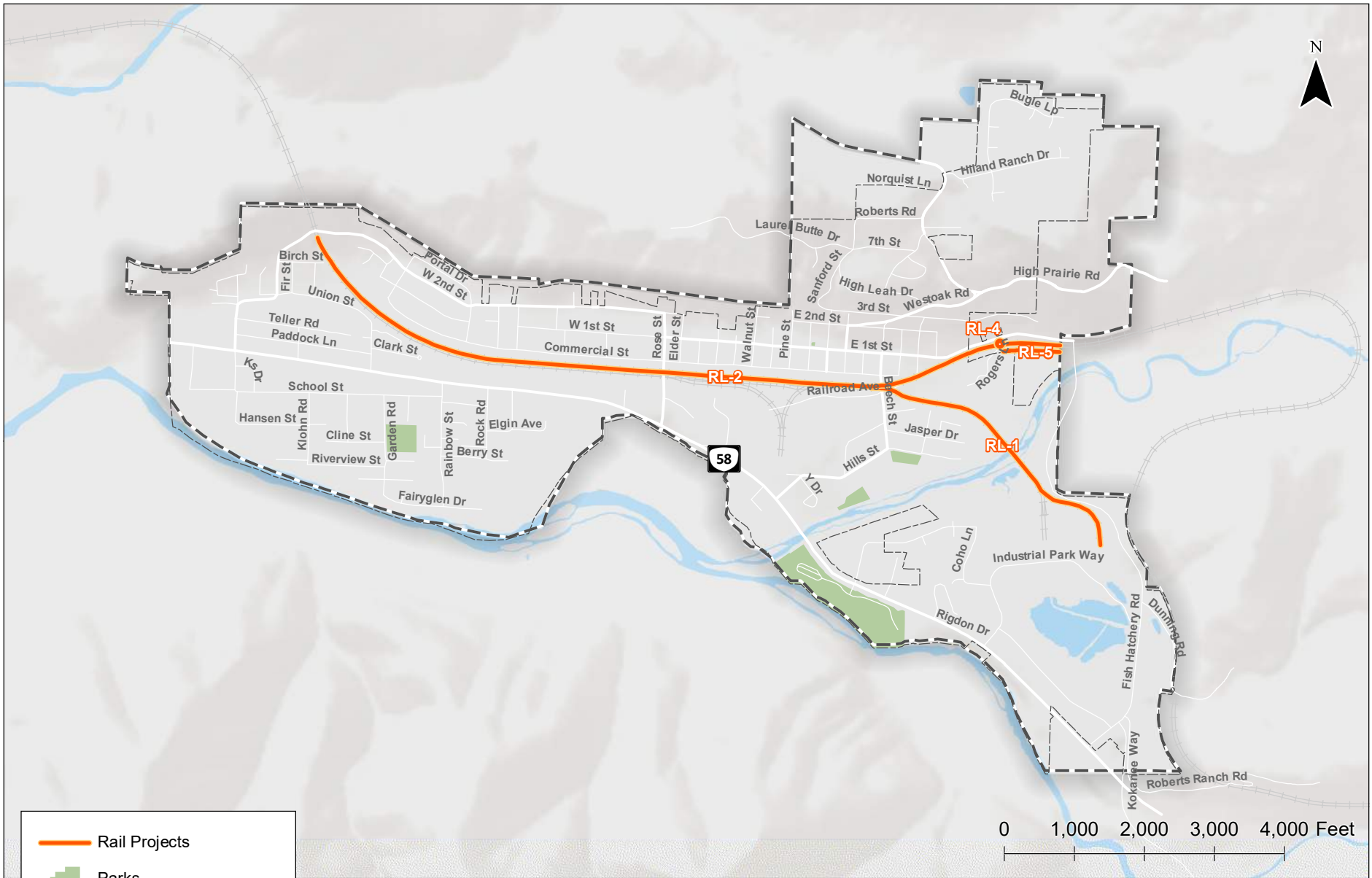
Project ID	Project Name	Project Description	Location	Project Need
RL-1	Industrial Park Rail Spur Feasibility Study	Conduct a study to determine a viable future use of the existing railroad spur located in the Industrial Park. Options include maintaining the spur for future industrial park use or converting to a shared-use path through a rails to trail project.	Railroad, between the industrial park and Beech Street.	Preserve the ability for the City to determine an appropriate use of the existing spur.
RL-2	Conduct a quiet zone feasibility study	Conduct a quiet zone feasibility study for the railroad to identify measures to reduce noise.	Along the railroad within City limits.	There are no sound barriers between the rail line and residents. Noises made by trains may be disruptive to community, particularly during non-peak or nighttime hours.
RL-3	Conduct an Amtrak passenger rail study	Conduct a feasibility study to identify the demand, desire, and funding needed to provide an Amtrak passenger rail stop in Oakridge	Along the railroad within City limits.	Oakridge citizens have expressed interest in an Amtrak passenger stop in town; it would also support tourism.
RL-4	Rogers Lane crossing upgrade	Upgrade Rogers Lane to a public crossing. This will require coordination with Union Pacific.	At-grade railroad crossing at Rogers Lane.	The crossing provides access to developable land south of Rogers Lane
RL-5	Swank Lane roadway upgrade	Construct Swank Lane as an alternative route to land between the rail line and Salmon Creek	Swank Lane west of Fish Hatchery Road	The roadway provides a route to the parcel west of Fish Hatchery Road
A-1	Protect and maintain the Oakridge State Airport	Adopt a policy to preserve and maintain the Oakridge State Airport	Oakridge State Airport.	Preserve the functionality of a regional airport in Oakridge

\*All projects related to the rail line will require additional coordination with Union Pacific and ODOT Rail prior to implementation



-  Rail Projects
-  Parks
-  Oakridge City Boundary
-  Urban Growth Boundary

**Rail Projects  
Oakridge, Oregon**

**Figure  
22**

H:\22\2477 - Oakridge TSP Update\GIS\Memo 5 - Alternatives\21 Rail Projects.mxd - igulczynski - 1:18 PM 6/21/2019



## OR 58 SOLUTIONS

The OR 58 corridor is an important east-west corridor within the City of Oakridge. It provides regional connections throughout the state as a statewide freight corridor, but also accommodates many local businesses and provides direct access to numerous parcels. The highway moves traffic through the community but also creates a barrier that north-south traffic of all modes must access and/or cross. The system conditions and future needs analysis identified issues and concerns related to speeding and safety along the corridor as well as excess capacity. There is currently a lack of continuous pedestrian and bicycle facilities throughout the corridor.

Table 13 provides a summary of the proposed solutions identified in previous sections of this report that pertain to OR 58. As shown, there are several vehicle related projects and a high number of active transportation projects on the highway, including sidewalk infill, bicycle lanes, and multimodal crossing locations.

One solution proposed is a street reconfiguration of OR 58 within the City limits. This would include reducing the number of travel lanes to accommodate a complete street cross section with dedicated bicycle lanes and sidewalks. The street reconfiguration alternative is described in more detail below and was shown to operate acceptably. The TSP recommends implementation of a pilot project to evaluation how the community responds to the street reconfiguration in a small section of town for a limited duration, while conducting a feasibility study to determine how the complete cross section could be implemented throughout the entire corridor.

**Table 13. Proposed OR 58 Solutions**

Project ID	Project Name	Project Description	Location	Project Need
R-5	OR 58 Illumination	Provide illumination along the highway within City limits	OR 58 from River Road to Hills Street	Lack of segment lighting along the highway leads to higher speeds and difficulty identify pedestrians and bicyclists during nighttime conditions
R-6	OR 58 Street Reconfiguration Pilot Project	Implement a temporary lane reconfiguration on OR 58. The pilot project would serve as a public demonstration of a potential future highway reconfiguration that is low cost and can be removed or later fully implemented, depending upon success of the pilot project.	OR 58 from Thatcher Lane to Jones Road	Concern of traffic speeds and safety.
R-7*	Long Term OR 58 Street Reconfiguration	Reconfigure the highway's cross section to accommodate one lane in each direction with multimodal facilities, based on results of pilot project. Potential benefits of a lane configuration include decreased conflict points, improved access, improved pedestrian and bicycle mobility.	Determined by study	Concern of safety for all modes and traffic speeds.
S-1	OR 58 Systemic Safety Intersection Improvements	Provide/upgrade intersection warning signs, install or widen centerlines/edgelines, improve side street intersection visibility (signage, striping, recessed	Intersections along OR 58 include, but are not limited to, Hills Street, Union	Approximately 85% of the crashes that occurred on OR 58 in the study period occurred within 250 feet of an intersection. Improve

**Table 13. Proposed OR 58 Solutions**

Project ID	Project Name	Project Description	Location	Project Need
		pavement markers). Locations include, but are not limited to, Hills Street, Union Street, River Road, Rainbow Road, Hyland Lane.	Street, River Road, Rainbow Road, Hyland Lane.	intersection awareness on OR 58 and side streets
S-3	OR 58/Industrial Park Way Intersection Safety Improvement	Move merge lane west approximately 400 feet and develop eastbound left turn lane into the industrial park. This project provides a dedicated eastbound turn lane to eliminate conflicts with the end of the passing lane.	OR 58/Industrial Park Way Intersection	Current configuration lacks dedicated eastbound left turn lane into industrial park. In addition, the eastbound passing lane ends at this intersection, creating conflicts between vehicles stopped to turn left and those attempting to finish passing movements.
S-5	Gateway speed feedback signs (east and west)	Install speed feedback signs in conjunction with posted speed limit signs on the east and west approaches of OR 58 to Oakridge	East and West approaches of OR 58 to Oakridge.	Vehicle traffic counts and speed data indicated vehicles are traveling over the posted speed on the highway.
P-3	OR 58 sidewalks	Construct sidewalks (both sides) or a multiuse path on the highway	OR 58 from Thatcher Lane to Fish Hatchery Road.	There are substantial gaps to the sidewalk system on OR 58 west of Rock Road and no sidewalks east of Rock Road
P-9	Crestview/OR 58 Traffic Signal Pedestrian Improvement	Provide intersection lighting, pedestrian countdown timers, sidewalk infill on west side of north leg	OR 58/Crestview Street intersection	Vehicle/pedestrian conflicts associated with a traffic signal and the pedestrian traffic near the bus stop and other businesses
B-6	OR 58 bicycle lanes	Install bicycle lanes along OR 58	OR 58 from Thatcher Lane to Fish Hatchery Road.	OR 58 is the primary east-west connection through the City but lacks bicycle lanes and continuous sidewalk. Strava data shows riders use this route. With relatively high traffic volume and speed, a dedicated facility is needed.
C-4	OR 58/River Road-Thatcher Lane Pedestrian Safety Improvement	Install enhanced pedestrian crossing which could include raised median, curb extension, traffic calming, illumination, etc.	On OR 58, approximately 350 feet east of Thatcher Lane.	Project developed in 2016 Pedestrian Safety Study to address: Crash history, proximity to pedestrian generators, and distance to nearest marked crossing
C-5	OR 58/Rainbow Road Pedestrian Safety Improvement	Install enhanced pedestrian crossing which could include raised median, curb extension, traffic calming, illumination, etc.	On OR 58, approximately 40 feet east of Rainbow Road	Project developed in 2016 Pedestrian Safety Study to address: Crash history and proximity to pedestrian generators,

**Table 13. Proposed OR 58 Solutions**

Project ID	Project Name	Project Description	Location	Project Need
C-6	OR 58/Hill Street Pedestrian Safety Improvement	Install enhanced pedestrian crossing which could include raised median, curb extension, traffic calming, illumination, etc.	On OR 58, approximately 20 feet east of Hills Street	Project developed in 2016 Pedestrian Safety Study to address: Proximity to pedestrian generators (including a bus stop) and distance to nearest marked crossing
C-7	OR 58/Union Street Pedestrian Safety Improvement	Install enhanced pedestrian crossing which could include raised median, curb extension, traffic calming, illumination, etc.	On OR 58, approximately 20 feet east of Union Street	Project developed in 2016 Pedestrian Safety Study to address: School related pedestrian crossings, proximity to pedestrian generators

\*Visionary Project

## OR 58 Street Reconfiguration

This section describes the street reconfiguration project and the benefits it may have for the community and region. A street reconfiguration on OR 58 would include a reduction of travel lanes from either five lanes to three lanes or four lanes to three lanes. A street reconfiguration often includes converting excess pavement to bicycle lanes, parking, and/or pedestrian facilities.

Figure 23 shows an example of a recent street reconfiguration on OR 99-North Main Street in Ashland, Oregon. As shown, a four-lane section was reduced to a single through lane in each direction with a center turn lane and bicycle lanes. Ashland is located approximately 10 miles south of Medford and has a population of roughly 21,000. Ashland has two primary highways within the town including I-5 and OR 99. While I-5 acts primarily as a bypass east of the City, OR 99 is the primary, high volume route for the City. Current ODOT traffic data identified approximately 16,000 vehicles that use OR 99 every day – nearly double the existing volumes on OR 58. With higher volumes and a larger population, the City of Ashland adopted a street reconfiguration after conducting a successful pilot project.



**Figure 23. Example of Street reconfiguration in Ashland, OR (left: before, right, after)**

Street reconfiguration projects are proven to provide several benefits including:

- Improved traffic flow

- Eliminates lane changes and weaving maneuvers
- ▶ Reduced vehicle speeds
  - Reduces speeds by creating a "tunnel effect" and narrowing of the vehicular travel way
- ▶ Reduced number of crashes
  - Removes conflict points from the second travel lane that may lead to severe and fatal crashes. These include turning movement and angle crashes
  - Slows speeds and increases drivers' awareness
  - Reduces crashes (research has shown a 19 to 47 percent overall crash reduction after the implementation of street reconfigurations<sup>5</sup>)
- ▶ Multimodal accommodations
  - Provides the opportunity to repurpose paved areas into bicycle lanes and sidewalks for active transportation users
  - Provides exclusive space for each roadway user in a comfortable setting
  - Reduces crossing exposure to pedestrians and bicyclists

A street reconfiguration can provide benefits for all transportation modes and directly address the primary highway concerns in Oakridge: speed and safety. With a reduction in through lanes, it is necessary to identify if the study intersections will operate acceptability in the future under the new configuration. Appendix C includes the operation results for the study intersections along the highway in 2040 with a street reconfiguration. Based on the analysis, the study intersections are expected to operate acceptably in 2040 under a street reconfiguration scenario. Of the intersections on the highway, the average delay is expected to increase by less than two seconds with a street reconfiguration.

Table 14 provides a list of the proposed highway projects and the implementation needs with a street reconfiguration; some of the previously identified highway solutions overlap with the proposed street reconfiguration elements. Ideally, the street reconfiguration project would include all of these elements (lighting, crossings, etc.) for maximum benefit. The table summarizes those that are included in the basic cross section. Of the 13 identified highway projects, six would be addressed by the proposed street reconfiguration project and three would remain stand-alone projects. The remaining projects may be addressed by the street reconfiguration project; however, they should be further reevaluated after implementation. Projects such as crossing improvements should be monitored more closely to determine if and when implementation would be required.

---

<sup>5</sup> [https://safety.fhwa.dot.gov/road\\_diets/resources/pdf/get-the-facts062016.pdf](https://safety.fhwa.dot.gov/road_diets/resources/pdf/get-the-facts062016.pdf)

**Table 14. Project Needs with Street reconfiguration**

Project ID	Project Name	Implementation
R-5	OR 58 Illumination	Remains a project solution but can be implemented in conjunction with the street reconfiguration.
R-6	OR 58 Street Reconfiguration Pilot Project	Part of street reconfiguration project.
R-7	Long Term OR 58 Street Reconfiguration Project	Part of long-term street reconfiguration project.
S-1	Systemic safety intersection improvements on OR 58	Reevaluate the need after street reconfiguration, but additional signage and intersection visibility treatments can be implemented in conjunction with the street reconfiguration.
S-3	Intersection safety improvement at OR 58/Industrial Park Way (A)	Could be addressed with street reconfiguration, depending upon the extents of the project.
S-5	Speed feedback signs entering Oakridge (east and west)	Remains a project solution; implementing a street reconfiguration in conjunction with speed feedback signs is likely to achieve the highest speed compliance because drivers will see a visual change in context. The City would be required to coordinate with ODOT to approve and permit speed feedback signs within the ODOT right-of-way.
P-3	Sidewalks (both sides) or a multiuse path on OR 58	Part of long-term street reconfiguration project.
P-9	Traffic Signal Pedestrian Improvement at Crestview/OR 58	Remains a project solution but can be implemented in conjunction with the street reconfiguration.
B-6	Bicycle lanes on OR 58	Part of long-term street reconfiguration project.
C-4	OR 58/River Road-Thatcher Lane Pedestrian Safety Improvement	Consider implementing with the street reconfiguration. If not, reevaluate after street reconfiguration
C-5	OR 58/Rainbow Road Pedestrian Safety Improvement	Consider implementing with the street reconfiguration. If not, reevaluate after street reconfiguration
C-6	OR 58/Hill Street Pedestrian Safety Improvement	Consider implementing with the street reconfiguration. If not, reevaluate after street reconfiguration
C-7	OR 58/Union Street Pedestrian Safety Improvement	Consider implementing with the street reconfiguration. If not, reevaluate after street reconfiguration

### **OR 58 Street Reconfiguration Pilot Project (R-6)**

Before complete implementation of the long-term OR 58 street reconfiguration project (R-7), it is recommended that a pilot project be conducted. A pilot project is a temporary, low cost implementation of the cross section using temporary striping, planter boxes, traffic control barrels, and other delineating methods. It is set up for a specific duration of time (3 or more months) and is monitored during peak and non-peak periods. During the pilot project, observations and data should be collected to identify the safety, capacity, and operational effects of the street reconfiguration. To minimize cost of the pilot project, it is recommended that the pilot project be implemented on the highway between Thatcher Lane and Jones Road, where it can be implemented within existing pavement width. Implementation would include placement of traffic control barrels on the highway to provide travel lanes and separated multimodal space. Figure 24 shows a rendering and potential cross section for the pilot project.

A temporary street reconfiguration project presents the opportunity to explore this concept with reasonable investment before committing to a more permanent installation. A permanent street reconfiguration could be designed and implemented after the pilot project if the concept is supported by the project stakeholders.

Because the street reconfiguration project will remove the second lane in each direction, which is often provides passing opportunities within the City, this project would be best coordinated to occur with or after the implementation of the westbound passing lane on OR 58. ODOT is planning to construct a westbound passing lane on the highway from approximately milepost (MP) 31.6 and 32.4, starting about one mile west of Airport Road. The project is tentatively scheduled for 2024. By removing the passing lane from the City limits, the street reconfiguration supports reduced speeds, addressing one of the primary community concerns.

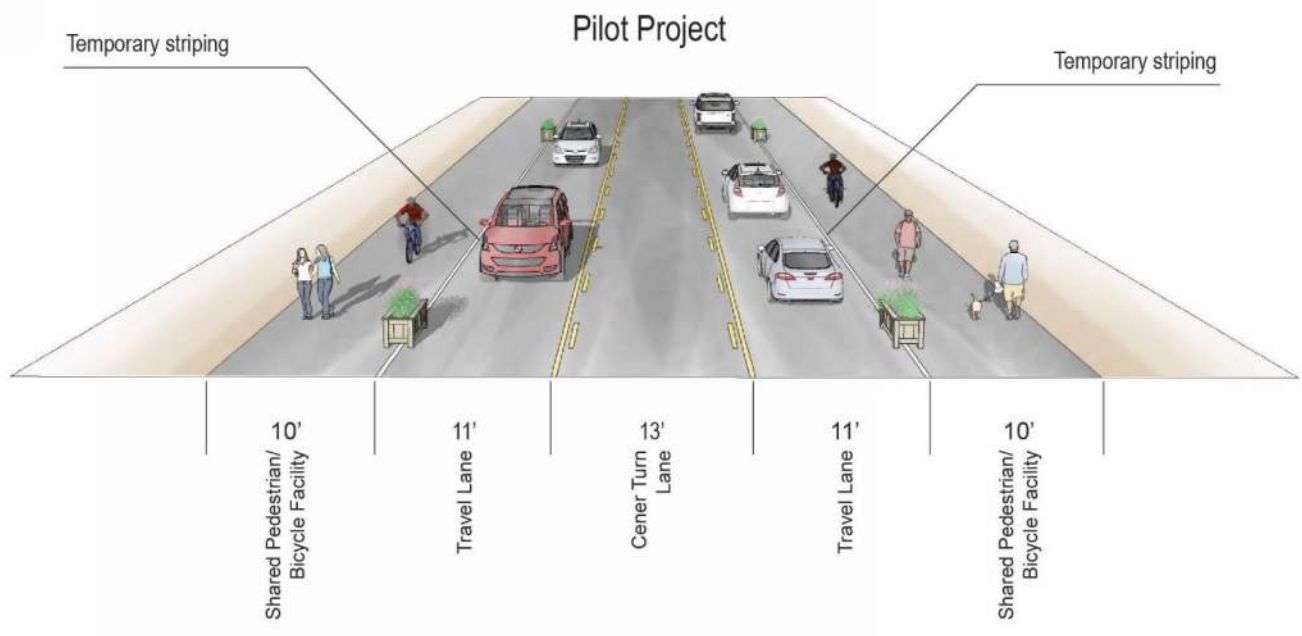
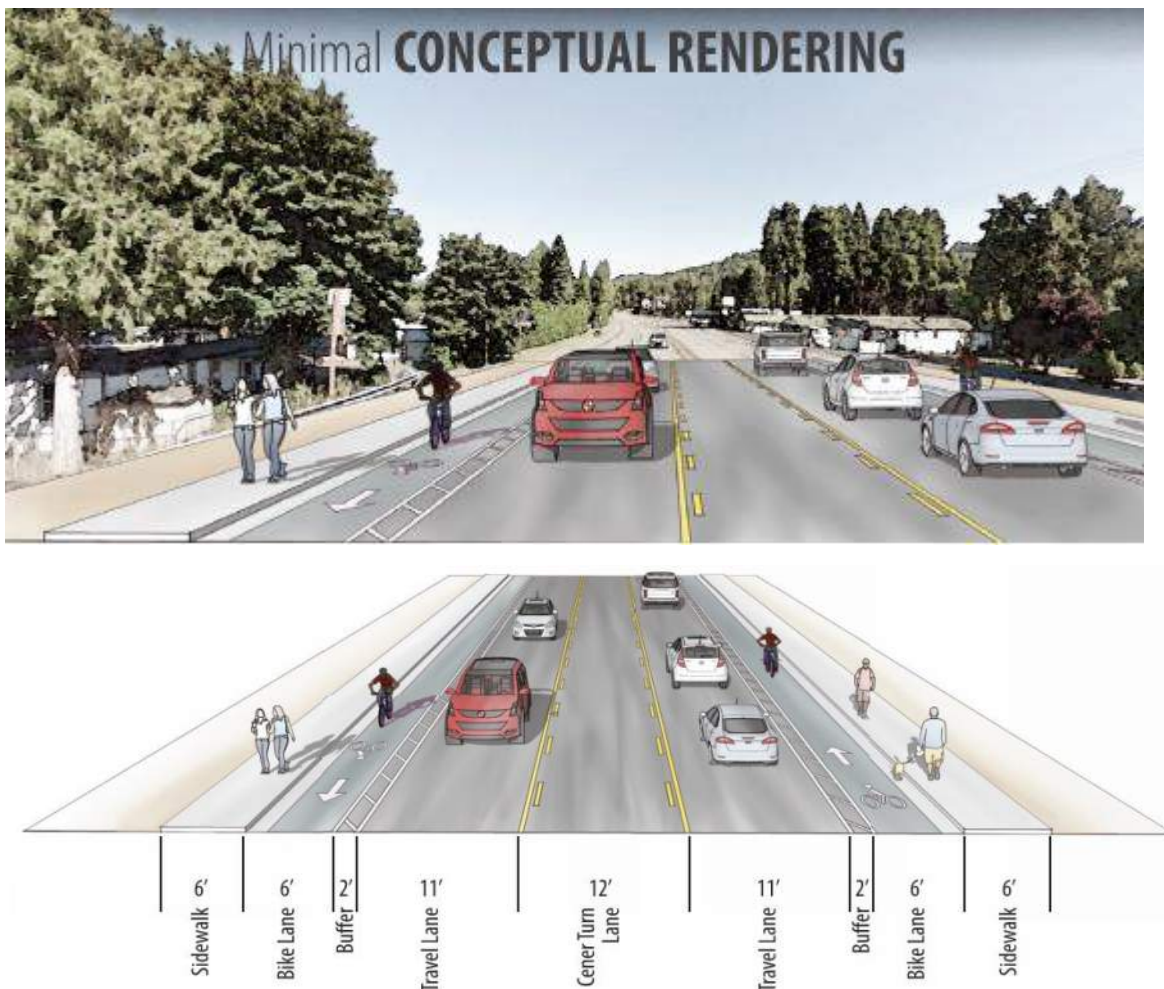

Figure 24. Pilot Project (above) rendering and (below) cross section

## Long-Term OR 58 Street Reconfiguration Project (R-7)

As described in the section above, a pilot project should be conducted before design and implementation of a permanent street reconfiguration project in Oakridge. A permanent street reconfiguration project would require additional design to include dedicated bicycle and pedestrian facilities and is likely to include widening in some locations. The cross section of the highway, after the reconfiguration, can vary based on the context of each section of the corridor. The right of way on OR 58 varies throughout the community from approximately 80-feet to 160-feet. Additionally, there are several businesses along the highway that appear to have parking areas or buildings within the public right of way. During the design process, all property and business owners along the highway will be contacted in regard access and improvements along their frontage.

Two conceptual renderings and cross sections were developed to show the street reconfiguration alternative. In areas where there is minimal right of way and pavement width, a reduced cross section may be appropriate. Figure 24 shows a minimum conceptual cross section design.



**Figure 24. Minimal Conceptual Cross section Design (above) rendering and (below) cross section**

In areas where the right-of way is wider, the cross section would include widened travel lane, a landscaping strip and wider sidewalk. Figure 25 shows a concept for an ideal cross section. In locations where there is existing sidewalk, the cross section may be designed to retain the sidewalk when possible. Before implementation, approval from the ODOT Motor Carrier Division and Oregon Transportation Commission would be required.

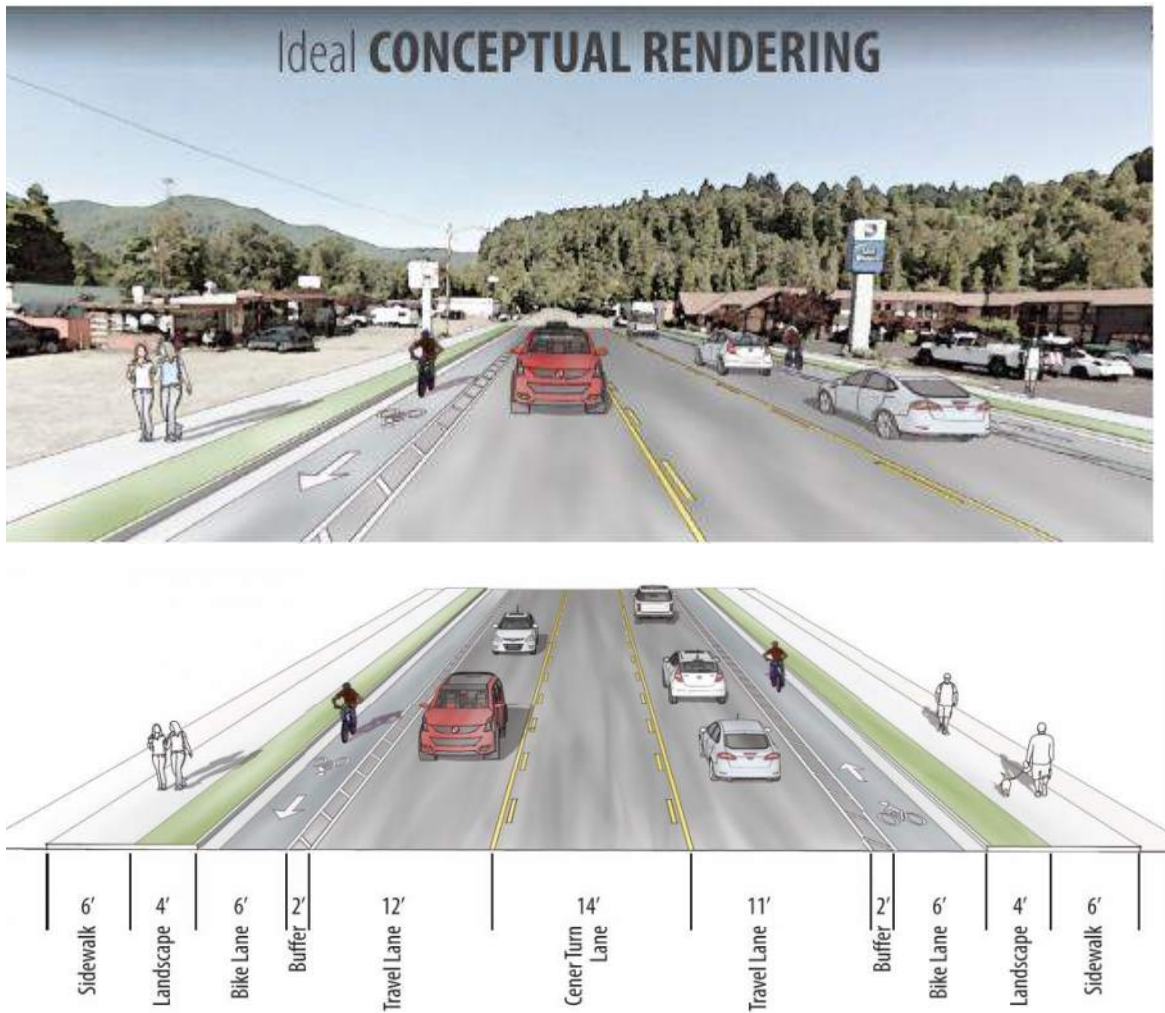

Figure 25. Conceptual Ideal Cross section Design (above) rendering and (below) cross section

## APPENDICES

Appendix A: 2000 TSP Project List

Appendix B: CTAA Meeting Notes

Appendix C: OR 58 Street reconfiguration Operations Analysis



## Appendix A – 2000 TSP Project List

Project	Cost Estimate	Status	Carried Forward in TSP Alternatives?	Justification
<b>2000 Oakridge Transportation System Plan</b>				
W 2nd St/Rose St roadway improvements	\$862,500	Complete		
Rainbow St roadway improvements	\$575,000	Partial	Yes	P-8, B-10
Ash Street drainage improvements	\$138,000	Complete		
Highway 58 Preservation - resurfacing MP 27.36 to 35.96	\$2,181,000	Complete		
Highway 58 Urban Standards roadway improvements	\$3,200,000	Incomplete	Partial	Several project elements included in TSP Update such as highway illumination (R-5), bike lanes (B-12), sidewalks (P-14)
Highway 58/Rainbow St safety improvements	\$150,000	Incomplete	Yes	Intersection system treatments (S-1), crossing treatment (C-5)
Highway 58/River Rd Intersection safety improvements	\$150,000	Incomplete	Yes	Intersection system treatments (S-1)
CMAQ improvements - paving of State St and the Public Works Maintenance Yard	\$212,750	Partial	Yes	PV-6
Highway 58 Operation and Safety Improvements at Industrial Parkway	\$550,000	Incomplete	Yes	S-3
Commercial St roadway and sidewalk improvements	\$86,250	Incomplete	Yes	P-1 and B-2
E 1st St roadway improvements	\$362,200	Incomplete	Yes	R-1
Garden St - roadway and sidewalk improvements	\$460,000	Partial	Yes	P-11 and B-8
Hills St - safety improvements	\$138,000	Incomplete	No	Hills Street/Y Drive not identified as a safety priority area in crash data or perceived unsafe locations
Industrial Parkway Extension - connect north side of mill pond to Fish Hatchery Rd	\$241,000	Incomplete	Yes	FC-7 and PV-4
Osprey Park Parking area at River Rd and Perkins St	\$13,800	Partial	Yes	PV-5
Salmon Creek Levee Multiuse Path - construct path and bridge crossing	\$655,500	Partial	Partial	The bridge project has been carried forward in SU-5
Improve Roads to Local Streets (7th St, Birch St, Jasper Dr, Teller St)	\$1,489,000	Partial	Yes	Local street paving program recommended in PV-1
Pedestrian Footbridge - Commercial St to Union St	Vision	Incomplete	Yes	C-2
Fish Hatchery Rd Bikeway - bike lane E 1st St to Highway 58	Vision	Partial	Yes	SU-2
Oak St/West oak Rd roadway and sidewalk improvements	Vision	Incomplete	Partial	A shared-use path is recommended in SU-1
Poplar St roadway and sidewalk improvements	Vision	Incomplete	Partial	Sidewalk infill recommended in P-3
Bikeways and Sidewalks for Arterials (Crestview St, E 1st St, W 2nd St)	Vision	Partial	Yes	R-1, R-4, P-2, P-5, P-6, P-7, B-1, B-3
Bikeways and Sidewalks for Collectors (W 2nd St, W 1st St, High Prairie Rd, Beech St, River Rd, School St, Union St, Rock Rd)	Vision	Partial	Yes	P-1, P-3, P-4, P-8, P-9, P-10, P-11, P-12, P-13, B-2, B-4, B-5, B-6, B-7, B-8, B-9, B-10, B-11
Fish Hatchery Rd Realignment approx. 750 ft west on Highway 58	Vision	Complete		
Crestview & 1st St - safety improvement	Vision	Incomplete	Yes	S-4
Elder St - signing and striping to convert to one-way	Vision	Incomplete	No	Need not identified in analysis or communication with city, advisory committee, or public
Industrial Parkway - resurfacing and drainage	Vision	Complete		
<b>2016 Oakridge Pedestrian Safety Plan</b>				
Rock Road, Jones Road Crossing Improvement	\$100,000	Complete		
River Road, Thatcher Road Crossing Improvement	\$50,000	Incomplete	Yes	C-4
Rainbow Road Crossing Improvement	\$50,000	Incomplete	Yes	C-5
Hills Street Crossing Improvement	\$50,000	Incomplete	Yes	C-6
Union Street Crossing Improvement	\$55,000	Incomplete	Yes	C-7
East of Jones Road Crossing Improvement	\$100,000	Incomplete	No	A RRFB was recently constructed approximately 600 feet west of Jones Road
Pedestrian Signal Improvements at Crestview Street/OR58	\$50,000	Incomplete	Yes	P-16
Sidewalk Infill - Phase 1	\$250,000	Incomplete	Yes	P-14
Sidewalk Infill - Phase 2	\$300,000	Incomplete	Yes	P-14
Speed Feedback Signs	\$40,000	Incomplete	Yes	S-5
Total Three Lane Conversion (roadway only)	\$130,000	Incomplete	Yes	R-7

## Appendix B – CTA Meeting Notes

# Technical Assistance Meeting Notes: Oakridge, Oregon

---



*November 2018*

*Prepared by Chris Zeilinger, Community Transportation Association of America*

## Introduction

As part of the technical assistance the Community Transportation Association of America (CTAA) is providing to the City of Oakridge and the Lane Council of Government (LCOG), Chris Zeilinger from the CTAA staff conducted a site visit and related meetings in Lane County in October 2018. Summary notes from these meetings and CTAA's observations are below.

As these notes indicate, CTAA identified some practical steps that state and local stakeholders should be taking with respect to enhancing Oakridge's economy through transportation improvements, and CTAA helped explore two specific enhancements of transit service for Oakridge that warrant serious consideration. CTAA also explored issues surrounding the concept of establishing Oakridge as a station stop for Amtrak's daily "Coast Starlight" passenger train.

This technical assistance is being provided through a cooperative agreement between CTAA and the Rural Business-Cooperative Service, USDA. All opinions and interpretations in the following notes are those of the author, and do not represent any official positions, findings or recommendations of the United States Government.

## CTAA's Meetings

### Meeting 1 – Thursday October 25, Kickoff Meeting

In attendance: Ellen Currier (LCOG), Kelly Clarke (LCOG), Kate Wilson (LCOG), John Ahlen (LTD), Chris Zeilinger (CTAA)

At this meeting, the attendees reviewed CTAA “baseline data” memo, which seemed reasonably correct. A copy of that memo is included as an appendix at the end of this document.

CTAA’s analysis identified several demonstrated aspects of transportation need, which were discussed in light of current “Diamond Express” bus service, possible Amtrak service or connections, and local mobility (modally agnostic) within Oakridge. Specifically, CTAA identified locally significant and largely un-met transportation need within the city of Oakridge, and CTAA substantiated a level of demand for transportation between Oakridge and the Eugene area that is largely satisfied with the Diamond Express (although opportunities for improving that service were identified and discussed).

The attendees at this meeting provided additional details to help start CTAA’s analysis. These included:

- Pacific Crest Bus Lines operates the Diamond Express under a contract administered by LTD. This is a fixed-route intercity bus service, with four round trips daily between Oakridge and Eugene, Monday through Friday (because of low ridership on one of the runs, the service was reduced to three daily round trips, starting November 1). Current operating funds for the Diamond Express are a mixture of state funds from ODOT, federal Section 5311(f) rural intercity bus funds (also administered by ODOT), and a fixed annual contribution from the city of Oakridge, along with fares paid by the service’s passengers. The contract with Pacific Crest also requires them to provide demand-response transportation within Oakridge two days a week for the purpose of transporting seniors to congregate meals at the Oakridge Senior Center on Tuesdays and Thursdays. That portion of the contract is supported largely with funding from LCOG’s Senior & Disability Services division.
- Years ago, Oakridge voted NOT to be part of the LTD service area. Within the LTD area, there is a stated payroll tax of 0.73% (for calendar year 2018) on most payrolls and self-employed persons’ net incomes. In lieu of LTD inclusion, the city of Oakridge has an intergovernmental agreement with LTD through which the city commits a fixed dollar amount as its contribution in support of the Diamond Express.
- The state-generated funds that historically have supported most of the Diamond Express’s operating costs are being transitioned to the recently enacted STIF, which will have different rules and procedures. That shift probably will not necessarily jeopardize funding for the Diamond Express, but does change some of the ground rules and procedures (for example, a major category of STIF funds cannot supplant currently used streams of transportation funding).

- Because so many of Oakridge's residents are low-income, Medicaid is a significant transportation factor. Most residents' medical destinations are in the Eugene area. LTD's RideSource paratransit operation is Oregon Health Plan's provider and broker of Medicaid non-emergency medical transportation for Lane County.
- Since at least 2009, Oakridge has been designated as a Clean Air Act nonattainment area on account of fine particulate matter (PM 2.5), and has been in nonattainment on account of particulate matter (PM 10.0) since 1998. As a result, the state of Oregon receives an annual CMAQ allocation from FHWA of approximately \$65,000 for the Oakridge area, but there is a large amount of unobligated CMAQ funds (more than \$500,000) attributed to Oakridge, and no ongoing plan for spending the area's annual CMAQ allocation.
- Since 2014 (or possibly earlier), the city of Oakridge has been in conversation with Amtrak and the Union Pacific Railroad about possible parameters around establishing a passenger rail station at which Amtrak's "Coast Starlight" train could stop once daily in each direction.
- LTD is planning to pilot test a "mobility on demand" transportation strategy in and around Cottage Grove; the lessons learned from that experience could be helpful in looking at Oakridge's mobility future.

Upon discussing the above points, the group asked that CTAA help provide details to prioritize these possibilities:

- Improved connectivity between the Diamond Express and intercity rail and bus service in Eugene;
- Expanded local transit service within Oakridge;
- Adding Saturday and Sunday service to the Diamond Express; and
- Helping determine how best to consider the feasibility of establishing an Amtrak stop in Oakridge.

## **Meeting 2 – Friday October 26, Oakridge Site Visit**

In attendance: Louis Gomez (city of Oakridge), Rick Zylstra (city of Oakridge), Lynda Kamerrer, Chris Zeilinger (CTAA)

These key local stakeholders validated CTAA's initial data, and confirmed much of what was discussed at the previous day's kickoff meeting with LCOG. A few more salient details emerged in this meeting, such as:

- There is noticeable commuter travel in both directions between Oakridge and the Eugene area. Not only are Eugene destinations important for many of Oakridge's employed residents, but most of the major employers in Oakridge (e.g., the Oakridge School District, the US Forest Service, and the Union Pacific Railroad) draw much of their workforce from the Eugene area.
- While there is a recognized need for additional transportation service within Oakridge, it's not likely to be geared around transporting currently non-working Oakridge residents to jobs in Oakridge. Most of the lower-wage job growth in Oakridge is in the hospitality, tourism and retail sectors, all of which are predicated on workers' abilities to work diverse and flexible hours (i.e., not likely to be well-served by transit).
- To some degree, there is a desire for transportation connections with Amtrak to make it possible for mountain bikers (the mainstay of Oakridge's tourism economy) to come to town for a weekend, without cars, and be able to leave after enjoying a car-free weekend of outdoor recreation in and around Oakridge. One or two local outdoors recreation companies in Oakridge will transport people and bikes to and from trailheads, but no one will transport visitors from Eugene or beyond. Even for weekday visitors, one drawback is the use of standard transit coaches for the current Diamond Express service, which limits the ability for visitors to travel with their bags and bikes.
- The decision for Oakridge not to become part of the Lane Transit District service area was made many years ago. In general, for an area to be added to the LTD area requires an affirmative majority vote both of all voters within the existing LTD area, as well as an affirmative majority vote of all voters within the area seeking to be added to the LTD area. There is an area-wide payroll tax rate of 0.73% (in 2018, increasing to 0.74% in calendar year 2019) that supports LTD. If the city of Oakridge were to be voted into the LTD service area, payrolls in the city collectively would bear approximately \$20,000 per year in the LTD payroll tax; in contrast, the city currently pays approximately \$12,000 per year out of its general revenues to help support the Diamond Express.

Within Oakridge, the priorities were consistent with what was expressed at the kickoff meeting:

- Improve connectivity between Oakridge and Eugene;
- Expand local transportation service within Oakridge;

- Provide some degree of weekend Diamond Express service, geared especially for travel and tourism; and
- Pursue the establishment of an Amtrak stop in Oakridge

### Meeting 3 – Friday October 26, CTAA Observations

In attendance: Andy Vobora (Travel Lane County), Mark Bernard (ODOT), Ellen Currier (LCOG), Kate Wilson (LCOG), [someone else from LCOG], Chris Zeilinger (CTAA)

At this meeting, CTAA shared its observations and preliminary ideas about how to enhance the economic vitality of Oakridge through strategic transportation improvements. These observations fell out across several thematic areas, as detailed below.

- **Make sure local mobility and intercity connectivity are addressed in the upcoming Oakridge Transportation System Plan (TSP) update.** In November, the city launched its TSP update, which is being carried out by the consulting firm Kittelson & Associates. The priorities addressed in this long-range plan are those that will shape future programming of transportation dollars to the community.
- **Develop strategies for pursuing and using Oakridge’s CMAQ funds.** To be sure, these funds are a challenge to be used effectively, in that the city’s air quality issues are not caused by transportation factors, and probably cannot be significantly improved through transportation measures. Nonetheless, the city should engage aggressively with ODOT about how best to use these dollars within their allowed purposes. For instance, it may be possible to use CMAQ funds in ways that minimize personal vehicular travel, such as through active transportation (i.e., bicycle and pedestrian) improvements in Oakridge or for local and intercity transportation capital improvements that reduce the incidence of personal vehicle use among Oakridge residents (e.g., an additional transit vehicle for in-town use, capital improvements to vehicles used on the Diamond Express that enhance their use by tourists and commuters, or marketing efforts that increase local and intercity transit use by Oakridge residents).
- **Determine how quickly the twice-weekly senior transportation service within Oakridge can be expanded to five days a week, and begin planning for that expansion.** The primary customer base for this service is likely to be the city’s older residents, but the service expansion should create mobility options for other city residents with transportation challenges, whether on account of age, income or disability. For planning purposes, it’s reasonable to estimate this expansion would require between \$75,000 and \$100,000 a year in additional transit funding to Oakridge, and may require funding for additional capital assets. Since the city has a high percentage of low-income households, there’s a good chance that this



expansion could be supported in large part through the state's STIF program. Note that expanding this transit service within Oakridge could advise some simplification of route that the Diamond Express service uses within the city.

- **Improve connectivity between the Diamond Express and Eugene's intercity rail service.** Currently, Amtrak's schedules do not indicate any opportunity to connect with the Diamond Express for service between Eugene and Oakridge. That needs to be addressed as immediately as possible, insofar as intercity connectivity is a requirement for using Section 5311(f) funds to support the Diamond Express. In addition, at least one southbound Amtrak arrival in Eugene should have an easy and efficient transfer to a Diamond Express departure to Oakridge, and at least one Diamond Express arrival in Eugene should have an easy and efficient transfer to a northbound Amtrak departure from Eugene.
- **Determine how quickly a pilot program of weekend Diamond Express operation could be launched, secure necessary funding, and carry out this pilot.** This service would be more limited in hours than the weekday Diamond Express operation (ideally, two round trips daily, but if funding is limited, one daily round trip on Saturdays and Sundays is better than nothing), and would have considerably lower ridership than the weekday service, especially at first, but that should not be a discouragement. Without this pilot, it's hard to discern whether the weekend ridership would be tourists and recreational users, or if it would be Oakridge residents seeking to better access jobs, services or shopping in Eugene; all of those – or maybe even other market segments – are possible. It may be possible to launch such a pilot program for as little as \$30,000 a year in operating costs.
- **Explore the details about establishing an Amtrak stop, then decide whether this is something to pursue.** At first blush, it would appear the costs of this would be high, and probably would result in only a few train boardings per month. Because the route through Oakridge is a single-track mainline owned and operated by Union Pacific, the railroad would require construction of a new siding alongside Commercial Street, with necessary power switches and signaling system integration; the estimated costs for this construction are between \$5 million and \$8 million. Amtrak would require construction of a level passenger platform at least 1200 feet long, and up to 15 feet wide, with a shelter for waiting passengers, a certain amount of signage specified by Amtrak, enough lighting to assure safety and security, an emergency call box, and arrangements for trash collection and snow removal. Amtrak also would require the facility to have some ready means by which emergency or maintenance vehicles can come to trackside if necessary, and would require there to be some ADA-compliant means by which passengers with disabilities can achieve level boarding and exiting from rail cars. Ideally, there would be fencing to discourage, if not prevent, persons from accessing the active rail mainline from the station area. Amtrak would not expect there to be any more of a structure than a simple shelter and platform. The station would not be staffed,

would not be equipped to handle the checking of baggage, and Amtrak would not require there to be any on-site “QuikTrak” machines for purchasing or printing passengers’ Amtrak tickets. Amtrak has a demand estimation methodology that is conservative, but fairly reliable, which can produce likely level of usage at an Oakridge station stop.

## Summary of Oakridge Transit Options

As the above observations indicate, much of what’s most important to Oakridge’s transit future is tied to practical, tactical steps: looking at ways to make effective use of the city’s CMAQ funds, making sure that transit-related needs and priorities are included in the just-launched TSP update, and working with LTD to ensure that the existing weekday Diamond Express is better marketed and linked to Eugene’s rail service.

In addition, two operational strategies warrant serious consideration, either together or separately. They are:

- **Establish transit service within Oakridge five days a week.** This would be an increase from the twice-weekly senior transportation service already in place. It could be either a demand-response operation (as currently is the case), or possibly a bus running on a regularly scheduled loop through the city, deviating off-route as necessary for the needs of customers with disabilities. The cost of expanding the current service to five days a week would be up to \$100,000 per year, much of which may be able to be borne by federal and state funds. Likely ridership of this expansion would be around 4,000 one-way passenger trips per year, in addition to the current ridership of the existing senior transportation service. Aside from additional hours of employment in the transportation sector, there would be few if any jobs created in Oakridge through this measure, but there would be social benefits, and perhaps some modest economic benefits, as more Oakridge residents are able to live more independently and enjoy some more economic interaction with the community.
- **Establish a pilot program of limited Diamond Express operations on weekends.** This probably would involve two round trips daily between Eugene and Oakridge on both Saturdays and Sundays, at a cost of up to \$60,000 per year, much of which may be able to be borne by federal and state funds. Because it would be a pilot program, ridership is hard to predict (and the ridership composition is even harder to predict), but a reasonable estimate would be as much as 2,400 one-way weekend passenger trips per year. There are a number of reasonably likely economic benefits under this strategy: (1) there would be a modest increase in transportation workforce employment associated with operating the additional

service, (2) a small number (probably 4 or fewer) currently non-working Oakridge residents may be able to enter and remain in the Eugene-area workforce on account of being able to commute on weekends as well as weekdays, (3) if properly marketed and connected with both Amtrak and LTD services in Eugene, there would be an increase in tourism and tourist-related spending in Oakridge as people use the weekend Diamond Express service for accessing recreational opportunities in the Oakridge area, and (4) more residents of Oakridge would be able access medical, social and economic activities in Eugene, on account of the weekend Diamond Express service.

As for the establishment of an Amtrak stop in Oakridge, that is a higher-profile, higher-cost strategy that warrants serious consideration, especially when looking at how or whether to finance the effort. As a driver of economic improvement in Oakridge, such an effort would yield some positive results over time, both in terms of construction-related employment and in terms of the economic and social benefit of “putting Oakridge on the map” as a place to access by train and that is welcoming to tourists from both near and far. On the other hand, it would be a lot of investment that would be needed, all for the opportunity to have one train a day in each direction stop in the city for loading and unloading what’s likely to be a modest number of passengers.

# APPENDIX: Technical Assistance Initial Baseline Data, Oakridge, Oregon

---

October 2018

Prepared by Chris Zeilinger, Community Transportation Association of America

## Background

At the request of the City of Oakridge and the Lane Council of Governments (LCOG), the Community Transportation Association of America (CTAA) is examining how the city of Oakridge may be able to enhance its economic vitality through strategic transportation improvements. CTAA will be conducting a site visit on October 2018 at which facts on the ground will be reviewed and meetings with key stakeholders in the area will inform the most promising actions to consider. In anticipation of those meetings, this initial technical report summarizes key aspects of community demographics and economic indicators, travel patterns, and transportation resources.

## Baseline Information

Oakridge is an incorporated city in the rural area of Lane County, Oregon. It is approximately 45 miles southeast of Eugene, Oregon. Its population in the 2010 census was 3,205, and current census estimates are that its population continues to be just over 3,200 persons. With a land area of 2.1 square miles, Oakridge is a rather compact city, having a population density of approximately 1,525 persons per square mile.

Historically, Oakridge's economy was driven by the timber industry, but that came to an end when the former Pope & Talbot mill ceased operations in 1990. Since then, the city's economy has moved in a somewhat different direction. Today, the U.S. Forest Service is the second largest employer of Oakridge residents; the Oakridge School District is the largest single employer within the city.

Unemployment is high in Oakridge. According to U.S. Census American Community Survey data, 15.1 percent of Oakridge's labor force was unemployed in 2016 (in contrast, the comparable unemployment rate for the state of Oregon was 8.1 percent). Among Oakridge residents who are employed, most of their jobs are out of town, primarily in the Eugene urbanized area.

## **Selected Demographic Data**

### **Population (2016 estimate)**

- Oakridge: 3,202

### **Population age 65+ (2016)**

- Oakridge: 958 (29.9% of population; statewide, 15.9% of all Oregonians are 65+)

### **Population with disabilities (2016)**

- Oakridge: 932 (29.1% of population; statewide, 14.7% of all Oregonians report a disability)

## **Income, Poverty and Employment Data**

### **Per capita income (2016)**

- Oakridge: \$18,945
- Oregon (statewide): \$28,822

### **Median household income (2016)**

- Oakridge: \$32,394
- Oregon (statewide): \$53,270

### **Households with income below \$15,000 (2016)**

- Oakridge: 284 households (17.5% of households)
- Oregon (statewide): 12.0% of households

### **Population living in households with income below poverty (2016)**

- Oakridge: 950 (29.7% of population; statewide, 15.7% of Oregonians live in poverty)

### **Population living in households without vehicles (2016)**

- Oakridge: 132 (6.3% of Oakridge households have no vehicle, compared with 7.9% of all Oregon households)

### **Unemployed persons in workforce and rate of unemployment (2015)**

- Oakridge: 195 unemployed adults (15.1% of labor force, compared with 8.1% of Oregon's statewide labor force being unemployed)

### **Sectors in which Oakridge residents are employed (2016)**

- Education, health care, social assistance: 209 jobs (19.1% of employed residents)
- Accommodation, food service, arts & entertainment, recreation: 191 jobs (17.5% of employed residents)
- Construction: 156 jobs (14.3% of employed residents)
- Agriculture & forestry, fishing & hunting, mining: 150 jobs (13.7% of employed residents)
- Retail trade: 109 jobs (10.0% of employed residents)
- Real estate, finance & insurance: 79 jobs (7.2% of employed residents)
- Manufacturing: 64 jobs (5.9% of employed residents)
- Transportation & warehousing, utilities: 38 jobs (3.5% of employed residents)

- Professional, administrative and/or managerial: 15 jobs (1.4% of employed residents)
- Other services: 82 jobs (7.5% of employed residents)

## **Where People Work, and How They Commute**

### **Employed persons living in Oakridge, 2016: 1,093**

- Live and work in Oakridge: 26.5% of employed residents
- Commute to jobs in Eugene, Springfield or Coburg: 31.2% of employed residents
- Commute to jobs elsewhere in Lane County: 12.8% of employed residents
- Commute to jobs outside Lane County: 29.5%

### **How employed Oakridge residents commute (2016)**

- Commute via single-occupancy personal vehicle or motorcycle: 58.4% of employed residents
- Carpool to work: 5.1% of employed residents
- Walk or bike to work: 27.8% of employed residents
- Commute by transit: 1.7% of employed residents
- Work at home: 10.2% of employed residents

### **Length of commute among employed Oakridge residents (2016)**

- Less than 10 miles: 29.9% of employed residents
- Between 10 and 25 miles: 0.5% of employed residents
- Between 25 and 50 miles: 40.6% of employed residents
- More than 50 miles: 29.0% of employed residents

**Number of employed Oakridge residents who do not have a vehicle in their household, 2016: None**

## **Patterns of Rural Transit Need and Demand in Oakridge**

There are a number of tools and techniques that can be used to identify and explore the demand for public transit in rural communities. One generally accepted approach for forecasting demand and quantifying the need for transit services in smaller communities has been validated over time and is published by the National Academy of Sciences as Transit Cooperative Research Program (TCRP) Report 161, *Methods for Forecasting Demand and Quantifying Need for Rural Passenger Transportation.* Based on that report's model, the following elements of transit demand begin to emerge:

### **A. Local transit demand within Oakridge: approximately 5,900 one-way trips per year**

The likeliest consumers of transit within Oakridge are its older adults (29.9 percent of the city's population is over the age of 65), residents with disabilities (29.1 percent of the city's population has some form of disability), and its households with income below poverty (29.7 percent of the city's population lives in households with income below the federal poverty line). Note that there is no local transit service within Oakridge.

### **B. Intercity transportation between Oakridge and Eugene: at least 1,500 one-way trips per year**

Calculating demand for long-distance transit commutes between a small rural community and an urban core more than 40 miles away is an imprecise exercise. The TCRP methodology assumes that 1.0 percent of all known commuters in any given rural-urban city pair are likely to be willing to use transit for these commutes, which is how the above figure of 1,500 trips per year is calculated. However, ACS data show that 1.7 percent of workers who live in Oakridge commute to work via transit; inasmuch as there is no local transit in Oakridge, all those trips must be to the Eugene area, which suggests a somewhat more realistic demand for 2,550 one-way passenger trips along that route. Since the “Diamond Express” service that connects Oakridge, Westfir and Eugene has been in operation since 2003, it would be critically important to examine the actual experience over the past 14 years to see how well this market is being served.

Based on the above analysis and other information provided during the course of initiating this project, CTAA suggests that there are five transportation-related questions to be explored through this technical assistance:

1. Is there a need to address local transit need within the city of Oakridge, especially with respect to the mobility needs of the city’s transportation-challenged residents?
2. To what extent is the current Diamond Express service satisfying (or not satisfying) the needs to transport people between Oakridge and Eugene?
3. Are there destinations other than Eugene to which significant numbers of Oakridge residents need to have regular transportation?
4. Is Oakridge itself a destination that requires additional intercity bus service from Eugene or elsewhere?
5. Would the benefits that might accrue from establishing an Amtrak stop in Oakridge be sufficiently likely and significant to justify the expense and effort of working with the Union Pacific Railroad and with Amtrak?

## Appendix C: OR 58 Street reconfiguration Operations Analysis



Intersection												
Int Delay, s/veh	1.6											
Movement	EBL	EBT	EBR	WBL	WBT	WBR	NBL	NBT	NBR	SBL	SBT	SBR
Lane Configurations	↖	↗		↖	↗			↕			↕	
Traffic Vol, veh/h	16	367	30	16	317	12	10	7	11	16	3	17
Future Vol, veh/h	16	367	30	16	317	12	10	7	11	16	3	17
Conflicting Peds, #/hr	0	0	0	0	0	0	0	0	2	2	0	0
Sign Control	Free	Free	Free	Free	Free	Free	Stop	Stop	Stop	Stop	Stop	Stop
RT Channelized	-	-	None	-	-	None	-	-	None	-	-	None
Storage Length	150	-	-	150	-	-	-	-	-	-	-	-
Veh in Median Storage, #	-	0	-	-	0	-	-	0	-	-	0	-
Grade, %	-	0	-	-	0	-	-	0	-	-	0	-
Peak Hour Factor	95	95	95	95	95	95	95	95	95	95	95	95
Heavy Vehicles, %	31	45	20	31	61	50	12	17	22	31	67	43
Mvmt Flow	17	386	32	17	334	13	11	7	12	17	3	18

Major/Minor	Major1			Major2			Minor1			Minor2		
Conflicting Flow All	347	0	0	418	0	0	821	817	404	823	827	341
Stage 1	-	-	-	-	-	-	436	436	-	375	375	-
Stage 2	-	-	-	-	-	-	385	381	-	448	452	-
Critical Hdwy	4.41	-	-	4.41	-	-	7.22	6.67	6.42	7.41	7.17	6.63
Critical Hdwy Stg 1	-	-	-	-	-	-	6.22	5.67	-	6.41	6.17	-
Critical Hdwy Stg 2	-	-	-	-	-	-	6.22	5.67	-	6.41	6.17	-
Follow-up Hdwy	2.479	-	-	2.479	-	-	3.608	4.153	3.498	3.779	4.603	3.687
Pot Cap-1 Maneuver	1067	-	-	1001	-	-	282	295	605	261	244	617
Stage 1	-	-	-	-	-	-	580	555	-	591	518	-
Stage 2	-	-	-	-	-	-	618	588	-	538	475	-
Platoon blocked, %	-	-	-	-	-	-	-	-	-	-	-	-
Mov Cap-1 Maneuver	1067	-	-	1001	-	-	264	285	604	244	236	617
Mov Cap-2 Maneuver	-	-	-	-	-	-	264	285	-	244	236	-
Stage 1	-	-	-	-	-	-	571	546	-	582	509	-
Stage 2	-	-	-	-	-	-	586	578	-	511	467	-

Approach	EB			WB			NB			SB		
HCM Control Delay, s	0.3			0.4			16.3			16.9		
HCM LOS							C			C		

Minor Lane/Major Mvmt	NBLn1	EBL	EBT	EBR	WBL	WBT	WBR	SBLn1
Capacity (veh/h)	347	1067	-	-	1001	-	-	340
HCM Lane V/C Ratio	0.085	0.016	-	-	0.017	-	-	0.111
HCM Control Delay (s)	16.3	8.4	-	-	8.7	-	-	16.9
HCM Lane LOS	C	A	-	-	A	-	-	C
HCM 95th %tile Q(veh)	0.3	0	-	-	0.1	-	-	0.4

Intersection						
Int Delay, s/veh	1.6					
Movement	EBT	EBR	WBL	WBT	NBL	NBR
Lane Configurations	↔		↔	↑	↔	↔
Traffic Vol, veh/h	389	28	17	405	29	75
Future Vol, veh/h	389	28	17	405	29	75
Conflicting Peds, #/hr	0	0	0	0	0	0
Sign Control	Free	Free	Free	Free	Stop	Stop
RT Channelized	-	None	-	None	-	None
Storage Length	-	-	200	-	100	0
Veh in Median Storage, #	0	-	-	0	0	-
Grade, %	0	-	-	0	0	-
Peak Hour Factor	95	95	95	95	95	95
Heavy Vehicles, %	41	48	42	44	29	37
Mvmt Flow	409	29	18	426	31	79

Major/Minor	Major1	Major2	Minor1		
Conflicting Flow All	0	0	438	0	886
Stage 1	-	-	-	-	424
Stage 2	-	-	-	-	462
Critical Hdwy	-	-	4.52	-	6.69
Critical Hdwy Stg 1	-	-	-	-	5.69
Critical Hdwy Stg 2	-	-	-	-	5.69
Follow-up Hdwy	-	-	2.578	-	3.761
Pot Cap-1 Maneuver	-	-	939	-	283
Stage 1	-	-	-	-	606
Stage 2	-	-	-	-	581
Platoon blocked, %	-	-	-	-	-
Mov Cap-1 Maneuver	-	-	939	-	278
Mov Cap-2 Maneuver	-	-	-	-	391
Stage 1	-	-	-	-	594
Stage 2	-	-	-	-	581

Approach	EB	WB	NB
HCM Control Delay, s	0	0.4	13.2
HCM LOS			B

Minor Lane/Major Mvmt	NBLn1	NBLn2	EBT	EBR	WBL	WBT
Capacity (veh/h)	391	562	-	-	939	-
HCM Lane V/C Ratio	0.078	0.14	-	-	0.019	-
HCM Control Delay (s)	15	12.5	-	-	8.9	-
HCM Lane LOS	C	B	-	-	A	-
HCM 95th %tile Q(veh)	0.3	0.5	-	-	0.1	-

Queues  
3: OR 58 & Crestview

02/05/2019

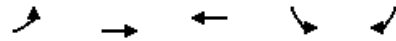

Lane Group	EBL	EBT	WBT	SBL	SBR
Lane Group Flow (vph)	179	298	373	17	105
v/c Ratio	0.38	0.35	0.68	0.11	0.46
Control Delay	5.4	4.8	19.5	27.6	14.1
Queue Delay	0.0	0.0	0.0	0.0	0.0
Total Delay	5.4	4.8	19.5	27.6	14.1
Queue Length 50th (ft)	13	28	87	5	0
Queue Length 95th (ft)	41	80	218	25	43
Internal Link Dist (ft)		595	706	893	
Turn Bay Length (ft)	200				100
Base Capacity (vph)	528	1074	926	709	665
Starvation Cap Reductn	0	0	0	0	0
Spillback Cap Reductn	0	0	0	0	0
Storage Cap Reductn	0	0	0	0	0
Reduced v/c Ratio	0.34	0.28	0.40	0.02	0.16

Intersection Summary

HCM 6th Signalized Intersection Summary  
 3: OR 58 & Crestview

02/05/2019



Movement	EBL	EBT	WBT	WBR	SBL	SBR
Lane Configurations						
Traffic Volume (veh/h)	170	283	338	16	16	100
Future Volume (veh/h)	170	283	338	16	16	100
Initial Q (Qb), veh	0	0	0	0	0	0
Ped-Bike Adj(A_pbT)	1.00			1.00	1.00	1.00
Parking Bus, Adj	1.00	1.00	1.00	1.00	1.00	1.00
Work Zone On Approach		No	No		No	
Adj Sat Flow, veh/h/ln	1013	986	945	945	1122	1095
Adj Flow Rate, veh/h	179	298	356	17	17	105
Peak Hour Factor	0.95	0.95	0.95	0.95	0.95	0.95
Percent Heavy Veh, %	54	56	59	59	46	48
Cap, veh/h	338	667	420	20	138	120
Arrive On Green	0.13	0.68	0.47	0.47	0.13	0.13
Sat Flow, veh/h	965	986	894	43	1069	928
Grp Volume(v), veh/h	179	298	0	373	17	105
Grp Sat Flow(s),veh/h/ln	965	986	0	937	1069	928
Q Serve(g_s), s	4.5	6.9	0.0	17.2	0.7	5.4
Cycle Q Clear(g_c), s	4.5	6.9	0.0	17.2	0.7	5.4
Prop In Lane	1.00			0.05	1.00	1.00
Lane Grp Cap(c), veh/h	338	667	0	440	138	120
V/C Ratio(X)	0.53	0.45	0.00	0.85	0.12	0.88
Avail Cap(c_a), veh/h	434	1250	0	900	699	607
HCM Platoon Ratio	1.00	1.00	1.00	1.00	1.00	1.00
Upstream Filter(l)	1.00	1.00	0.00	1.00	1.00	1.00
Uniform Delay (d), s/veh	9.2	3.7	0.0	11.4	18.8	20.9
Incr Delay (d2), s/veh	1.3	0.7	0.0	6.9	0.4	17.4
Initial Q Delay(d3),s/veh	0.0	0.0	0.0	0.0	0.0	0.0
%ile BackOfQ(50%),veh/ln	0.6	0.7	0.0	3.4	0.2	0.6
Unsig. Movement Delay, s/veh						
LnGrp Delay(d),s/veh	10.5	4.4	0.0	18.3	19.2	38.3
LnGrp LOS	B	A	A	B	B	D
Approach Vol, veh/h		477	373		122	
Approach Delay, s/veh		6.7	18.3		35.6	
Approach LOS		A	B		D	
Timer - Assigned Phs		2		4	5	6
Phs Duration (G+Y+Rc), s		38.6		10.3	10.1	28.5
Change Period (Y+Rc), s		5.5		4.0	4.0	5.5
Max Green Setting (Gmax), s		62.0		32.0	11.0	47.0
Max Q Clear Time (g_c+I1), s		8.9		7.4	6.5	19.2
Green Ext Time (p_c), s		3.2		0.4	0.2	3.8
<b>Intersection Summary</b>						
HCM 6th Ctrl Delay			14.8			
HCM 6th LOS			B			
<b>Notes</b>						
User approved pedestrian interval to be less than phase max green.						

Intersection						
Int Delay, s/veh	1.9					
Movement	EBL	EBT	WBT	WBR	SBL	SBR
Lane Configurations	↘	↑	↗		↘	
Traffic Vol, veh/h	61	225	297	12	13	45
Future Vol, veh/h	61	225	297	12	13	45
Conflicting Peds, #/hr	1	0	0	1	2	0
Sign Control	Free	Free	Free	Free	Stop	Stop
RT Channelized	-	None	-	None	-	None
Storage Length	200	-	-	-	0	-
Veh in Median Storage, #	-	0	0	-	0	-
Grade, %	-	0	0	-	0	-
Peak Hour Factor	95	95	95	95	95	95
Heavy Vehicles, %	53	59	57	60	64	59
Mvmt Flow	64	237	313	13	14	47

Major/Minor	Major1	Major2	Minor2		
Conflicting Flow All	327	0	-	0	688 321
Stage 1	-	-	-	-	321 -
Stage 2	-	-	-	-	367 -
Critical Hdwy	4.63	-	-	-	7.04 6.79
Critical Hdwy Stg 1	-	-	-	-	6.04 -
Critical Hdwy Stg 2	-	-	-	-	6.04 -
Follow-up Hdwy	2.677	-	-	-	4.076 3.831
Pot Cap-1 Maneuver	995	-	-	-	331 606
Stage 1	-	-	-	-	615 -
Stage 2	-	-	-	-	583 -
Platoon blocked, %		-	-	-	
Mov Cap-1 Maneuver	994	-	-	-	309 605
Mov Cap-2 Maneuver	-	-	-	-	389 -
Stage 1	-	-	-	-	575 -
Stage 2	-	-	-	-	582 -

Approach	EB	WB	SB
HCM Control Delay, s	1.9	0	12.5
HCM LOS			B

Minor Lane/Major Mvmt	EBL	EBT	WBT	WBR	SBLn1
Capacity (veh/h)	994	-	-	-	538
HCM Lane V/C Ratio	0.065	-	-	-	0.113
HCM Control Delay (s)	8.9	-	-	-	12.5
HCM Lane LOS	A	-	-	-	B
HCM 95th %tile Q(veh)	0.2	-	-	-	0.4



Volume II – Appendix F  
**Technical Memorandum #6**

# MEMORANDUM #6

**Date:** July 15, 2019  
**To:** Rick Zylstra (City of Oakridge)  
 David Helton (Oregon Department of Transportation)

Project #: 22477

**From:** Ashleigh Ludwig, PE, Marc Butorac, PE and Jacki Gulczynski (Kittelison & Associates, Inc.)

**Project:** City of Oakridge Transportation System Plan Update

**Subject:** Memorandum #6: Costs and Potential Funding Strategies for Proposed Improvements

## INTRODUCTION

This memorandum provides a summary of the existing and potential funding sources as identified in Technical Memorandum #3 and provides planning level cost estimates for projects as described in Technical Memorandum #5. The projects are prioritized (high, medium, and low) based on the TSP goals and objectives identified in Technical Memorandum #2 and input from the Project Advisory Committee, the City and ODOT. This memorandum also addresses funding projection needs to develop and support recommendations for a preferred plan and for a financially-constrained plan.

## TABLE OF CONTENTS

<b>INTRODUCTION .....</b>	<b>1</b>
Table of Contents .....	1
<b>EXECUTIVE SUMMARY .....</b>	<b>1</b>
<b>01   TRANSPORTATION PRIORITIES AND EVALUATION CRITERIA .....</b>	<b>2</b>
<b>02   HISTORIC FUNDING OVERVIEW .....</b>	<b>3</b>
<b>03   PLANNING LEVEL COST ESTIMATES .....</b>	<b>4</b>
Street System Solutions.....	4
Safety Solutions .....	11
Pedestrian System Solutions .....	13
Bicycle System Solutions .....	18
Transit, Rail, and Air System Solutions .....	21
Implementation Solutions.....	25
<b>04   FUTURE TRANSPORTATION FUNDING PLAN.....</b>	<b>25</b>

## EXECUTIVE SUMMARY

The outcome of this memorandum is a list of priorities and potential funding sources to support the City in developing a Capital Improvement Project list. The historical funding evaluation (see Technical Memorandum #3) showed that the City has incurred approximately a \$10,000 deficit each year since 2013 simply to maintain existing roadways. If the spending trend were to continue without additional funding sources, the City Street Fund would last less than ten years and no capital projects could be completed. Based on the project list developed in Technical Memorandum

#5, the City would require approximately \$22 million in net new funding over the next 20 years to fund all the identified high, medium, and low priority projects. As such, the City would need to generate approximately \$1 million per year in new revenue to support all the identified Capital Improvement Projects identified in the draft Plan.

Potential strategies for addressing the funding gap in Oakridge may generally be grouped into three categories: secure more external funding, identify public/private sponsorship opportunities, and raise local revenue through existing and/or new user fees and taxes. The City of Oakridge should consider developing a funding package using these options to identify additional funds to implement projects in the TSP and maintain multimodal facilities in the City. Several of the most promising local revenue sources for Oakridge include:

- ▶ Increasing the local fuel tax [currently \$0.03] (to cover maintenance and/or new capital improvement projects);
- ▶ Implementing a Street Utility Fee (to cover transportation maintenance need);
- ▶ Implementing System Development Charges (SDCs) (to cover new capital improvement projects); and
- ▶ Local Bond Measures (to cover sidewalks and other multimodal projects).

## 01 | TRANSPORTATION PRIORITIES AND EVALUATION CRITERIA

The TSP recommends transportation programs, studies, and infrastructure improvements to fulfill the plan's goals and policies.

Projects, studies and programs were assigned a relative priority based on the following factors:

- ▶ Results of the evaluation criteria assessment;
- ▶ Analysis and data driven needs as identified in Technical Memorandum #5;
- ▶ Input from the Advisory Committee, City, and ODOT; and
- ▶ Relative ease of implementation.

Based on the priority assessment, solutions were organized into three categories that suggest timeframes for implementation based on complexity, likely available funding (including potential funding sources), and assessment of need.

- ▶ High Priority – Short Term (Projects to be completed within 1-5 years);
- ▶ Medium Priority – Medium Term (Projects to be completed within 6-10 years);
- ▶ Low Priority – Long Term (Projects to be completed within 11-20 years);
- ▶ Vision (Projects to be completed beyond 20 years).

The TSP articulates policies and actions that explicitly prioritize facilities and improvements that support mobility and safety of all users. These priorities include improved convenience and safety for walking, biking, and connections to transit stops, updated roadway standards and access to key destinations such as the schools and the uptown area.

Inclusion of a project in the next 20-years or beyond 20 years does not represent commitment to complete the project during that timeframe. While the TSP prioritizes projects for implementation, the City may advance projects in a different manner than anticipated in the TSP to take advantage of unforeseen opportunities or changes in circumstances. These opportunities could include changes in policy or funding at the federal, state, or local level; changes in local development priorities; or the formation of public-private or public-public partnerships. The prioritization of projects identified as within 20 years are intended to be interpreted flexibly with those that are identified as vision projects to allow the City to make prudent investment decisions consistent with the overall vision contained in the 2040 TSP.



The projects described in these lists represent the best estimation for appropriate design available at time of TSP adoption. Since the TSP was drafted at a high-level citywide scale, project design may change before construction commences as public input, available funding, and unique site conditions are taken into consideration. In determining the appropriate amount of public involvement for a project, the City considers the scale, scope and potential impacts of the project. Prior to commencing a capital transportation project, the City staff should engage the community to help in refining the final constructed improvement.

## 02 | HISTORIC FUNDING OVERVIEW

The Oakridge TSP includes projects under the jurisdiction and ownership of ODOT, Lane County, the City of Oakridge, and Lane Transit District (LTD), as well as projects that may be implemented by private developers. Individual TSP projects will be funded through a combination of federal, state, City, county, and/or private sources.

Today's fiscal environment is beset by uncertainty about future federal, state and local funding for transportation projects. This uncertainty provides challenges to accurately forecast the amount of funding available for transportation investments, and what projects or programs will receive funding. The following section provides planning level cost estimates that include the City's estimated contribution cost. The funding partners indicate which agencies or organizations are anticipated to contribute to the cost of the project. To provide a match for federal and/or state funding opportunities, a 10-percent City contribution was assumed on all ODOT facility projects. Additionally, a 50-percent match was assumed on County projects in the City UGB. Public/private projects were fully accounted for as City contributions as fees may be captured by local revenue sources.

Potential funding sources were identified in Technical Memorandum #3: *Funding for Transportation System Improvements*. This memorandum discussed the current revenue and expenditures in the City's street fund and identified potential funding sources at the federal, state, and local level.

Table 1 shows the City has incurred approximately a \$10,000 deficit each year since 2013 simply to maintain existing roadways. This is shown by the average annual net income (excluding street improvements). When considering the funding the City applied towards street improvement projects, the City spent an average of \$72,000 per year more than the Street Fund achieved in revenue each year. Therefore, the City was able to complete the street improvement projects largely using funds that were saved from years prior to 2013.

Description	FY 2013-2014	FY 2014-2015	FY 2015-2016	FY 2016-2017	FY 2017-2018
Net Income: Revenue minus Expenses	\$(134,459)	\$(44,341)	\$(197,332)	\$14,726	\$(1,890)
Average Annual Net Income					\$(72,643)
Net Income (Excluding Street Improvements): Revenue minus Expenses	\$(33,675)	\$(36,302)	\$8,869	\$14,726	\$(1,890)
Average Annual Net Income (Excluding Street Improvements)					<b>\$(9,638)</b>

This funding gap indicates that the City needs to identify new funding sources to continue operating and maintaining its transportation facilities. If the spending trend were to continue without additional funding sources, the City Street Fund would last less than ten years for maintenance alone. Oakridge has relied upon its reserve funds to continue operating but needs to identify additional long-term reliable funding to remain sustainable. In addition to identifying funding sources for operations and maintenance, the City also lacks available funding to complete Citywide improvement projects. A new or enhanced existing funding source is necessary to establish a reliable, sustainable reserve and deliver identified investments in the TSP. This memorandum documents the funds needed to implement projects identified in the TSP and identifies potential funding sources.

## 03 | PLANNING LEVEL COST ESTIMATES

Costs for projects are provided in the subsequent tables. These costs are order-of-magnitude or planning-level estimates that include an estimate of right-of-way, design engineering and construction, and generally a 30 percent contingency.

All costs are rounded and provided in 2019 dollars. Each table includes a column called "safety benefit". This column shows the estimated safety benefit of the project based on the Crash Reduction Factor (CRF). A CRF is the percentage crash reduction that might be expected after implementing a given countermeasure. ODOT has developed a list of approved CRFs that allow projects to be evaluated consistently throughout the state<sup>1</sup>. The ODOT approved CRF is shown in the "safety benefit" column unless further specified. These are provided to help the City understand which projects provide strong safety benefits and may therefore be strong candidates for safety grant funds, particularly at locations with a documented crash history.

Vision projects, those that are currently not anticipated to be needed or implemented until after 20 years, are included in the project lists without cost estimates. Inclusion of projects in the beyond 20-year category provides the City flexibility to re-evaluate priorities and to pursue a variety of funding opportunities that may arise over the life of the TSP. Vision projects are identified at the bottom of tables where applicable.

### STREET SYSTEM SOLUTIONS

The projects shown in Tables 2 represents the City's draft priorities for implementation of street system solutions. Figure 1 provides a map of the roadway solutions listed in Table 2. These solutions are symbolized based on their priority. This includes freight, paving, and roadway projects. These projects are included to improve the overall roadway system in the City by providing new roadway connections, designating local freight routes, implementing pavement improvements, and improving or installing illumination. As identified in Technical Memorandum #4, no operational capacity issues are expected in the system within the planning horizon. Table 2 also provides project planning level cost estimates. These planning level cost estimates include right-of-way, clearing and grubbing, excavation, embankment, materials, mobilization, traffic control, professional architecture/engineering fees, construction management fees, and contingency fees.

**Table 2. Street System Solution Cost Estimates**

Proj. ID	Proj. Name	Project Description	Location	Safety Benefit (ODOT #)	Cost Estimate	Expected City Contribution	Funding Partners
<b>High Priority Projects</b>							
R-1	E 1st Street Uptown Corridor Refinement	Reconfigure E 1 <sup>st</sup> Street to include bike lanes on both sides and convert the existing angled parking to parallel parking on south side. Add bike lanes on E 1 <sup>st</sup> Street	E 1 <sup>st</sup> Street from Poplar Street to City limits	47% (BP20) <sup>3</sup>	\$1,293,0000	\$1,293,0000	

<sup>1</sup> ODOT Approved CFR list provided at <https://www.oregon.gov/ODOT/Engineering/Pages/ARTS.aspx>

**Table 2. Street System Solution Cost Estimates**

Proj. ID	Proj. Name	Project Description	Location	Safety Benefit (ODOT #)	Cost Estimate	Expected City Contribution	Funding Partners
		west of Hazel Street and restrict parking to one side of the road.					
R-6	OR 58 Street Reconfiguration Pilot Project	Implement a temporary lane reconfiguration on OR 58	OR 58 from Thatcher Lane to Jones Road	29%(H48)	\$75,000	\$8,000	ODOT
PV-1	City street paving program	Develop a citywide program to assess and maintain City streets of all classification	Citywide	6% <sup>1</sup> Identified in CMF Clearing-house	\$15,000	\$15,000	
PV-2	Industrial Park Way	Pave Industrial Park Way from Mill Pond to Fish Hatchery Road.	Industrial Park Way from Mill Pond to Fish Hatchery Road	75% <sup>2</sup> Identified in CMF Clearing-house	\$243,000	\$243,000	
PV-4	Berry Street	Repave Berry Street from Rainbow Street to the east	Berry Street from Rainbow Street to the east	6% <sup>1</sup> Identified in CMF Clearing-house	\$110,000	\$110,000	
<b>High Priority City Contribution Cost Total</b>						<b>\$1,669,000</b>	
<b>Medium Priority Projects</b>							
FR-1	Designated Local Freight Route	Provide a designated local freight route on Fish Hatchery Road, E 1 <sup>st</sup> Street, and Crestview Street. This includes pavement rehabilitation to accommodate truck loads.	Fish Hatchery Road, E 1 <sup>st</sup> Street, Crestview Street	N/A	\$1,354,000	\$677,000	County
R-4	Crestview Street Cross section and Multimodal Improvements	Improve the Crestview Street cross section to accommodate shared-use path on the east side by reducing travel lane widths.	Crestview Street from OR 58 to E 1 <sup>st</sup> Street	N/A	\$92,000	\$92,000	

**Table 2. Street System Solution Cost Estimates**

Proj. ID	Proj. Name	Project Description	Location	Safety Benefit (ODOT #)	Cost Estimate	Expected City Contribution	Funding Partners
R-5	OR 58 Illumination	Provide illumination along OR 58.	OR 58 from Hills Street to Hyland Lane	28% <sup>4</sup> (H26)	\$75,000	\$8,000	ODOT
PV-5	Jasper Drive	Repave Jasper Drive from Hills Street to the east	Jasper Drive from Hills Street to the east	6% <sup>1</sup> Identified in CMF Clearing-house	\$219,000	\$219,000	
PV-14	Beech Street	Repave Beech Street north of E 1 <sup>st</sup> Street	Beech Street north of E 1 <sup>st</sup> Street	6% <sup>1</sup> Identified in CMF Clearing-house	\$37,000	\$37,000	
PV-15	Cherry Street	Repave Cherry Street north of E 1 <sup>st</sup> Street	Cherry Street north of E 1 <sup>st</sup> Street	6% <sup>1</sup> Identified in CMF Clearing-house	\$37,000	\$37,000	
PV-16	Douglas Street	Repave Douglas Street north of E 1 <sup>st</sup> Street	Douglas Street north of E 1 <sup>st</sup> Street	6% <sup>1</sup> Identified in CMF Clearing-house	\$37,000	\$37,000	
PV-17	Elm Street	Repave Elm Street north of E 1 <sup>st</sup> Street	Elm Street north of E 1 <sup>st</sup> Street	6% <sup>1</sup> Identified in CMF Clearing-house	\$37,000	\$37,000	
<b>Medium Priority City Contribution Cost Total</b>						<b>\$1,144,000</b>	
<b>Low Priority Projects</b>							
FR-2	Weigh Station Feasibility Study	Conduct a feasibility study to identify the need and viability of a weigh station for heavy vehicles on the eastside of Oakridge using Oakridge's existing (inactive) weigh station.	Determined by study	N/A	\$50,000	\$50,000	
FR-3	Truck Parking Feasibility Study	Conduct a feasibility study to identify the need and viability of constructing a truck parking area for heavy	Determined by study	N/A	\$30,000	\$30,000	

**Table 2. Street System Solution Cost Estimates**

Proj. ID	Proj. Name	Project Description	Location	Safety Benefit (ODOT #)	Cost Estimate	Expected City Contribution	Funding Partners
		vehicles within Oakridge.					
FR-4	Commercial Truck Stop	Conduct a feasibility study to identify the need and viability of constructing a commercial truck stop center within Oakridge.	Determined by study	N/A	\$25,000	\$25,000	
R-2	Green-waters Park Illumination	Illuminate the intersection of OR 58/ Greenwaters Park and the parking lot.	Green-waters Park	28% <sup>4</sup> (H26)	\$115,00	\$115,000	
R-3	E 2 <sup>nd</sup> Street Road Closure	Close E 2 <sup>nd</sup> Street to eliminate the sight distance constraints at the skewed intersection of E 2 <sup>nd</sup> Street/Westoak Road.	E 2 <sup>nd</sup> Street between Westoak Road and Beech Street	48% (I10)	\$188,000	\$94,000	County
PV-3	Osprey Park parking lot	Pave both the River Road and Perkins Street parking areas to access Osprey Park.	Osprey Park (both River Road and Perkins Street parking areas)	N/A	\$114,000	\$114,000	
PV-6	Paddock Lane	Pave Paddock Lane from W 2 <sup>nd</sup> Street to Union Street	Paddock Lane from W 2 <sup>nd</sup> Street to Union Street	6% <sup>1</sup> Identified in CMF Clearing-house	\$110,000	\$110,000	
PV-7	Beaver Lane/Beaver Street	Repave the extents of Beaver Lane/Beaver Street	The extents of Beaver Lane/Beaver Street	6% <sup>1</sup> Identified in CMF Clearing-house	\$73,000	\$73,000	
PV-8	Hansen Street	Repave Hansen Street from River Road to Klonn Road	Hansen Street from River Road to Klonn Road	6% <sup>1</sup> Identified in CMF Clearing-house	\$91,000	\$91,000	
PV-9	Cline Street	Repave Cline Street from Klonn Road to Garden Road	Cline Street from Klonn Road to Garden Road	6% <sup>1</sup> Identified in CMF Clearing-house	\$88,000	\$88,000	

**Table 2. Street System Solution Cost Estimates**

Proj. ID	Proj. Name	Project Description	Location	Safety Benefit (ODOT #)	Cost Estimate	Expected City Contribution	Funding Partners
PV-10	Portal Drive	Repave Portal Drive north of W 2 <sup>nd</sup> Street	Portal Drive north of W 2 <sup>nd</sup> Street	6% <sup>1</sup> Identified in CMF Clearing-house	\$44,000	\$44,000	
PV-11	Riverview Street	Repave Riverview Street from Klonn Road to Garden Road	Riverview Street from Klonn Road to Garden Road	6% <sup>1</sup> Identified in CMF Clearing-house	\$101,000	\$101,000	
PV-12	Jones Road	Repave Jones Road from OR 58 to Elgin Avenue	Jones Road from OR 58 to Elgin Avenue	6% <sup>1</sup> Identified in CMF Clearing-house	\$77,000	\$77,000	
PV-13	Elgin Avenue	Repave Elgin Avenue from Rock Road to the east	Elgin Avenue from Rock Road to the east	6% <sup>1</sup> Identified in CMF Clearing-house	\$73,000	\$73,000	
<b>Low Priority City Contribution Cost Total</b>						<b>\$1,081,000</b>	
<b>Vision Projects</b>							
R-7	Long Term OR 58 Street Reconfiguration Project	Reconfigure the highway's cross section to accommodate one lane in each direction with multimodal facilities, based on results of pilot project.	OR 58	29%(H48)	N/A	N/A	ODOT

<sup>1</sup>“Resurface pavement” on cmfclearinghouse.org

<sup>2</sup>“Change roadway surface from gravel or dirt to asphalt” on cmfclearinghouse.org. Assumed 500 ADT

<sup>3</sup>Applies to bicycle related crashes

<sup>4</sup>Applied to nighttime crashes

H:\22\2477 - Oakridge TSP Update\GIS\Memo 5 - Alternatives\Prioritized Projects\01 Location and Priority of Street System Solutions.mxd - jgulczynski - 2:20 PM 6/21/2019

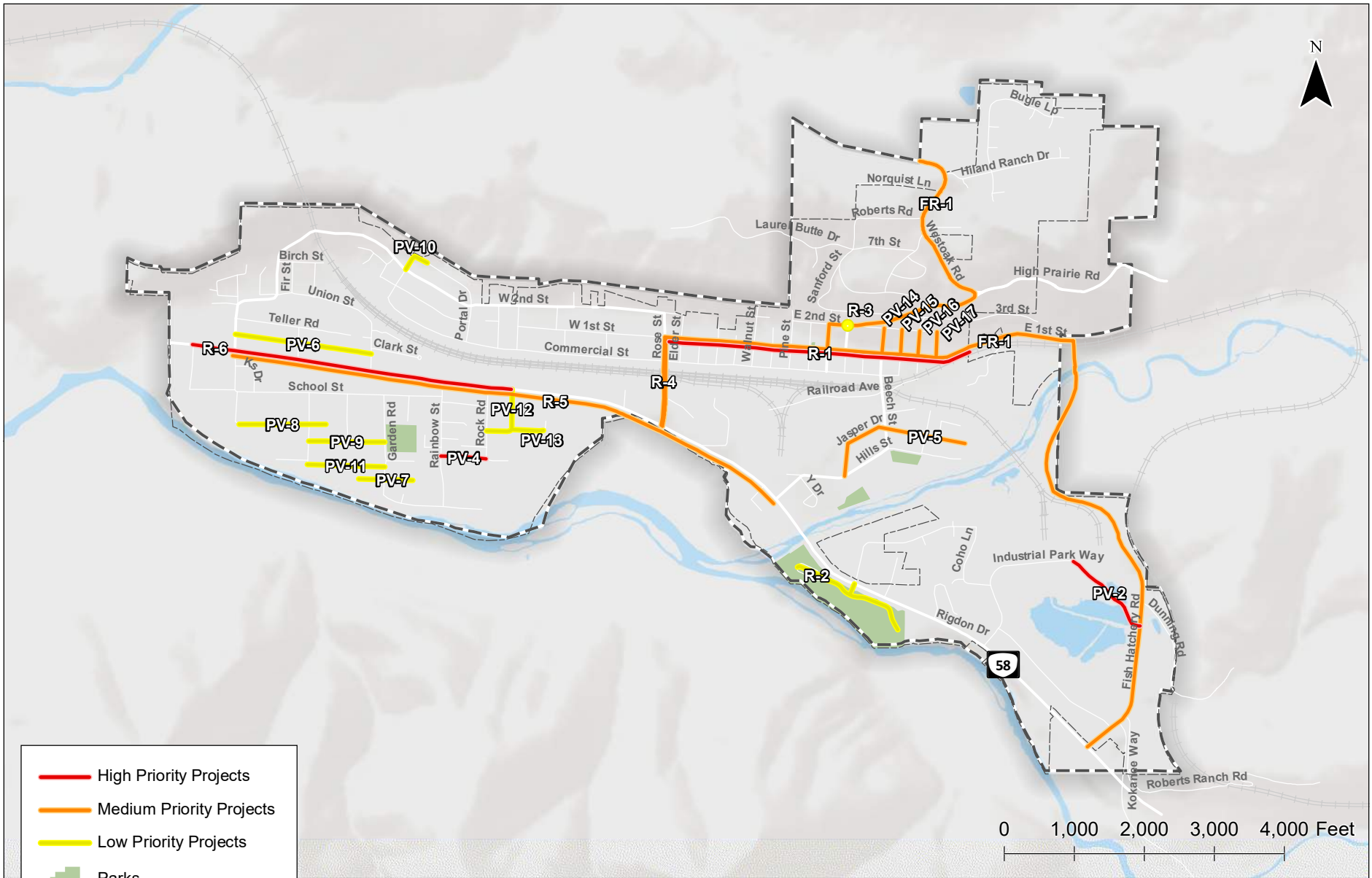

- High Priority Projects
- Medium Priority Projects
- Low Priority Projects
- Parks
- Oakridge City Boundary
- Urban Growth Boundary

**Location and Priority of Street System Solutions  
Oakridge, Oregon**

**Figure  
1**

Table 3 provides an overview of the street system projects by city contribution cost and priority. The majority of the projects are medium, low, or vision projects. The high priority projects do not exceed \$500,000. There are several high cost medium priority projects including upgrading the roadways to accommodate the local freight route and the E 1<sup>st</sup> Street paving project.

<b>Table 3. Street System Solutions City Cost Summary</b>			
<b>High Priority</b>	<b>Medium Priority</b>	<b>Low Priority</b>	<b>Total</b>
\$1,669,000	\$1,144,000	\$1,081,000	\$3,894,000



## SAFETY SOLUTIONS

Table 4 presents the safety solutions that were developed to address identified safety needs. Safety needs were determined through crash data, and input from the public, Advisory Committee, and City staff to understand perceived safety concerns. Technical Memorandum #4 provides a summary of crash data from the most recent 5-year period. Figure 2 shows the location and priority of safety solutions.

**Table 4. Safety Solution Cost Estimates**

Proj. ID	Proj. Name	Project Description	Location	Safety Benefit (ODOT #)	Cost Estimate	Expected City Contribution	Funding Partner
<b>High Priority Projects</b>							
S-3	Intersection safety improvement at OR 58/Industrial Park Way	Move merge lane west and develop eastbound left turn lane into the industrial park.	OR 58/Industrial Park Way Intersection	33% (H7)	\$23,000	\$2,000	ODOT
S-5	Speed feedback signs entering Oakridge (east and west)	Install speed feedback signs in conjunction with posted speed limit signs.	East and West approaches of OR 58 to Oakridge	41% (H47)	\$30,000	\$3,000	ODOT
<b>High Project City Contribution Cost Total</b>						<b>\$5,000</b>	
<b>Medium Priority Projects</b>							
S-1	Systemic safety intersection improvements on OR 58	Provide/upgrade intersection warning signs, install or widen centerlines/edge lines, improve side street intersection visibility (signage, striping, recessed pavement markers).	Locations on OR 58 include, but are not limited to, Hills Street, Union Street, River Road, Rainbow Road, Hyland Lane	30%(I12)	\$17,000	\$2,000	ODOT
S-4	Intersection safety improvement at Crestview Street/E 1st Street	Reconfigure the intersection to slow vehicle speed through the intersection.	Crestview Street/E 1st Street Intersection	75% (H18)	\$21,000	\$21,000	
<b>Medium Project City Contribution Cost Total</b>						<b>\$23,000</b>	
<b>Vision Projects</b>							
S-2	Intersection safety improvement at High Prairie Road/West oak Road	Upgrade signing, sight distance improvements (including roadway realignment), curve warning and intersection warning	High Prairie Road/West oak Road Intersection	48% (I10)	N/A	N/A	County

H:\22\2477 - Oakridge TSP Update\GIS\Memo 5 - Alternatives\Prioritized Projects\02 Location and Priority of Safety Solutions.mxd - igulczynski - 2:29 PM 6/21/2019

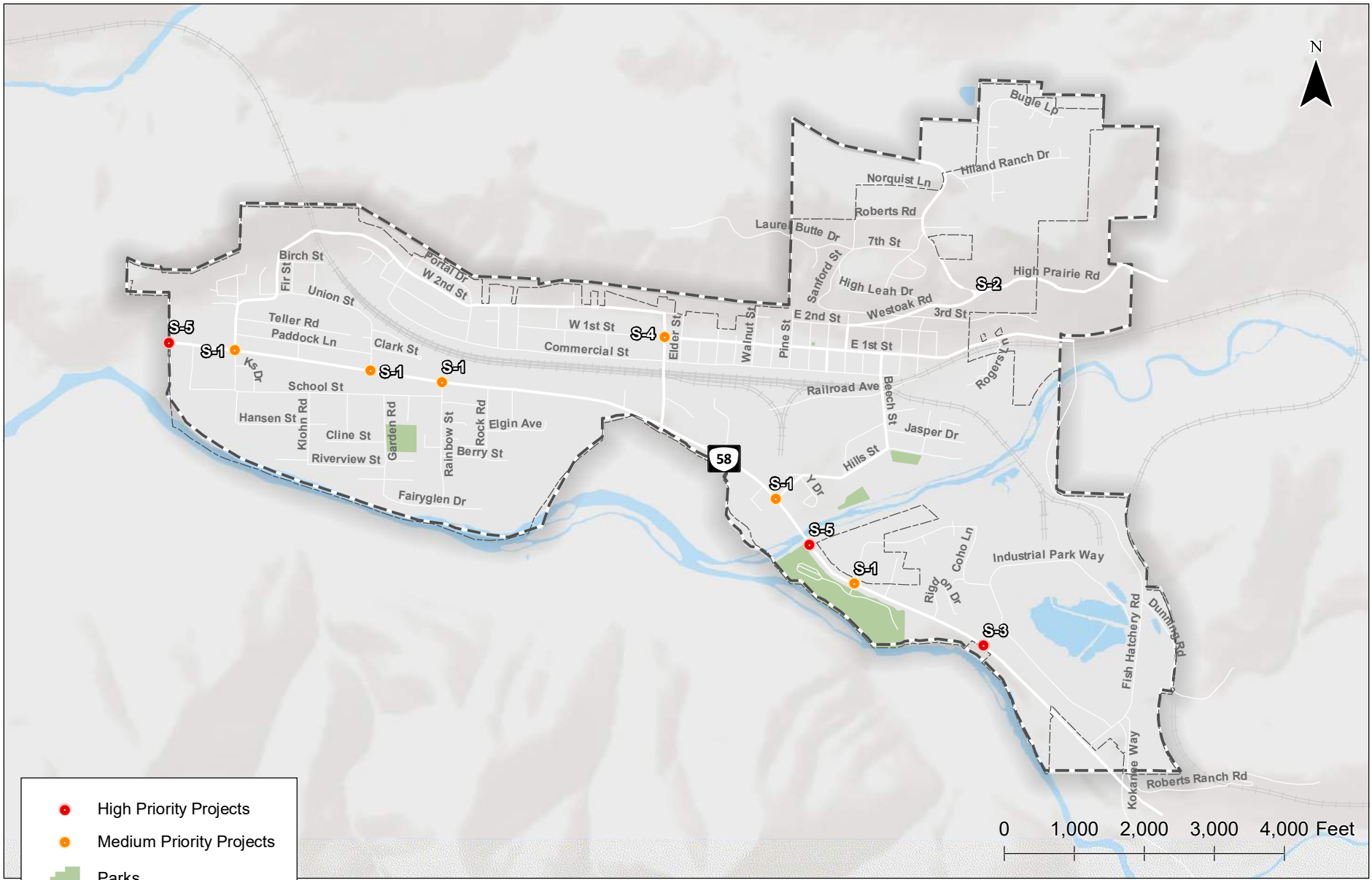

- High Priority Projects
- Medium Priority Projects
- Parks
- Oakridge City Boundary
- Urban Growth Boundary

**Location and Priority of Safety Solutions  
Oakridge, Oregon**

**Figure  
2**

Table 5 provides an overview of the safety solutions by cost and priority. As shown, the safety solutions have relatively low implementation costs. The OR 58/Industrial Way intersection improvement was the only safety project that was identified as a high priority.

**Table 5. Safety Solutions Cost Summary**

High Priority	Medium Priority	Low Priority	Total
\$5,000	\$23,000	N/A	\$28,000

## PEDESTRIAN SYSTEM SOLUTIONS

Table 6 identifies the pedestrian system solutions developed to address sidewalk, shared-use paths, and crosswalk facility needs within the City. The recommended solutions are primarily composed of sidewalk and shared-use path routes to complete pedestrian routes on the arterial and collector street systems as well as provide critical path connections on the local street and trail system. Figure 3 shows the location and priority of pedestrian solution projects.

**Table 6. Pedestrian System Solution Cost Estimates**

Proj ID*	Proj. Name	Project Description	Location	Safety Benefit (ODOT #)	Cost Estimate	Expected City Contribution	Funding Partners
<b>High Priority Projects</b>							
P-2	W 1st Street sidewalk	Fill in sidewalk gaps on both sides of W 1st Street	W 1 <sup>st</sup> Street between High Street and Poplar Street	88% <sup>1</sup> FHWA study	\$330,000	\$330,000	
P-3	OR 58 sidewalks	Construct sidewalks (both sides) or a multiuse path on the highway	OR 58 from Thatcher Lane to Fish Hatchery Road	88% <sup>1</sup> FHWA study	\$8,465,000	\$847,000	ODOT
P-9	Traffic Signal Pedestrian Improvement at Crestview/OR 58	Provide intersection lighting, pedestrian countdown timers for crossing of north leg, sidewalk infill on west side of north leg.	OR 58/Crestview Street intersection	70% <sup>2</sup> (BP1)	\$200,000	\$20,000	ODOT
P-10	Sidewalk and Pedestrian Ramp Program	Develop program to assess condition and ADA compliance of existing sidewalks and pedestrian ramps.	Determined by study	N/A	\$15,000	\$15,000	
C-4	OR 58/River Road-Thatcher	Install enhanced	On OR 58, approximately	37% <sup>2</sup> (BP12)	\$200,000	\$20,000	ODOT

**Table 6. Pedestrian System Solution Cost Estimates**

Proj ID*	Proj. Name	Project Description	Location	Safety Benefit (ODOT #)	Cost Estimate	Expected City Contribution	Funding Partners
	Lane Pedestrian Safety Improvement	pedestrian crossing which could include raised median, curb extension, traffic calming, illumination, etc.	350 feet east of Thatcher Lane				
C-5	OR 58/Rainbow Road Pedestrian Safety Improvement	Install enhanced pedestrian crossing which could include raised median, curb extension, traffic calming, illumination, etc.	On OR 58, approximately 40 feet east of Rainbow Road	37% <sup>2</sup> (BP12)	\$200,000	\$20,000	ODOT
SU-2	Fish Hatchery Road Multiuse Path	Construct a multiuse path along Fish Hatchery Road.	Fish Hatchery Road from OR 58 to the existing sidewalk on E 1 <sup>st</sup> Street	88% <sup>1</sup> FHWA study	\$2,105,000	\$1,053,000	County
<b>High Priority City Contribution Cost Total</b>						<b>\$2,912,000</b>	
<b>Medium Priority Projects</b>							
P-7	W 2nd Street sidewalk	Construct sidewalk on W 2nd Street	W 2 <sup>nd</sup> Street from Commercial Street to E Portal Drive	88% <sup>1</sup> FHWA study	\$245,000	\$245,000	
C-2	Feasibility study for grade separated railroad crossing at Union Street and Commercial Street	Evaluate the feasibility of building a grade-separated crossing of the railroad tracks.	Railroad crossing between Union Street and Commercial Street approximately a quarter-mile east of W 2 <sup>nd</sup> Street	13% <sup>3</sup> FHWA study	\$25,000	\$25,000	
C-6	OR 58/Hill Street Pedestrian Safety Improvement	Install enhanced pedestrian crossing which could include raised median, curb extension, traffic calming, illumination, etc..	On OR 58, approximately 20 feet east of Hills Street	37% <sup>2</sup> (BP12)	\$200,000	\$20,000	ODOT
C-7	OR 58/Union Street Pedestrian Safety Improvement	Install enhanced pedestrian crossing which could include	On OR 58, approximately 20 feet east of Union Street	37% <sup>2</sup> (BP12)	\$200,000	\$20,000	ODOT

**Table 6. Pedestrian System Solution Cost Estimates**

Proj ID*	Proj. Name	Project Description	Location	Safety Benefit (ODOT #)	Cost Estimate	Expected City Contribution	Funding Partners
		raised median, curb extension, traffic calming, illumination, etc.					
SU-1	Westoak Road Multiuse Path	Construct a multiuse path on the north side of Westoak Road.	Westoak Road from Oak Street to the City limits	88% <sup>1</sup> FHWA study	\$1,331,000	\$666,000	County
SU-3	Industrial Park Way Multiuse Path	Construct a multiuse path on the north side of Industrial Park Way	Industrial Park Way from OR 58 to Fish Hatchery Road	88% <sup>1</sup> FHWA study	\$1,254,000	\$1,254,000	
<b>Medium Project City Contribution Cost Total</b>						<b>\$1,416,000</b>	
<b>Low Priority Projects</b>							
P-4	River Road sidewalk	Construct sidewalk on west side of River Road	River Road from OR 58 to School Street	88% <sup>1</sup> FHWA study	\$210,000	\$210,000	
P-5	W 2nd Street sidewalk	Construct sidewalk on the west side of W 2nd Street	W 2 <sup>nd</sup> Street from OR 58 to approximately 150 feet north of Teller Road	88% <sup>1</sup> FHWA study	\$200,000	\$200,000	
P-6	W 2nd Street sidewalk improvement	Widen existing sidewalk on northwest side of W 2nd Street	W 2 <sup>nd</sup> Street from Teller Road to Commercial Street	N/A	\$460,000	\$460,000	
P-8	Local street sidewalk program	A citywide program to improve the local street sidewalk network throughout the City	Citywide	88% <sup>1</sup> FHWA study	\$5,030,000	\$5,030,000	
C-1	Marked Pedestrian Crossings	Install marked crosswalks on arterials and collectors where sidewalks are present.	See Figure 3 for locations	48% <sup>3</sup> FHWA study	\$10,000	\$10,000	
C-3	Beech Street rail crossing improvements	Install pedestrian and cyclist improvement at grade railroad crossing	Beech Street rail crossing	88% <sup>1</sup> FHWA study	\$180,000	\$180,000	Rail

**Table 6. Pedestrian System Solution Cost Estimates**

Proj ID*	Proj. Name	Project Description	Location	Safety Benefit (ODOT #)	Cost Estimate	Expected City Contribution	Funding Partners
SU-4	High Prairie Road Multiuse Path	Construct a multiuse path on the north side of High Prairie Road	High Prairie Road from Westoak Road to City limits	88% <sup>1</sup> FHWA study	\$846,000	\$423,000	County
SU-5	Garden Road, Fairyglen Drive, Rainbow Street Multiuse Path	Construct a multiuse on Garden Road, Fairyglen Drive, Rainbow Street	South of the Willamette Activity Center on Garden Road to Fairyglen Drive and Rainbow Street to the sidewalk connection	88% <sup>1</sup> FHWA study	\$777,000	\$777,000	
SU-7	West Oakridge Trail Bridge Feasibility Study	Construct a bridge crossing from Osprey Park south of the Willamette River and connect to the existing trail system	Across the Willamette River near Osprey Park	N/A	\$75,000	\$75,000	
SU-8	Union Street Multiuse Path	Construct a multiuse path on the north/east side of Union Street	Union Street from OR 58 to W 2 <sup>nd</sup> Street	88% <sup>1</sup> FHWA study	\$598,000	\$598,000	
<b>Low Priority City Contribution Cost Total</b>						<b>\$9,539,000</b>	
<b>Vision Project</b>							
SU-6	Salmon Creek Trail Bridge Feasibility Study	Conduct a study to identify the feasibility of a bridge crossing between the parallel Salmon Creek trails.	Across the Salmon Creek near OR 58	N/A	N/A	N/A	

\*P-1 removed based on comments received by the PAC. Projects will be renumbered as part of the TSP

<sup>1</sup> From FHWA study: *An Analysis of Factors Contributing to "Walking Along Roadway" Crashes: Research Study and Guidelines for Sidewalks and Walkways (FHWA-RD-01-101)*. Applies to pedestrian related crashes

<sup>2</sup> Applies to pedestrian related crashes

<sup>3</sup> From FHWA study: *"Toolbox of Countermeasures and Their Potential Effectiveness"* FHWA-SA-018-41. Applies to all crash types.

H:\22\2477 - Oakridge TSP Update\GIS\Memo 5 - Alternatives\Prioritized Projects\03 Location and Priority of Pedestrian System Solutions.mxd - jguczynski - 4:12 PM 7/11/2019

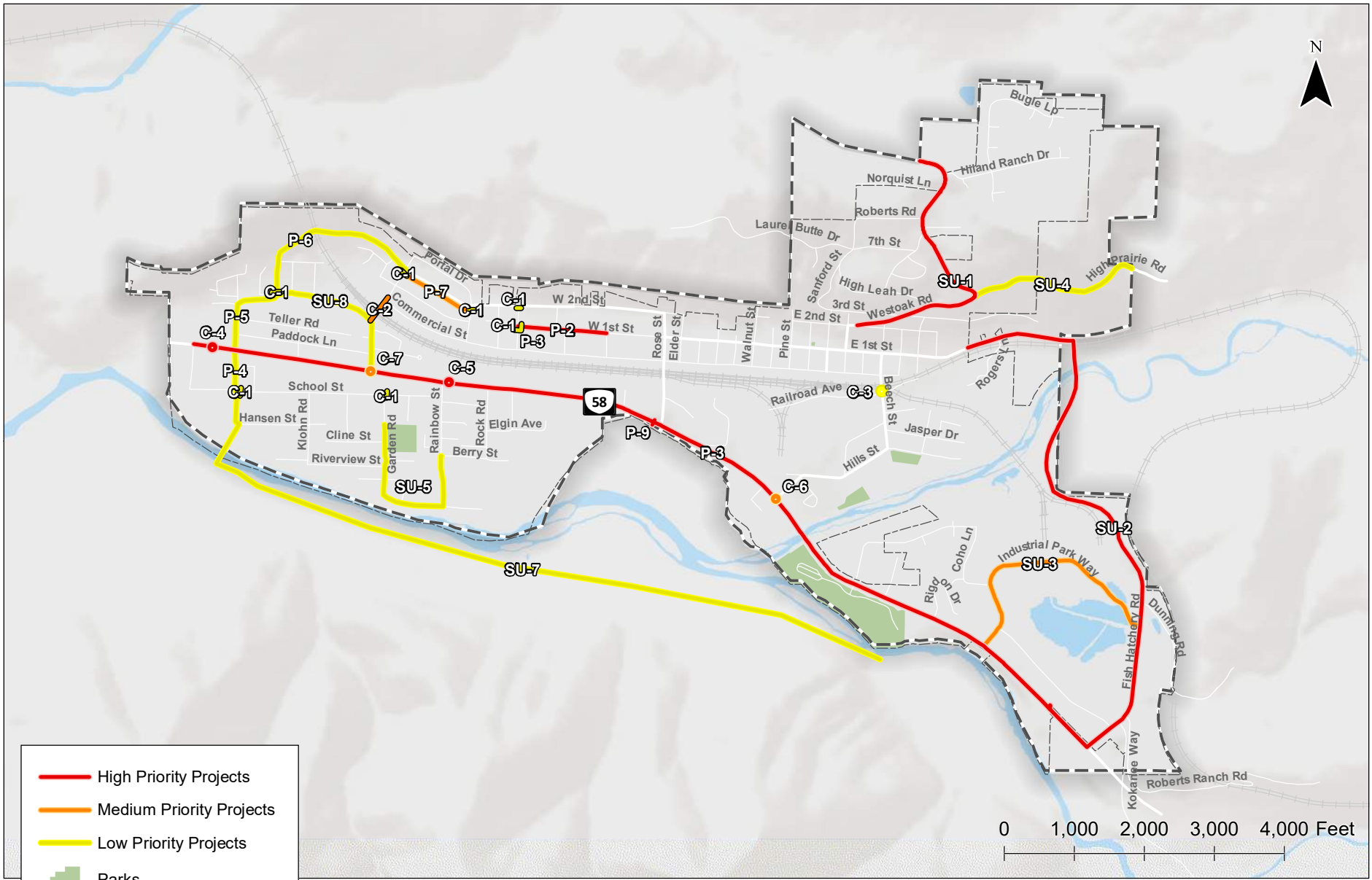

**Location and Priority of Pedestrian System Solutions  
Oakridge, Oregon**

**Figure  
3**

Table 7 shows the pedestrian system cost summary based on priority. The high priority cost estimate is considerably higher than other categories. This is primarily caused by the high cost of sidewalk installation on OR 58 and the shared-use paths on Fish Hatchery Road and Industrial Park Road.

**Table 7. Pedestrian System Solutions Cost Summary**

High Priority	Medium Priority	Low Priority	Total
\$2,912,000	\$1,416,000	\$9,539,000	\$13,867,000

## BICYCLE SYSTEM SOLUTIONS

Table 8 provides a cost estimate of the bicycle system solutions categorized by priority. Most bicycle solutions are associated with filling gaps in the bicycle network. Figure 4 labels the bicycle solutions based on priority. Table 9 shows an overview of the bicycle solutions by cost and priority.

**Table 8. Bicycle System Solution Cost Estimates**

Proj. ID	Proj. Name	Project Description	Location	Safety Benefit (ODOT #)	Cost Estimate	Expected City Contribution	Funding Partners
<b>High Priority Projects</b>							
B-3	E 1 <sup>st</sup> Street bicycle lanes	Stripe bicycle lanes on E 1 <sup>st</sup> Street. May require removing on-street parking.	Poplar Street to City Limits	36% <sup>1</sup> (BP18)	\$80,000	\$80,000	
B-6	OR 58 bicycle lanes	Sign, stripe and widen for bicycle lanes along OR 58 <sup>^</sup>	OR 58 from Thatcher Lane to Fish Hatchery Road	47% <sup>1</sup> (BP18)	\$9,580,000	\$958,000	ODOT
B-7	Bicycle support hub	Construct a bicycle hub, or "rest stop," for hikers, bicyclists, recreationalists, and community members.	This should be coordinated with potential sponsors for cost purposes and with partnering agencies to identify the best location	N/A	\$30,000	\$30,000	Private
B-8	Citywide bicycle signage program	Provide bicycle signage throughout the community directing cyclists to the Citywide bicycle network and to nearby trails.	Throughout the community on key bicycle routes	N/A	\$20,000	\$20,000	
<b>High Priority Cost Total</b>						<b>\$1,088,000</b>	
<b>Medium Priority Projects</b>							
B-1	W 2nd Street bicycle lanes	Stripe bicycle lanes on W 2nd Street	W 2nd Street from OR 58 to E Portal Drive	36% <sup>1</sup> (BP18)	\$68,000	\$68,000	



**Table 8. Bicycle System Solution Cost Estimates**

Proj. ID	Proj. Name	Project Description	Location	Safety Benefit (ODOT #)	Cost Estimate	Expected City Contribution	Funding Partners
B-4	Hills Street/Beech Street bicycle lanes	Stripe bicycle lanes on Hills Street/Beech Street	Hill Street/Beech Street from OR 58 to E 1st Street	36% <sup>1</sup> (BP18)	\$33,000	\$33,000	
<b>Medium Priority City Contribution Cost Total</b>						<b>\$101,000</b>	
<b>Low Priority Projects</b>							
B-2	Commercial Street bicycle lanes	Widen the road and stripe bicycle lanes on Commercial Street	Commercial Street from W 2nd Street to Beech Street	36% <sup>1</sup> (BP18)	\$49,000	\$49,000	
B-5	School Street and Rivers Road bicycle lanes	Widen the road and stripe bicycle lanes on School Street and Rivers Road	Rivers Road: OR 58 to School Street; School Street: Rivers Road to Rainbow Road	36% <sup>1</sup> (BP18)	\$2,155,000	\$2,155,000	
B-9	Trail connection study	Complete study to identify bike facility connections to trail network	Determined by study	N/A	\$75,000	\$75,000	
<b>Low Priority City Contribution Cost Total</b>						<b>\$2,279,000</b>	

<sup>1</sup>This cost estimate does not include a roadway reconfiguration

<sup>1</sup>Applies to bicycle related crashes

H:\22\2477 - Oakridge TSP Update\GIS\Memo 5 - Alternatives\Prioritized Projects\04 Location and Priority of Bicycle System Solutions.mxd - 5:24 PM 6/21/2019

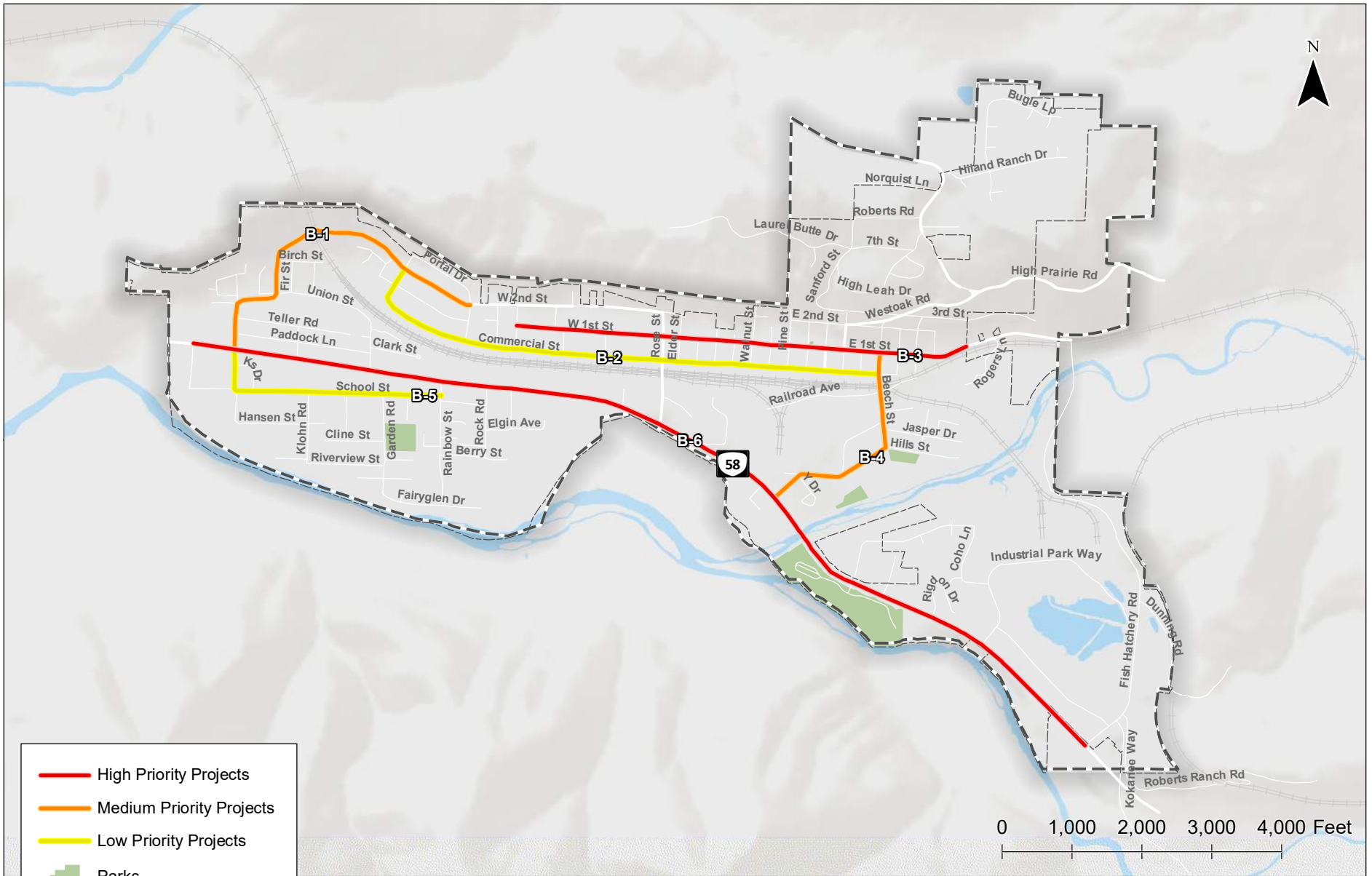

- High Priority Projects
- Medium Priority Projects
- Low Priority Projects
- + Parks
- Oakridge City Boundary
- Urban Growth Boundary

**Location and Priority of Bicycle System Solutions  
Oakridge, Oregon**

**Figure  
4**

**Table 9. Bicycle Solutions Cost Summary**

High Priority	Medium Priority	Low Priority	Total
\$1,088,000	\$101,000	\$2,279,000	\$3,468,000

## TRANSIT, RAIL, AND AIR SYSTEM SOLUTIONS

Table 10 identifies the transit, rail, and air system solutions developed by the project team, Advisory Committee, City, and previous TSP. As shown, the majority of the projects listed below are feasibility studies that would require additional information to scope implementation projects. Figure 5 shows the location and priority of transit and rail projects.

**Table 10. Transit, Rail, Air System Solution Cost Estimates**

Proj. ID	Proj. Name	Project Description	Cost Estimate	Expected City Contribution	Funding Partner
<b>High Priority Projects</b>					
T-1	Community Dial-A-Ride	Provide accessibility for residents, particularly seniors and those with disabilities, through a dial-a-ride service that operates seven-days per week.	\$275,000/year <sup>1</sup>	\$138,000/year	LTD
<b>Medium Priority Projects</b>					
T-2	Feasibility study for fixed route service within Oakridge	Conduct a feasibility study to evaluate the ability to provide fixed route service (operating five-days per week) within Oakridge.	\$100,000	\$100,000	
T-3	Feasibility study to improve existing Diamond Express LTD route	Conduct a transit feasibility study with support from LTD and the City. Consider a near-term pilot program of limited Diamond Express operations on weekends.	\$25,000	\$25,000	LTD
RL-4	Rogers Lane crossing upgrade	Upgrade Rogers Lane to a public crossing. This will require coordination with Union Pacific and may require signalization.	\$50,000	\$50,000	

**Table 10. Transit, Rail, Air System Solution Cost Estimates**

Proj. ID	Proj. Name	Project Description	Cost Estimate	Expected City Contribution	Funding Partner
<b>Medium Priority City Contribution Cost Total</b>				<b>\$175,000</b>	
<b>Low Priority Projects</b>					
T-4	Transit community outreach	Educate the community about connections available within Oakridge to reach key destinations such as Eugene and Springfield.	\$80,000	\$80,000	
RL-1	Industrial Park Rail Spur Feasibility Study	Conduct a study to determine a viable future use of the existing railroad spur located in the Industrial Park	\$25,000	\$25,000	
RL-2	Conduct a quiet zone feasibility study	Conduct a quiet zone study for the railroad to identify measures to reduce noise.	\$25,000	\$25,000	
RL-3	Conduct an Amtrak passenger rail study	Conduct a feasibility study to identify the demand, desire, and funding needed to provide an Amtrak passenger rail stop in Oakridge	\$50,000	\$50,000	
RL-5	Swank Lane roadway upgrade	Construct Swank Lane as an alternative route to land between the rail line and Salmon Creek. This would serve as an alternative to upgrading the Rogers Lane crossing (RL-4).	\$974,000	\$974,000	
A-1	Protect and maintain the Oakridge State Airport	Adopt a policy to preserve and maintain the Oakridge State Airport	N/A	N/A	
<b>Low Priority City Contribution Cost Total</b>				<b>\$1,154,000</b>	

<sup>1</sup>Cost includes staff and route/vehicle maintenance. This does NOT include the cost of a vehicle.

<sup>2</sup>Cost over 20 year period. Approximately \$4,000 per year

Table 11 summarizes the cost and prioritization of the transit, rail, and air system solutions. Development of a Community Dial-A-Ride service is the only high priority project identified in this category.

**Table 11. Transit, Rail, and Air Solutions Cost Summary**

High Priority	Medium Priority	Low Priority	Total
\$138,000	\$175,000	\$1,154,000	\$1,467,000

H:\22\2477 - Oakridge TSP Update\GIS\Memo 5 - Alternatives\Prioritized Projects\05 Location and Priority of Transit and Rail System Solution.mxd - igulczynski - 4:16 PM 7/11/2019

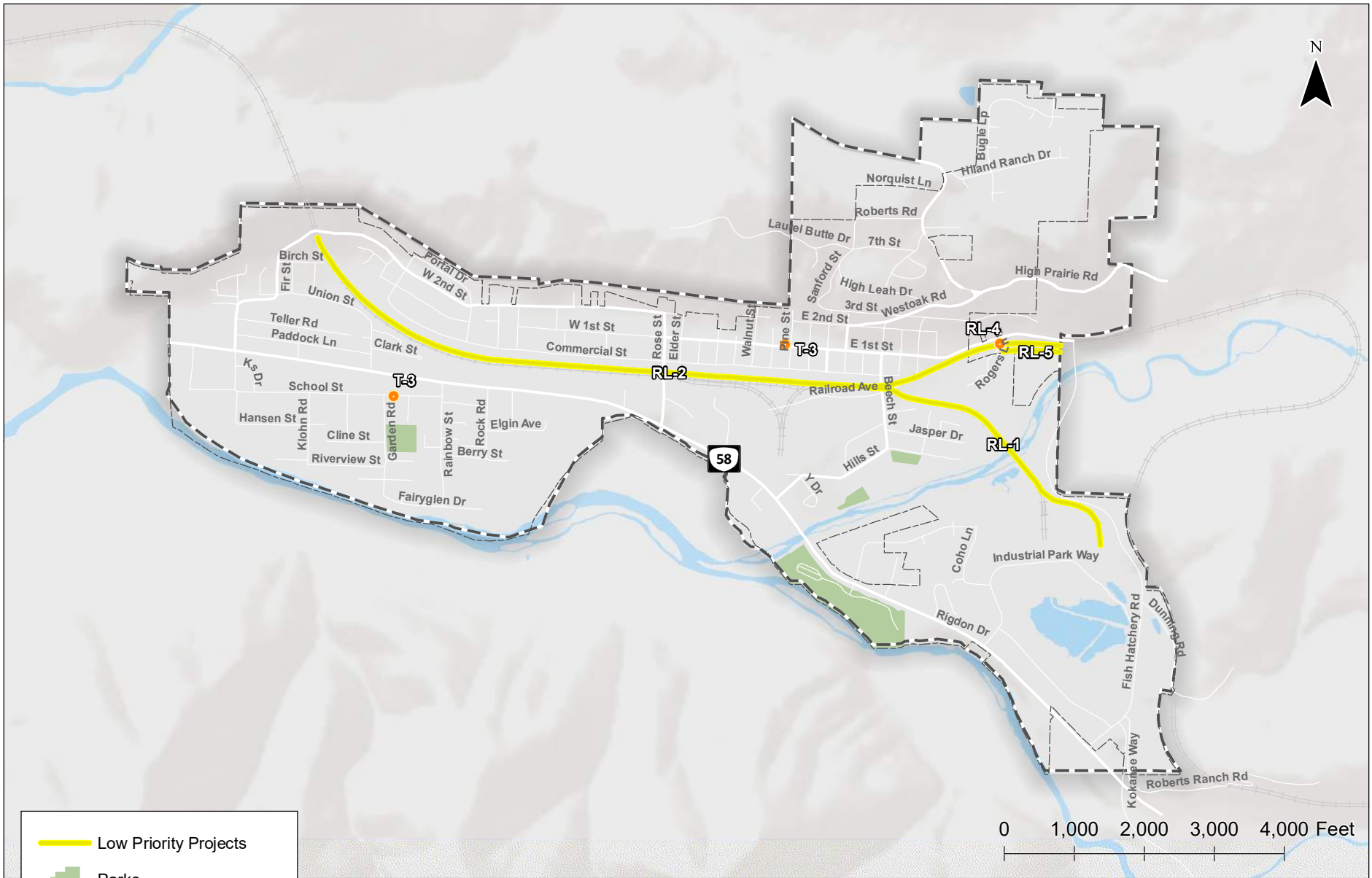

- Low Priority Projects
- Parks
- Oakridge City Boundary
- Urban Growth Boundary

**Location and Priority of Transit and Rail System Solutions  
Oakridge, Oregon**

**Figure  
5**

## IMPLEMENTATION SOLUTIONS

Section 4 below describes potential funding sources to improve and maintain the transportation infrastructure in Oakridge. To establish local revenues, potential funding sources have been identified in Section 4. Two of the recommended local revenue sources include System Development Charges (SDCs) and a Street Utility Fee. Studies should be conducted for both fee structures to develop a mechanism for funds based on development and land use. Table 12 shows a cost estimate for conducting both studies. Additionally, SDC rate studies are typically reimbursable when revenue from SDCs comes in, meaning the City could be reimbursed for performing this study.

**Table 12. Implementation System Solution Cost Estimates**

Proj. ID	Proj. Name	Project Description	Cost Estimate	Expected City Contribution	Funding Partner
<b>High Priority Projects</b>					
I-1	SDC Rate Development Study	A study that identifies how to divide the costs of projects and establishes a fee for developments.	\$35,000	\$35,000	
I-2	Street Utility Rate Development Study	A study to identify land uses and fees for owners based on the relative to the number of trips	\$35,000	\$35,000	
<b>High Priority City Contribution Cost Total</b>				<b>\$70,000</b>	

## 04 | FUTURE TRANSPORTATION FUNDING PLAN

The City of Oakridge faces issues of how to finance operations, maintenance, and capital improvement projects. To accomplish all the projects identified above, the City would need approximately \$23 million. Table 13 provides a summary of the costs associated with high, medium, and low priority projects. Table 13 shows a funding break down according to priority and project type. The total funding needed to accomplish all of the high priority solutions summarized in this plan would be approximately \$6 million over the next 5-year period.

Potential strategies for addressing the funding gap in Oakridge may generally be grouped into three categories: secure more external funding, identify public/private sponsorship opportunities, and raise local revenue through user fees and taxes. Observations on the use of these strategies are discussed below. They are not all mutually exclusive.

**Table 13. Cost Summaries by Priority and Project Type**

Project Type	High Priority	Medium Priority	Low Priority	Total
Street System	\$1,669,000	\$1,144,000	\$1,081,000	\$3,894,000
Safety	\$5,000	\$23,000	N/A	\$28,000
Pedestrian System	\$2,912,000	\$1,416,000	\$9,539,000	\$13,867,000
Bicycle	\$1,088,000	\$101,000	\$2,279,000	\$3,468,000
Transit, Rail, & Air	\$138,000	\$175,000	\$1,154,000	\$1,467,000
Implementation	\$70,000	N/A	N/A	\$70,000
<b>Total</b>	<b>\$5,882,000</b>	<b>\$2,859,000</b>	<b>\$14,053,000</b>	<b>\$22,794,000</b>

## Identify Additional Grant Opportunities

ODOT offers multiple grant opportunities to support transportation projects. Some of these programs require a local match. The City should begin identifying these programs early in order to plan for the funding necessary to satisfy a local match. Using local dollars as a match for a grant opportunity is a strategy to stretch the local funding even farther. Table 14 provides a list of potential federal, state, and county funding sources.

Table 14. Current and Potential Agency Funding Source Summary			
Funding Sources	Intended User	Currently Used By the City of Oakridge?	Near Term Recommend Grants to Apply for:
<b>Federal Sources</b>			
FAST Act	Dedicates funding to road, bridge, bicycling, and pedestrian improvements		✓
Surface Transportation Program/ Surface Transportation Block Grant	Preserves and improves surface transportation investments from a flexible funding source		
Congestion Mitigation and Air Quality (CMAQ)	Dedicates funding to projects that help eliminate CO2 emissions		✓
Highway Safety Improvement Program	A safety program to provide improvements to areas in need of safety improvements		✓
Federal Lands Access Program (FLAP)	Provides funding to facilities that provide access to, are adjacent to, or are located within Federal lands.		✓
<b>State Sources</b>			
State Highway Fund	Makes construction, maintenance, and operations improvements on roads and highways	✓	
Keep Oregon Moving (HB 2017)	Creates a steady funding stream for statewide transportation improvements	✓	
All Roads Transportation Safety	Uses limited funds to make the highest-impact safety improvements on roads and highways		✓
Connect Oregon	Invests in a multimodal transportation system across Oregon		
Statewide Transportation Improvement Program	Establishes multi-year, statewide, intermodal program of transportation projects to fund		✓
Safe Routes to School	Focuses on infrastructure and non-infrastructure programs to improve access and safety for children to walk or bike to school		✓
<b>County Sources</b>			
Lane County Road Fund	Funds dedicated to upgrading county roads within the right-of-way		
Urban Growth Management Agreement	Sets rules for how jurisdictions will manage transportation infrastructure non-		



**Table 14. Current and Potential Agency Funding Source Summary**

Funding Sources	Intended User	Currently Used By the City of Oakridge?	Near Term Recommend Grants to Apply for:
	urbanized land inside an Urban Growth Boundary		
Payroll Tax	The LTD provides the Diamond Express route through Oakridge		✓

### Public/Private Sponsorship Opportunities

Public/private sponsorships involve a private entity such as a local business owner working with the public agency to fund a project. In return for their investment in the community, these business owners often have recognition for their role, providing a marketing venue for the business. In Oakridge, one potential opportunity for this type of partnership is the project for bicycle support hub. Private organizations that sponsor a rest area should have the opportunity to provide an advertisement and map at these locations directing cyclists to their community and business.

### Local Taxes and User Fees

Many types of user fees and taxes may be collected to finance road construction and operations. On that premise, it is assumed that the City will need to develop local revenue sources to supplement or replace federal resources if it hopes to maintain current levels of service. It is also assumed that changes in state of federal financing, coupled with efficiency measures are not enough to close the funding gap. Table 15 lists potential local revenue sources along with recommended priority sources for Oakridge to consider. The sources include a mix of fees and taxes, some of which if implemented would have implications for other aspects of the City budgets. Some of these fees could also be used to provide a local match to obtain greater federal or state funding, further stretching local dollars.

One such potential funding opportunity for the City is increasing the local fuel tax. Currently, the City generates \$0.03 per gallon on fuel purchases. This results in approximately \$60,000 of annual revenue for the City. Increasing the local fuel tax by \$0.05 could generate an additional \$100,000 in annual revenue. This would enable the City to direct those funds to capital improvement projects or a federal or state matches.

**Table 15. Current and Potential Local Funding Source Summary**

Funding Sources	Intended User	Currently Used By the City of Oakridge?	Recommended for Consideration by Oakridge
Local Fuel Tax	Apply local fuel tax and use revenues to fund capital transportation improvements	✓	✓ (Increase In Tax)
System Development Charges (SDC)	Uses money from local development projects to fund capital transportation improvements		✓
Economic Improvement Districts (EID)	Pools funds from area businesses to make improvements in the business district.		
Local Improvement Districts (LID)	Pools funds from property owners to make local transportation improvements		
Urban Renewal Districts/Tax Increment Financing	Raises revenue from increased property values in an area to fund localized improvements		
General Fund (GF) Revenues	Setting aside General Fund revenues for transportation		
Local Bond Measures	Asks voters for bond funding to finance a set list of infrastructure investments		✓
Street Utility Fees/Road Maintenance Fee	Calculates trips generated for land uses and charges owners a fee relative to the number of trips		✓
Optional Tax	Collects money from taxpayers who choose to help fund local projects		
User Fees	Charges users an annual or vehicle miles traveled fee to fund roadway improvements		
Private Developers	Charge developers for required improvements to the system as directed by the City Development Code		